

**LOW NO<sub>x</sub> TURBOPOWER® • PACKAGED WATER HEATER  
NICKELSHIELD® NICKEL-PLATED STORAGE TANK  
TANK SERIES 900 GALLONS VERTICAL**

MODEL NUMBER	Recovery gph ①		INPUT Btu/h	Min. Inlet Flow Gas Pressure " W.C. ②	SCAQMD Energy Model No.		Dimensions (inches)		Blower Motor		Shipping Weight #
	40° - 120°F	40° - 140°F			A	B	HP	Amps			
1000 N 900A-TPL	1000	800	800,000	4.5	8TPL	800 MBtu/h	8	1	1/2	7	3170
1500 N 900A-TPL	1500	1200	1,200,000	4.5	12TPL	1200 MBtu/h	8	1-1/4	1	14	3620

① Recoveries based on 83% thermal efficiency. ASHRAE 90.1 compliant for efficiency and standby loss.

② With standard gas train

\* The information presented is for natural gas 0.6 S.G.  
Dimensions are in inches unless otherwise specified.

For standard and optional equipment, see form #PV 6452.

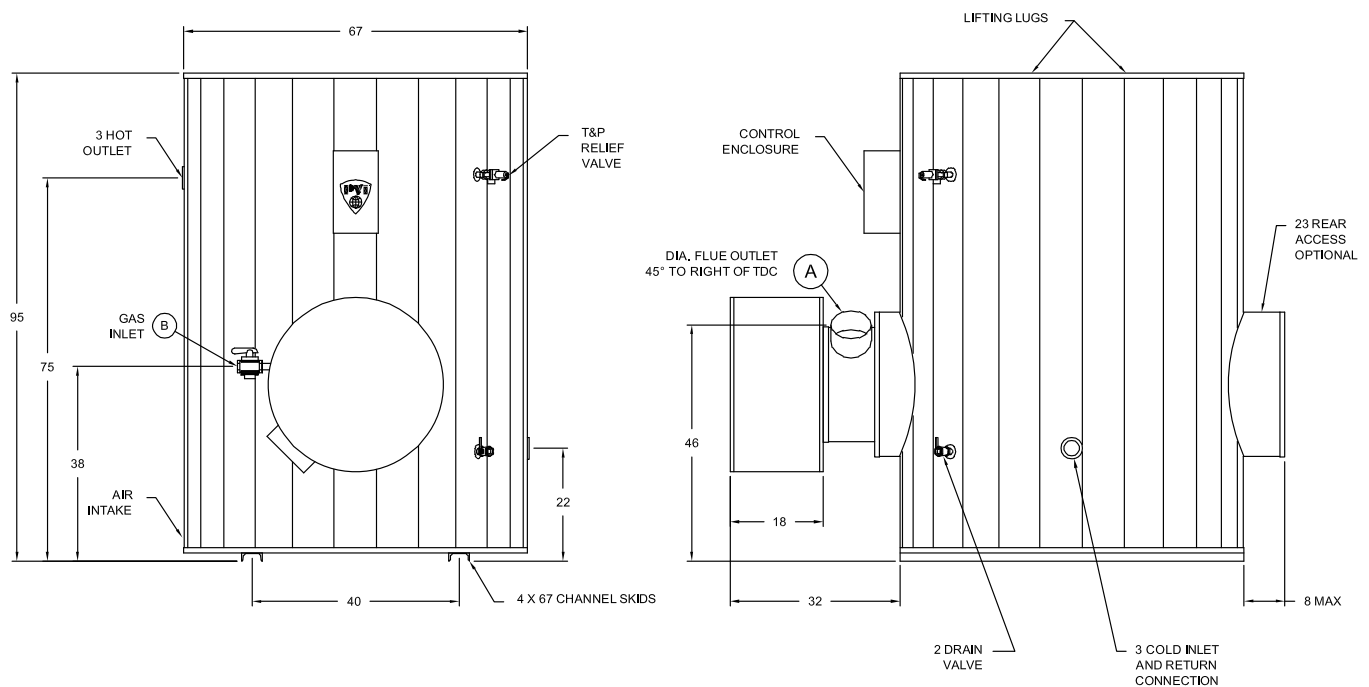

**STANDARD GAS PRESSURE REQUIREMENTS:**  
SEE TABLE FOR MINIMUM PRESSURE BY MODEL.  
MAXIMUM STATIC INLET GAS PRESSURE IS 10.5" W.C.  
FOR GAS PRESSURES OUTSIDE OF THIS RANGE,  
CONTACT YOUR PVI REPRESENTATIVE.

**VENTING REQUIREMENTS:**  
-.02" TO -.06" W.C. (NEGATIVE PRESSURE).  
TYPE B VENTING.  
**ENTIRE VENT SYSTEM SHOULD NEVER BE SIZED BASED UPON  
THE VENT CONNECTION DIAMETER EXCLUSIVELY. CHECK  
NATIONAL FUEL GAS CODE UNDER "FAN ASSISTED."**

**STANDARD ELECTRICAL REQUIREMENTS:**  
**VOLTAGE: 120V, 1Ø, 60 HZ., 20 AMPS.**  
OTHER VOLTAGES REQUIRE AN EXTERNAL  
STEPDOWN TRANSFORMER.

**PVI RESERVES THE RIGHT TO CHANGE THE DESIGN AND  
SPECIFICATION WITHOUT NOTICE.**



PVI INDUSTRIES, LLC  
FORT WORTH, TEXAS 76111  
(800) 784-8326 • www.pvi.com

Product is patented in the U.S., Canada, and Mexico.

PV 6531 06-10

