

# TURBOPOWER® OIL • PACKAGED WATER HEATER

## AquaPLEX® STORAGE TANK (UNLINED DUPLEX ALLOY)

### TANK SERIES 175 GALLONS

Model Number	Recovery gph ①		Input Btu/h	Gph #2 Oil	Max. oil gph (gear capacity) ④	Dimensions (inches)			Blower Motor		Shipping Weight lbs
	40°- 120°F	40°- 140°F				A	B	J ②	HP	Volt/Ph/Amps	
500 L 175A-TPO	500	400	399,000	2.8	70	27	5	17	1/2	115/1Ø/10	1230
750 L 175A-TPO	750	600	600,000	4.3	70	41	6	17	1/2	115/1Ø/10	1310
1000 L 175A-TPO	1000	800	800,000	5.7	70	41	8	17	1/2	115/1Ø/10	1330

① Recoveries based on 83% thermal efficiency. ASHRAE 90.1 compliant for efficiency and standby loss.

② "J" dimension is for the burner housing only.

③ 4" x 37 1/2" Channel skids for inputs ≤ 400 MBtu/h.

4" x 54 1/2" Channel skids for inputs ≥ 600 MBtu/h.

④ Standard gear capacities may change depending on burner supplier.

Designer must use gear capacities from the above chart to size the oil distribution piping system; including transfer pumps (if used).

The information presented is for Natural gas 0.6 S.G.—For operation with Propane (LP gas), consult factory.

Dimensions are in inches unless otherwise specified.

For standard and optional equipment, see form PV 8166.

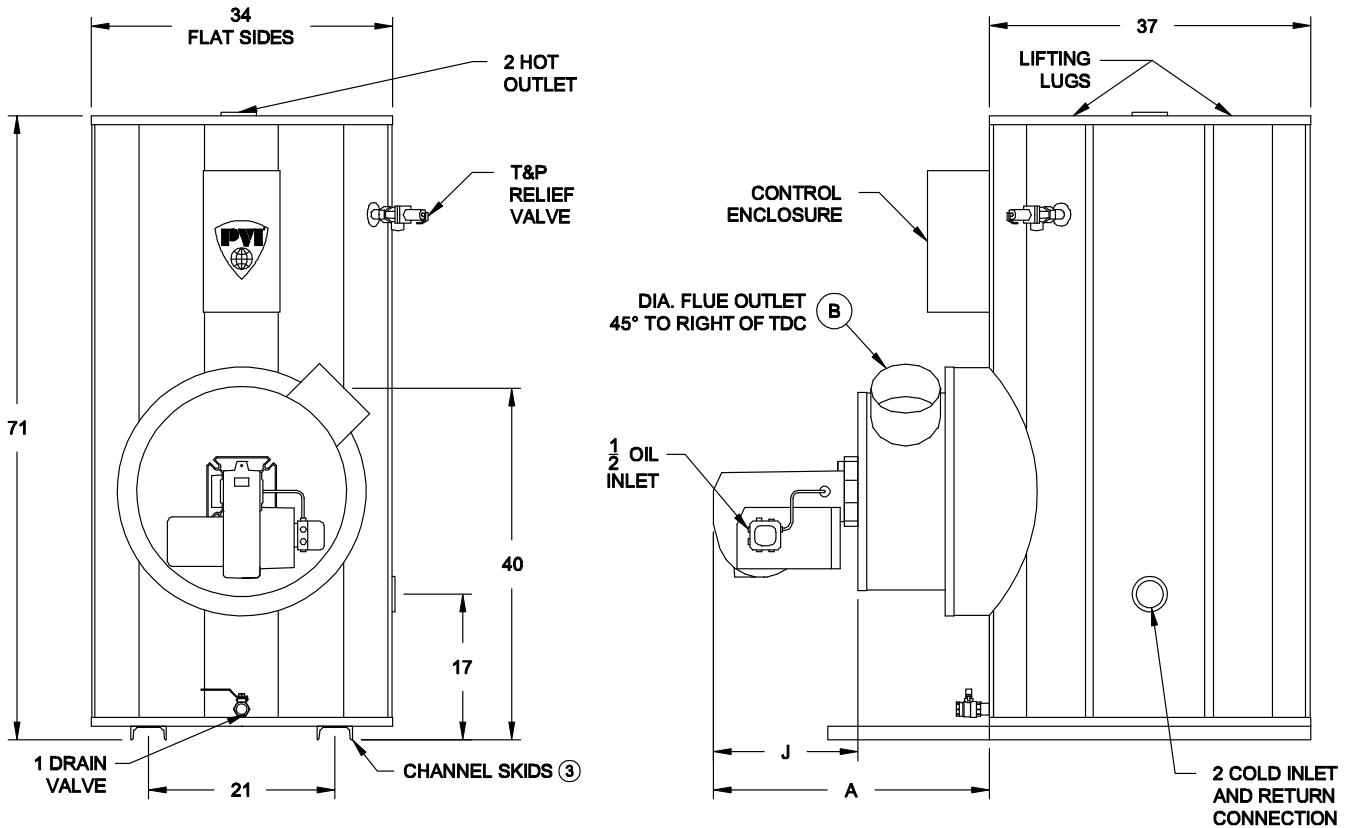

**VENTING REQUIREMENTS**

-.02" TO -.06" W.C. (NEGATIVE PRESSURE)

*ENTIRE VENT SYSTEM SHOULD NEVER BE SIZED BASED UPON THE VENT CONNECTION DIAMETER EXCLUSIVELY. FOR PROPER SIZING, CONSULT VENTING SUPPLIER.*

**STANDARD ELECTRICAL REQUIREMENTS**

CONTROL VOLTAGE: 120V, 1Ø, 60 HZ., 2 AMPS.

MOTOR VOLTAGE:  
208V, 230V, AND 460V MOTORS ARE AVAILABLE BUT WILL REQUIRE A SEPARATE 120V/2 amps CONTROL CIRCUIT OR AN OPTIONAL CONTROL CIRCUIT TRANSFORMER.

**PVI RESERVES THE RIGHT TO CHANGE THE DESIGN AND SPECIFICATION WITHOUT NOTICE.**

