



**POST THESE INSTRUCTIONS
WITH YOUR PRODUCT**

Model No.: _____

Serial No.: _____

GENERAL INSTALLATION AND MAINTENANCE MANUAL

FOR ALL PVI WATER HEATER AND BOILER MODELS

WARNING: If the information on the appliance and in the supplied manual(s) is not followed exactly, a fire, explosion or exposure to hazardous materials may result causing property damage, personal injury or loss of life.

FOR YOUR SAFETY

- Do not store or use gasoline or other flammable vapors and liquids in the vicinity of this or any other appliance.

WHAT TO DO IF YOU SMELL GAS

- Do not try to light any appliance.
- Do not touch any electrical switch; do not use any phone in your building.
- Immediately call your gas supplier from a neighbor's phone. Follow the gas supplier's instructions.
- If you cannot reach your gas supplier, call the fire department.

Installation and service must be performed by a qualified installer, service agency, or the gas supplier.

This product contains, or may come to contain, materials that have been identified as carcinogenic, or possibly carcinogenic, to humans. Before installing, servicing, or removing this product, read and follow the supplied instructions.

WARNING: WATER TEMPERATURES OVER 125°F CAN CAUSE SEVERE BURNS INSTANTLY OR DEATH FROM SCALDS.

PVI INDUSTRIES, LLC
P.O. Box 7124
Fort Worth, TX 76111
(800) 433-5654
www.pvi.com



FEATURES

IMPORTANT:

It is required that a qualified service technician performs the initial firing of the heater. At this time the user should not hesitate to ask the technician any questions that he may have in regard to the operation and maintenance of the unit.

WATER TEMPERATURE CONTROL



DANGER

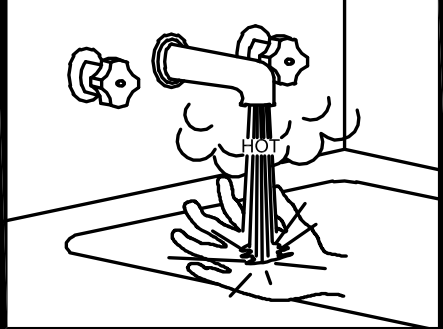

- Water temperature over 125°F can cause severe burns instantly or death from scalds.
- Children, disabled and elderly are at highest risk of being scalded.
- See instruction manual before setting temperature at water heater.
- Feel water before bathing or showering.
- If this appliance is used to produce water that could scald if too hot, such as domestic hot water use, adjust the outlet control (limit) or use temperature limiting valves to obtain a maximum water temperature of 120°F.

WARNING!

This water heater is equipped with an adjustable thermostat to control water temperature. Hot water temperatures required for automatic dishwasher and laundry use could cause scald burns resulting in serious personal injury and/or death. The temperature at which injury occurs varies with the person's age and time of exposure. The slower response time of disabled persons increases the hazards to them. Never allow small children to use a hot water tap or to draw their own bath water. Never leave a child or disabled person unattended in a bathtub or shower. Since the thermostat

temperature setting could be set too high, adjust the thermostat temperature setting to 125°F or lower. Lower settings help reduce risk of scald injury. Remember, no water heater system will provide exact temperature at all times. Allow a few days of operation at this setting to determine the correct temperature setting consistent with your needs and remember, "Hotter water increases the risk of scald injury." Also, the water heater should be located in an area where the general public does not have access to set temperatures.

Table 1 shows the approximate time-to-burn relationship for normal adult skin. Short repeated heating cycles caused by small hot water uses can cause temperatures at the point of use to exceed the thermostat setting by up to 20°F. If you experience this type of use, you should consider using lower temperature settings to reduce scald hazards.

	Temperature Setting	Time to produce 2nd & 3rd Degree burns on adult skin
	180°F	Nearly instantaneous
	170°F	Nearly instantaneous
	160°F	About 1/2 second
	150°F	About 1-1/2 seconds
	140°F	Less than 5 seconds
	130°F	About 30 seconds
	120°F	More than 5 minutes

TABLE 1

IMPORTANT SAFETY NOTE

It takes only 5 seconds of skin contact with 140°F water to cause a second degree burn! You must protect against high water temperatures at all lavatories, tubs, showers and other points of hot water contact.

Accidental scalding from high water temperatures is a greater risk in some types of installations. Some examples are:

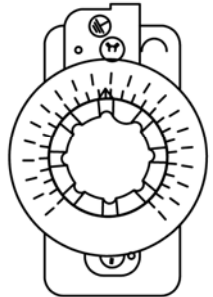
**HOMES FOR THE MENTALLY HANDICAPPED
HOMES FOR THE PHYSICALLY HANDICAPPED
HOSPITALS AND NURSING HOMES
ELDER CARE FACILITIES AND REST HOMES
ORPHANAGES AND CHILD CARE FACILITIES**

OTHER INSTALLATIONS – WHERE RESPONSE TO CONTACT WITH HOT WATER MAY BE SLOWER OR WHERE THE DANGER OF HOT WATER CONTACT IS GREATER

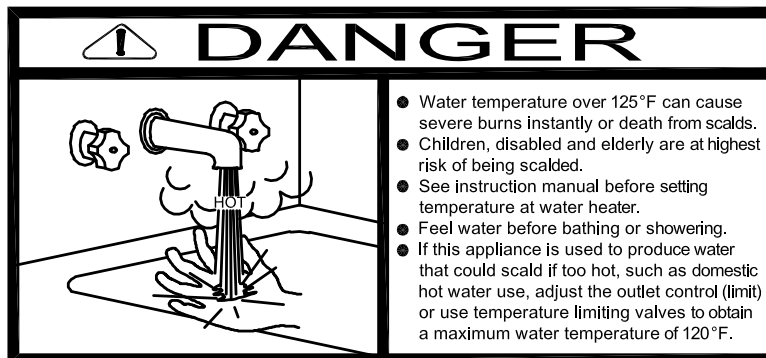

Thermostatically controlled mixing valves must be used in the design of the potable hot water system.

Potable hot water should be tempered to no more than 110°F when used for bathing or other personal use.

Good engineering practice mandates the use of thermostatically controlled mixing valves set at 120°F to keep the delivered water temperature below scalding temperatures.

INTRODUCTION

This manual covers installation, operation and maintenance on all PVI commercial water heaters and storage tanks. Read all instructions thoroughly before attempting to start any unit.

CAUTION: Factory authorized start-up may be required on this equipment. Labeling on the unit will indicate this requirement.

City, state and national codes governing installation of commercial water heaters and storage tanks must be followed and take precedence over recommendations in this manual.

PRODUCT SAFETY INFORMATION REFRACTORY CERAMIC FIBER PRODUCT WITH CRYSTALLINE SILICA

WARNING: This product contains crystalline silica, which has been identified by the International Agency for Research on Cancer (IARC) as carcinogenic to humans. This product also contains refractory ceramic fibers, which have been identified by the IARC as possibly carcinogenic to humans.

Avoid breathing fiber particulates and dust.

RISKS:

- Airborne fibrous insulation is a possible cancer hazard by inhalation.
- Airborne crystalline silica may cause silicosis (lung disease) by inhalation.
- May cause temporary irritation to eyes, skin, and respiratory tract.

PRECAUTIONARY MEASURES:

- Minimize airborne fibers with engineering controls.
- Use NIOSH/MSHA approved respirators as required (see MSDS).
- Wear long sleeved, loose-fitting clothing, eye protection, and gloves.

FIRST AID MEASURES:

- Eyes:** Flush with water.
Skin: Wash with soap and warm water.
Ingestion: Do not induce vomiting. Get medical attention if gastrointestinal symptoms develop.
Inhalation: Remove to fresh clean air.

If any of the above irritations persists, seek medical attention.

WARNING: If you are unfamiliar with the safe handling of Refractory Ceramic Fiber products, or if you wish additional information prior to beginning any disassembly of the water heater or boiler that might expose refractory ceramic fiber materials, contact:

Unifrax Corporation, 2351 Whirlpool Street, Niagara Falls, NY 14305-2413, 1-800-322-2293.

IDENTIFICATION OF REFRACTORY CERAMIC FIBER MATERIALS (The RCF materials are located within the product and not generally exposed except during service, disassembly or assembly.)

- Insulation Insert: TURBOPOWER® water heaters and boilers.
- Flue Collector Insulation: TURBOPOWER® water heaters and boilers.
- Combustion Chamber Insulation and/or Tubesheet Insulation: Atmospheric and Power Gas, VENTURA®, MAXIM™, POWER VT™ water heaters & boilers.

CODES FOR WATER HEATER & BOILER INSTALLATIONS

ANSI Z223.1	National Fuel Gas Code	CGA B149	Installation Code for Gas Burning Appliances & Equipment
ANSI Z83.1	Installation of Gas Piping and Gas Equipment on Industrial and Certain Other Premises	CGA B139	Installation Code for Oil Burning Equipment
NFPA No. 31	Installation of Oil Burning Equipment	National Electrical Code	National Fire Protection Association
ANSI Z95.1	National Fire Protection Association 60 Battery March St., Boston, MA 02210	Canadian Electrical Code	Part 1
NFPA No. 54	Installation of Gas Appliances and Gas Piping	All Provincial Ordinances All State & Local Codes	

PVI WATER HEATERS AND STORAGE TANKS TYPICAL PIPING DIAGRAMS

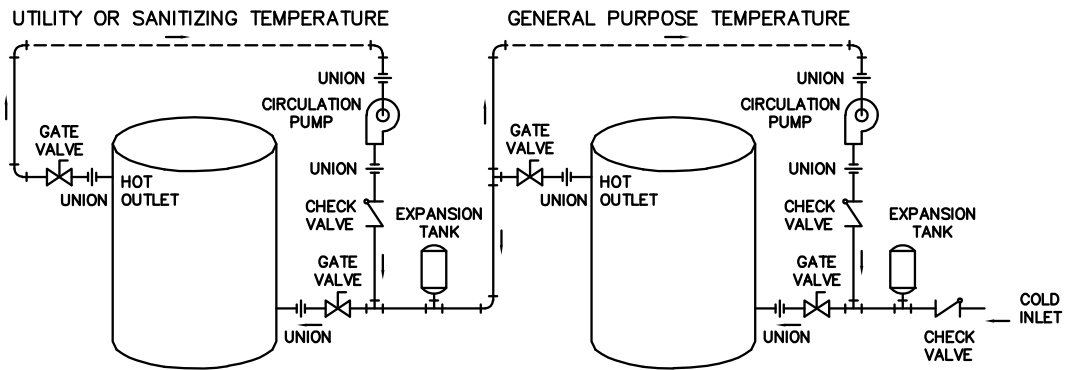

TWO TEMPERATURE SYSTEM
GENERAL PURPOSE AND
UTILITY/SANITIZING TEMPERATURE

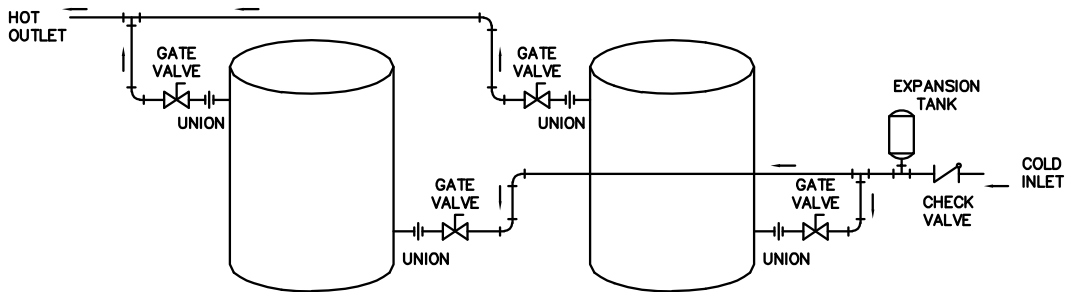

REVERSE DUOFLO MANIFOLD SYSTEM

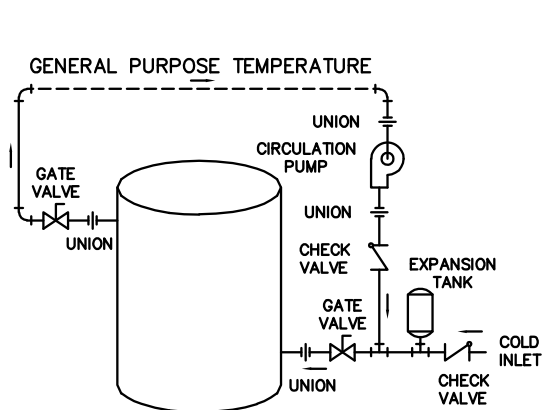

GENERAL PURPOSE
TEMPERATURE SYSTEM

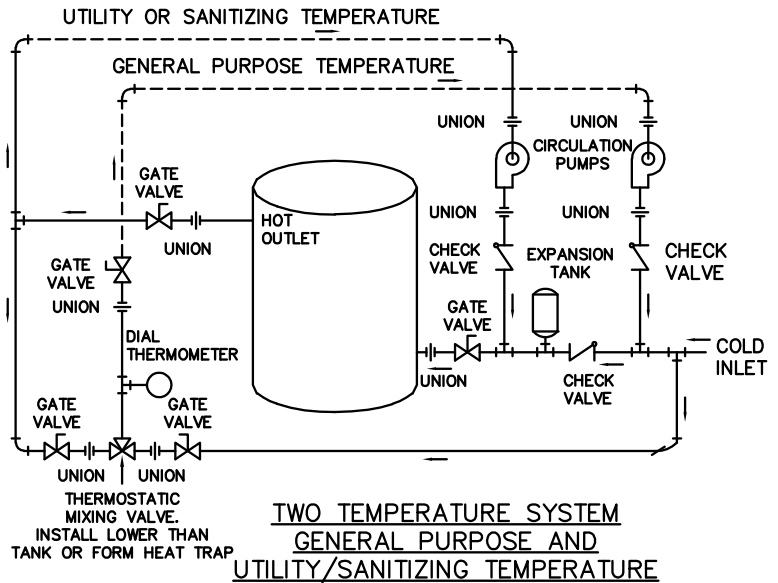

TWO TEMPERATURE SYSTEM
GENERAL PURPOSE AND
UTILITY/SANITIZING TEMPERATURE

FIGURE 1

PVI WATER HEATERS AND STORAGE TANKS

TYPICAL PIPING CONNECTIONS

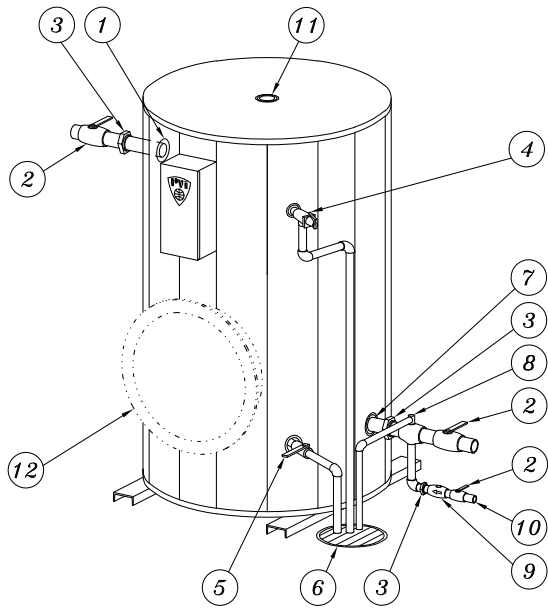

VERTICAL SUPERTANK®

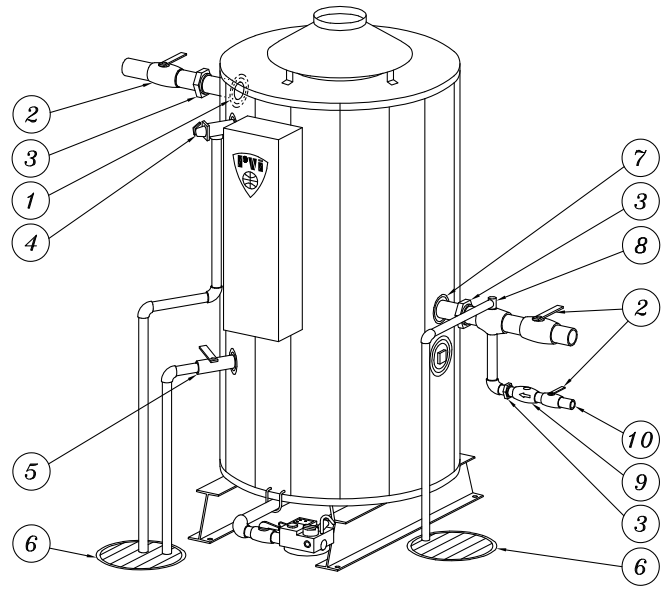

ATMOSPHERIC GAS

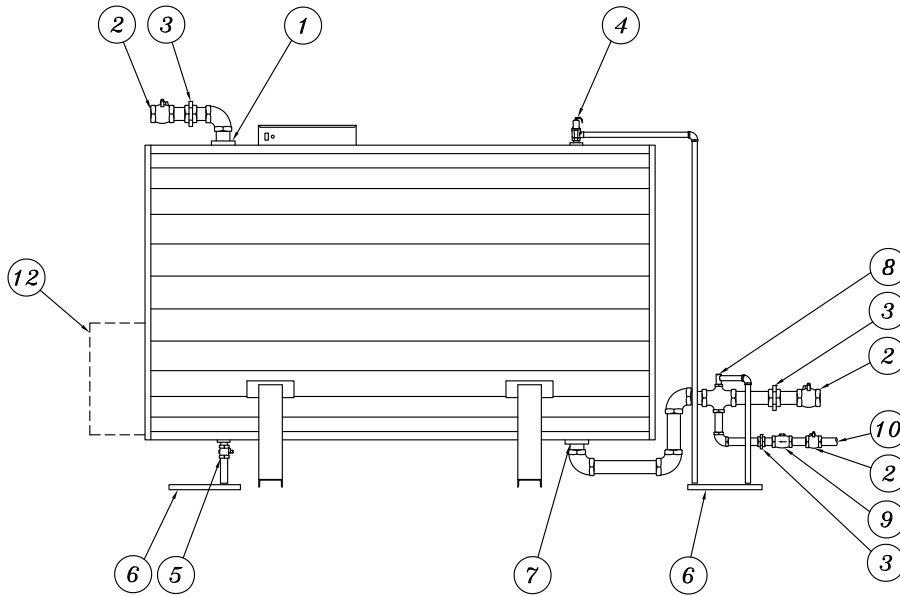

HORIZONTAL SUPERTANK®

- | | |
|--|---|
| <ul style="list-style-type: none"> 1. HOT WATER OUTLET 2. SHUTOFF VALVE <i>(not furnished by PVI)</i> 3. DIELECTRIC UNION <i>(not furnished by PVI)</i> 4. TEMPERATURE AND PRESSURE RELIEF VALVE 5. DRAIN VALVE 6. FLOOR DRAIN <i>(not furnished by PVI)</i> | <ul style="list-style-type: none"> 7. COLD WATER INLET 8. THERMAL EXPANSION CONTROL VALVE <i>(not furnished by PVI)</i> 9. CHECK VALVE <i>(not furnished by PVI)</i> 10. RETURN CIRCULATOR CONNECTION <i>(not furnished by PVI)</i> 11. HOT WATER OUTLET FOR SOME MODELS 12. ENERGY MODULE(S) |
|--|---|

FIGURE 2

VENTING OF GAS & OIL FIRED MODELS

DRAFT REGULATORS POWER GAS OR OIL

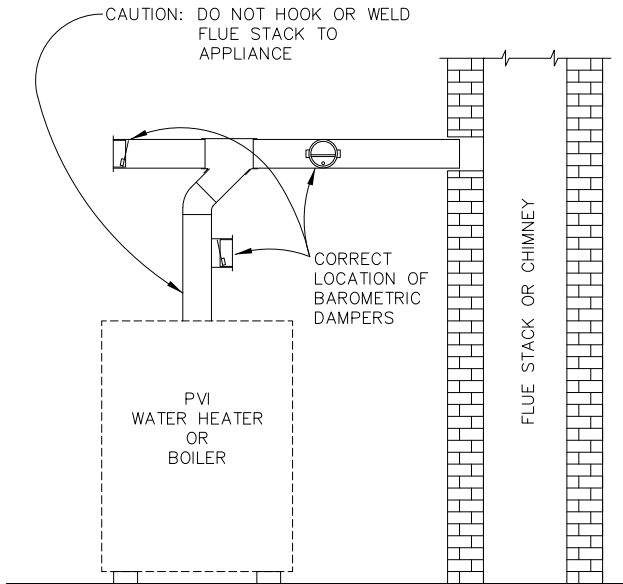

DRAFT REGULATORS DUAL MODULE TURBOPOWER®

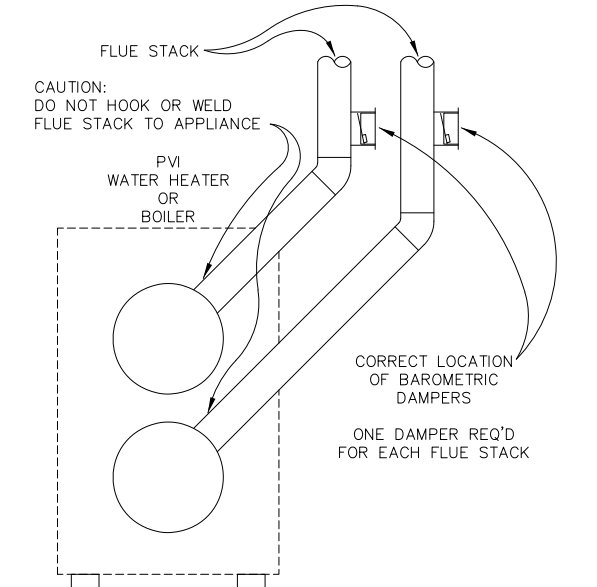

DRAFT REGULATORS SINGLE MODULE TURBOPOWER®

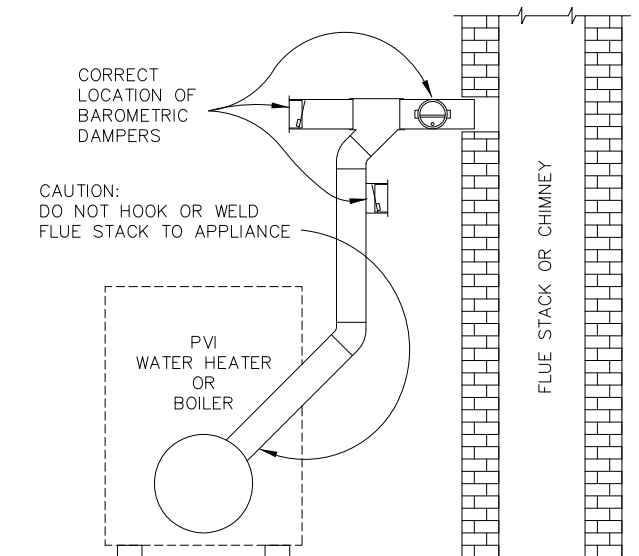

TYPICAL THRU-WALL VENTING

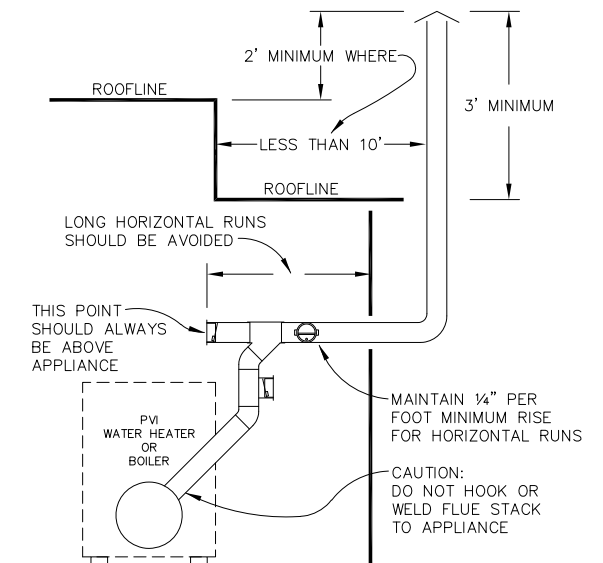

FIGURE 3

LOCATION

1. Locate the unit in a clean and dry area as close as possible to the greatest hot water usage and as near to gas, oil, steam, boiler water and/or electrical power as practical.
2. The unit should be installed on a firm, level foundation.
3. Locate the foundation on a pitched floor near a suitable drain, or make other provisions to prevent contact to areas of the building subject to water damage should the heater or a water connection leak. The drain must be sufficient to contain water in excess of 210°F.
4. Clearances from combustibles and for servicing and inspection are variable depending on model and must be maintained. See product operating instructions for specifications.

INSTALLATION

1. Inspect the water heater and packaged components for damage that may have occurred in shipping and handling or during storage.
2. Check the data decal on the water heater. Be sure the electrical, steam, water, oil, or gas supply is adequate for the installation.

WARNING:

Use caution when moving and rigging these products. To lift or move the water heater, use industry standard safe rigging methods. Failure to follow these instructions could result in property damage, serious injury or death. One common method includes the use of straps and spreader bars, lifting from the water heater base skid assembly.

3. Carefully remove all shipping supports and bracing. (Float type devices have shipping plugs blocking the float).
4. Connections to the cold water inlet and hot water outlet should be installed with shut-off valves and unions so that the unit may be disconnected for servicing. Use caution when threading pipe nipples into tank connections to prevent cross threading, or over-tightening. Always use a back-up wrench on tank nipples when tightening unions, valves, etc.

IMPORTANT:

Do not use standard galvanized or steel pipe nipples when making connections to the tank. Use non-ferrous or dielectric nipples only.

5. Some tank fittings will be attached to the tank wall with studs. Check these type fittings for leaks after filling tank. Do not over-tighten the studded connections as damage to the o-ring under the fittings may occur. A maximum torque of (15) ft. lbs.

(unlubricated) should be used on studded connections - tighten only in alternating pattern.

6. Hot water and return circulation lines should be insulated. Cold water supply lines should be insulated if subject to freezing during shutdown periods.
7. A thermal expansion valve (or diaphragm-type expansion tank) should be installed in the cold water line between the water heater and any check valve (see Figure 2).

IMPORTANT:

Do not use the plumbing connected to the appliance as a ground for welding or any other purpose.

8. The water heater is equipped with a temperature and pressure relief valve(s) rated for the input of the energy source and the working pressure of the tank. The relief valve discharge should be piped to a suitable open drain. The drainpipe may not be smaller than the relief valve opening and must be secured to prevent it from lifting out of the drain under discharge pressure. Do not install valves or restrictions in the discharge line. Storage tanks must have over pressure protection. If not factory installed, a properly rated temperature and/or pressure relief valve must be installed in the fitting furnished for that purpose (see Figure 2).
9. The drain valve should be piped to a suitable open drain.

ELECTRICAL

This product uses 120 volts for control power and must be electrically grounded in accordance with local codes, or in the absence of local codes, with the latest edition of the National Electrical Code ANSI/NFPA. When unit is installed in Canada, it must conform to the CSA C22.1, Canadian Electrical Code, Part 1 and/or local electrical codes.

CAUTION:

Use only copper wire of proper sizing for incoming service. Damage resulting from use of aluminum wiring will be excluded from coverage under the warranty of this unit.

1. Branch circuit protection and disconnecting means must be furnished by the installer. Refer to the wiring diagram provided with this unit when installing or troubleshooting the electrical components of this heater.
2. All wiring must be in accordance with all local, state, or federal codes.
3. Provide proper overload protection for the system's circulating pump.

COMBUSTION & VENTILATION AIR OPENING

Provisions for combustion and ventilation air must be in accordance with Section 5.3, Air for Combustion and Ventilation, of the latest edition of the National Fuel Gas Code ANSI Z223.1, or applicable provisions of the local building codes.

The equipment room must be provided with two openings to assure adequate combustion air and proper ventilation.

1. If air is taken directly from outside the building (see Figure 4):
 - a. Inlet air opening, 1 square inch per 2,000 Btu/h input. This opening must be located near the floor.
 - b. Outlet air opening, 1 square inch per 2,000 Btu/h input. This opening must be located near the ceiling.
2. If air is taken from another interior space (see Figure 5), each opening specified above should have a minimum free area of 1 square inch per 1,000 Btu/h input.

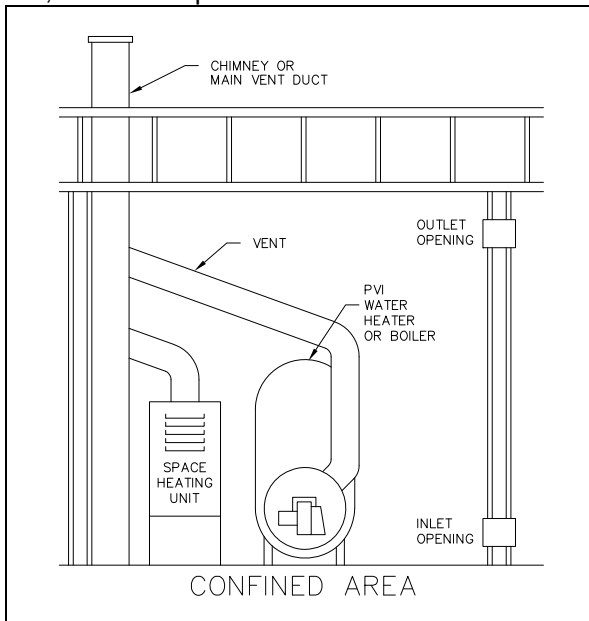

FIGURE 4 - Equipment located in confined spaces; all air from outdoors

CAUTION:

Under no circumstances should the equipment room ever be under negative pressure. Particular care should be taken when exhaust fans, compressors, air handling units, etc. may rob air from combustion equipment.

The combustion air supply must be completely free of any chemical fumes. Common chemicals that must be avoided are

fluorocarbons and other halogenated compounds most commonly present as refrigerants or solvents such as freons, trichlorethylene, perchlorethylene, chlorine, or salts for use in water softeners or any other heavy gas are particularly injurious and corrosive after contact with flames or hot surfaces. The result is improper combustion and premature equipment failure.

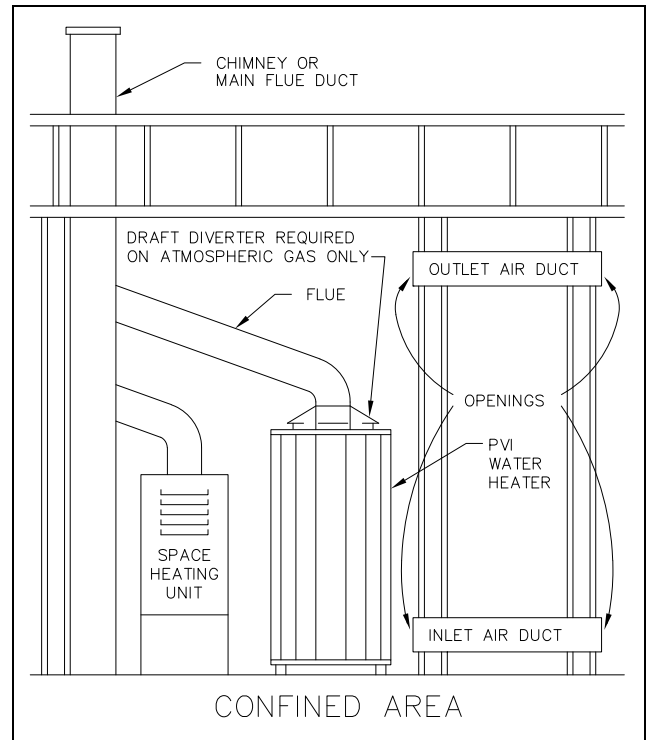

FIGURE 5 - Equipment located in confined spaces; all air from inside the building.

VENTING

CAUTION:

Never size a flue vent based only on the flue outlet size of the product.

Vent installations for connection to gas vents or chimneys must be in accordance with Part 7, Venting of Equipment, of the latest edition of the National Fuel Gas Code, ANSI Z223.1, or applicable provisions of the building codes.

1. A flue vent passing through the roof must be terminated in accordance with Section 7.6.2, Gas Vent Termination, of the latest edition of the National Fuel Gas Code, ANSI Z223.1, or applicable provisions of the local building codes.
2. A gas vent passing through a wall must be terminated in accordance with Section 7.8, Through the Wall Vent Termination, of the latest edition of the National Fuel Gas Code, ANSI Z223.1, or applicable provisions of the local building codes.

WARNING:

Vent connectors serving appliances vented by natural draft shall not be connected into any portion of mechanical draft systems operating under positive pressure. Failure to observe this warning could result in property damage, serious injury or death.

- The vent connector must be the same size as the product flue outlet. The vent size must be determined by the BTU input of the product(s) and the vent design. The horizontal breeching of a vent must have at least 1/4" rise per linear foot not to exceed the length of horizontal vent.

CAUTION:

Do not weld or support breaching to product flue outlet. Adequate support of the venting system must be provided in compliance with local or other applicable codes.

- Draft regulators (barometric dampers) may be incorporated in the vent for gas, oil, and gas/oil fan assisted products and are recommended. A single swing barometric damper should be used for oil-fired products. The double swing type should be used on gas or gas/oil fired products. Under normal venting conditions, the draft regulator should be the same size as the flue outlet of the product, never smaller. Draft regulators must be installed and adjusted in accordance with the manufacturer's instructions (see Figure 3).

IMPORTANT:

A minimum of -.02" to -.06" W.C. draft is required for appliances vented by natural draft.

GAS PIPING

- Before making gas hook-up, verify that the unit is being supplied with same gas type as indicated on the data decal.
- The maximum inlet gas pressure must not exceed the value specified. If delivery pressure is higher, a single suitable intermediate, lock-up type regulator must be installed ahead of the low-pressure regulator on the burner to reduce inlet pressure to acceptable limits. The regulator must have a flow regulating capacity suitable for the firing rate.
- The gas supply line must be of sufficient size for length of run and pressure drop to furnish adequate gas pressure to allow the burner to develop its rated capacity. A drip leg should be installed ahead of burner piping connection, if not supplied (See Table 2).
- Gas valves and gas regulators may contain bleed or vent ports. Local codes may require bleeds

and vents to be vented to atmosphere outside the

building. Consult local building codes for size and installation.

Equivalent feet from meter	PIPE SIZE					
	Maximum Capacity for Natural Gas*					
	MBTU/HR Based on 0.5" W.C. Pressure Drop*					
	1-1/4"	1-1/2"	2"	2½"	3"	4"
25	860	1320	2475	3900	7000	-
40	660	990	1900	3000	5300	-
60	-	810	1520	2400	4300	-
80	-	690	1300	2050	3700	-
100	-	620	1150	1850	3250	6700
125	-	-	1020	1650	2950	6000
150	-	-	950	1500	2650	5500
175	-	-	850	1370	2450	5000
200	-	-	800	1280	2280	4600

TABLE 2

*Multiplier for Propane: 1.57

**Multiplier for alternate pressure drops: 0.3" W.C. 0.77; 1.0" W.C. 1.41; 2.0" W.C. 2.00; and 4.0" W.C. 2.82.

CAUTION:

Be sure gas supply and vent lines have been cleaned of all debris, which could enter the regulators or burner system and cause malfunction or unsafe conditions. Pipe joint sealant should be used instead of tape and should be resistant to liquefied petroleum when LP gas is used.

OIL TANK AND SUPPLY LINES FOR OIL AND COMBINATION GAS/OIL WATER HEATERS

- The oil tank construction and installation must meet local codes and should meet the specifications recommended by Underwriter's Laboratories (see Figure 6).

IMPORTANT:

The combination gas/oil burner requires a constant supply of fuel oil for pump lubrication, even when running on gas. Make sure the oil shutoff valve is open and oil is available at the pump when the burner is in service. If no oil supply is available and burner must be run on gas, remove the oil pump coupling on burner.

A two-pipe system must be used at the burner inlet. A single pipe system may be used to supply local holding tanks at individual burners (up to 50 gallons, or check your local codes), but provisions must be made for a return line from the burner oil pump to the holding tank. When a gravity feed system is used install anti-siphon valve close to tank in supply line.

- Oil supply and return lines must be installed below frost level. Below-floor-level runs are preferred inside the building. Avoid overhead runs, which can cause excess lift for the oil pump. Return lines must be as large as the supply lines with no shutoff valves in the line. If a shutoff valve is installed in existing return line piping, remove or open and disable it to prevent accidental closure.

IMPORTANT:

A supply line filter must be installed and cleaned or replaced regularly.

- 90% of all oil pump problems resulting in poor cutoff, noisy operation and erratic firing are caused by air vacuum leaks in the supply (suction) line. To avoid air leaks, both return and supply lines should extend to near bottom of the oil tank. Only flare type fittings should be used, and all fittings and joints must be tight. Check and recheck all fittings and joints for air vacuum leaks.

- Supply line size is based on the suction developed from the total "gear capacity" of the pump. The pump is a positive displacement type and pumps a constant volume of oil, only a portion of which is used by the nozzle(s), the remainder being bypassed to the return line. During gas operation on the combination gas/oil burner, the pump is operational, but all oil is bypassed to the return line.

- No allowance has been made in the recommended supply lines sizes (see Table 3) for additional severe restrictions such as multiple elbows, etc. If in doubt of the size required, use the next size larger than recommended. The oil lines (especially the supply line) must be absolutely leak tight to prevent loss of prime. Do not use Teflon tape or oil soluble pipe dope.

CAUTION:

If the "lift" from the oil tank to the pump inlet is over 12 feet or if the "lift" plus the supply line pressure drop is such that the total suction at the pump exceeds 15" mercury, install a booster pump. Pressure at the burner inlet must not exceed 3 psi.

RECOMMENDED OIL SUPPLY & RETURN LINES						
LIFT ABOVE TANK	COPPER TUBING SIZE (OD)			IRON PIPE SIZE		
	LENGTH OF RUN			LENGTH OF RUN		
	50'	100'	200'	50'	100'	200'
0 feet	1/2"	1/2"	5/8"	3/8"	3/8"	1/2"
5 feet	1/2"	1/2"	5/8"	3/8"	3/8"	1/2"
8 feet	1/2"	1/2"	5/8"	3/8"	3/8"	1/2"
12 feet	1/2"	5/8"	5/8"	3/8"	1/2"	1/2"

TABLE 3

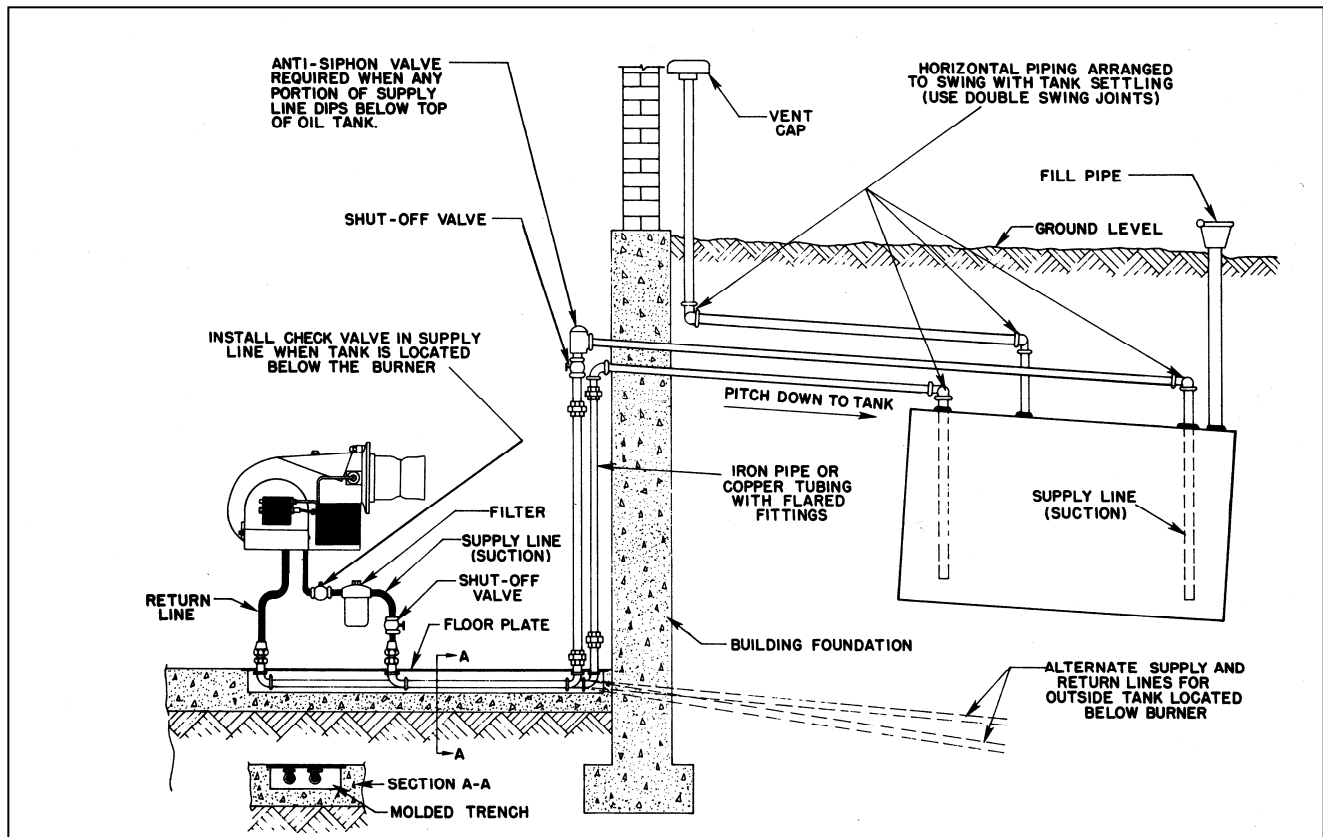

FIGURE 6

SUPERTANK™ BOLTED HEAD REMOVAL

SUPERTANK™ water heaters and storage tanks will have one or more removable heads or bolted tank sections. The heads may be used for mounting an energy module (i.e. TURBOPOWER® module, electric elements, QUICKDRAW® or QUICKSTORE® steam or water heat exchanger heating elements) or bolted head for access to the tank. If a head or module is removed during the course of maintenance, replace the O-ring and all special high quality 9/16"-12 NC, grade 8 bolts, washers and nuts with identical parts available from your PVI representative or directly from PVI. Do not reuse or substitute these special fasteners with similar grade 8 bolts, washers and nuts. Install the flange bolts and nuts with a flat washer under each bolt head and nut. First, snug them in an alternating star pattern. Then,

using a calibrated torque wrench, and in an alternating star pattern, tighten the bolts in 2 increments: 95 ft lbs and 145 ft lbs. Use a small amount of silicone RTV to hold the o-ring in place while positioning the flanged head or heat exchanger. Apply adhesive sparingly!

Contact PVI at 1-800-433-5654 for replacement Fastener Kits and O-Ring Replacement Instructions.

IMPORTANT

Mark one hole on head and on tank flange for reference when removing head. Be certain to align these holes during reassembly to insure the original gasket or O-ring mating surfaces will be correctly positioned.

TYPICAL VERTICAL SUPERTANK® BOLTED HEAD ATTACHMENT

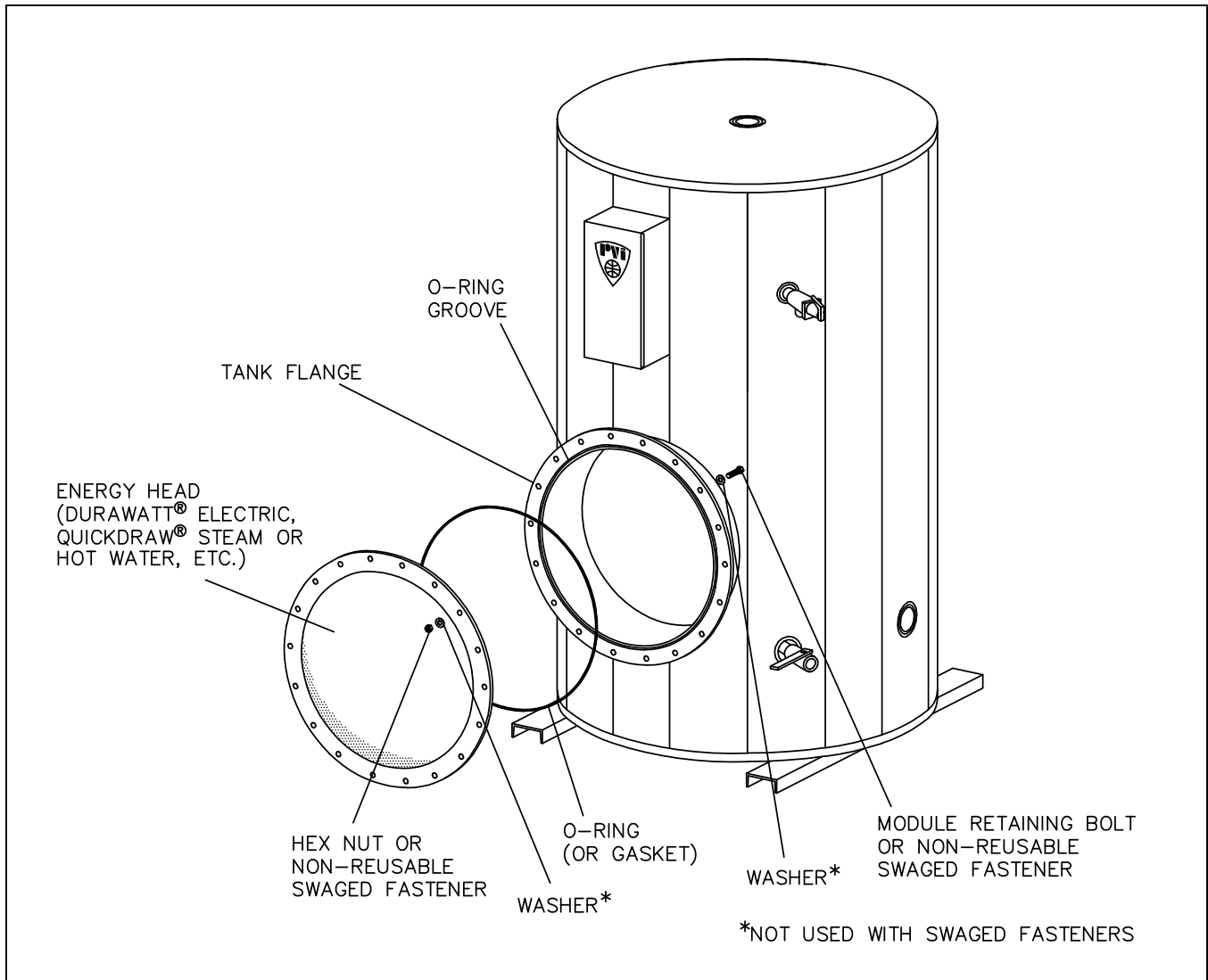

FIGURE 7