

INSTALLATION & MAINTENANCE MANUAL FOR
PVI FIREPOWER[®]
B40 OIL BURNER
1.0 thru 10.0 gph

CARBON MONOXIDE WARNING:
CAUTION: IMPROPER COMBUSTION MAY CAUSE SERIOUS INJURY.
PVI recommends a seasonal or annual combustion check-out be performed by a
qualified service agency to ensure safe and efficient operation.

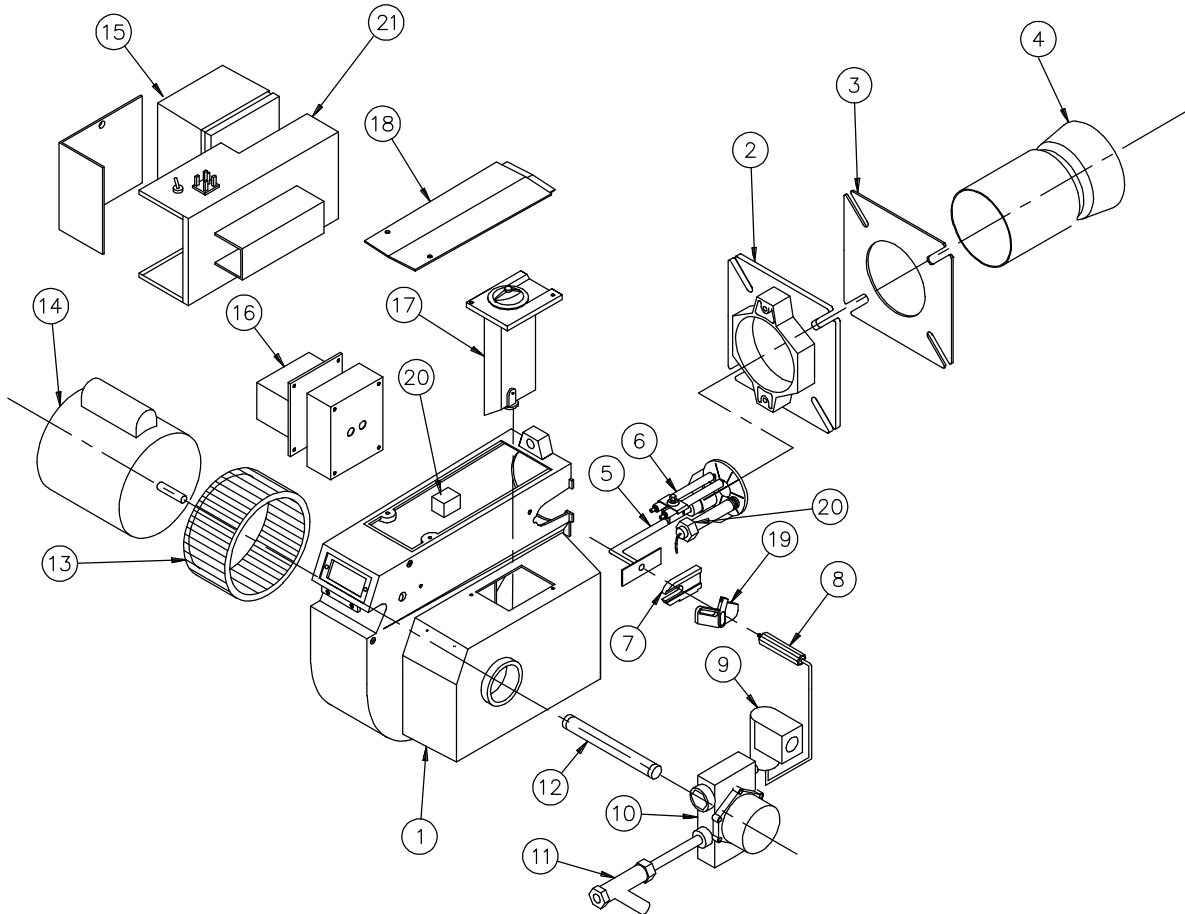

Typical Construction
Figure 22A-1

- | | | | |
|-----|---------------------|-----|----------------------|
| 1. | Burner housing | 12. | Pump coupling |
| 2. | Mounting flange | 13. | Fan wheel |
| 3. | Flange gasket | 14. | Fan motor |
| 4. | Blast tube | 15. | Flame safeguard |
| 5. | Oil nozzle assembly | 16. | Ignition transformer |
| 6. | Ignition electrodes | 17. | Damper assembly |
| 7. | Housing plug | 18. | Housing cover |
| 8. | Connecting pipe | 19. | Locating block |
| 9. | Electric oil valve | 20. | Scanner or photocell |
| 10. | Oil pump | 21. | Control enclosure |
| 11. | Oil strainer | | |

PVI FIREPOWER[®]
B40 OIL BURNER

FOR YOUR SAFETY

DO NOT store or use gasoline or other flammable vapors and liquids in the vicinity of this or any other appliance.

FOR YOUR SAFETY

WARNING: Improper installation, adjustment, alteration, service or maintenance can cause injury or property damage. Refer to this manual for assistance, or consult a qualified service agency.

ELECTRICAL

1. Wiring to the unit should conform to the National Electrical Code or the code legally authorized to your locality. A fused disconnect switch should be used for water heater control. Service wiring connections of 115V, 1 phase, 60 Hz. are located in the enclosure on the water heater. (See Figure 22-10, pg. 14.)

NOTE: Use only copper wire of proper sizing for incoming service. Damage resulting from use of aluminum wiring will be excluded from coverage under the warranty of this unit.

PVI FIREPOWER[®]

B40 OIL BURNER START-UP

(Refer to Figure 22-1 to identify burner parts)

1. Remove the enclosure panel cover on the water heater or boiler to expose the control circuit. The wiring diagram, located on the backside of the cover, will show the controls used in our circuitry.
2. Visually check that all components are intact and no damage has occurred during transit.
3. Check all connections in control cabinet. A loose connection could cause intermittent shutdowns.
4. Check oil supply lines to insure proper practices have been followed and installation complies with local codes. Use only a two-pipe system. Check for adequate burner intake air supply.
10. Tighten the electrode mounting clamp slightly until electrode ceramics are seated firmly and completely in the mounting bracket without gaps between ceramics and mounting bracket at the bearing faces.

NOTE: Do not tamper with or readjust program dipswitch settings. This will cause the control to become inoperable. Damage resulting from tampering will be excluded from coverage under the warranty of this unit.

5. Remove the flame safeguard control from its base. Check the connections in control mounting base; loose connections can cause nuisance shutdowns. When applicable, check the time card or programmer, for good connection.
6. With electrodes exposed, check them for the proper settings as in Figure 22-4 & 7, pages 7 & 8. Check for any hairline cracks in the insulators. Should replacement of burner electrodes be required, certain procedures must be followed. In all cases, removal of electrodes is accomplished by loosening the electrode mounting clamps. Draw electrodes out of the nozzle assembly through the holes in the pressure plate.
7. Open manual oil valve(s). Make certain check valves are positioned for the correct oil flow. There should not be a manual shut-off valve in the return line from the pump to the tank.
8. Pull the nozzle assembly to check the ignition electrodes. See Figure 22-3 & 6, pages 7 & 8.
9. Inspect the electrodes for cracked ceramic or loose retaining studs that hold the wire within the ceramic. Select the proper pressure plate hole to place each electrode and insert the electrode through the hole, retaining stud end first.
11. Measure and set electrodes according to Figure 22-4 & 7, pages 7 & 8. After gaps and setting are complete, fully tighten electrode mounting clamp. **Do not overtighten or insulation may crack.**
12. Replace nozzle assembly; be sure to connect the spark rod wires before installing nozzle assembly fully into blast tube. Check connections on the ends of the flame and spark rod wires for good contact. Look for properly stripped wire ends. Be sure connectors are firmly attached to the ignition rod ends. Insulating boots can give a false feeling of proper seating. **DO NOT MOVE ELECTRODES.** Be careful not to bump electrodes. Check fan wheel for free rotation.
13. Connect a test meter to the control for reading the flame response signal.

NOTE: Some controls read the flame signal in micro amps and some in volts DC. The MC120 series control has two terminals marked for reading volts DC.

14. Be sure tank is filled with water. Once the burner is reassembled, a gauge to read pressure, preferably a 300 psi gauge, will be needed to read oil pressures. Connect gauge to the pressure side of the oil pump. Connect vacuum gauge to supply side of oil pump (15" HG maximum allowed).
15. **Single stage oil burners.** Before turning the unit on, make sure all valves in the oil supply and return lines are on. Check the air damper setting against the setup tag attached to the burner. Turn the unit on using the rocker switch on the side of the control cabinet. If the operating control switches are closed, the burner blower should come on and prepurge begins.

If nothing happens, check the control to be sure it is not in the tripped position and reset it by pushing the flame safeguard reset button. Burner should prepurge for no more than thirty seconds.

PVI FIREPOWER[®]

B40 OIL BURNER START-UP (con't)

After purging is complete, terminal 3 energizes the oil valve and terminal 4 energizes the ignition transformer. The flame is then established and the VDC reading on the meter should read a steady 14-18 VDC for photocell or 4-6 VDC for UV amplifiers. Each different control will have the required flame response signal stamped on it. This is the minimum for it to properly operate. If the burner fails to light during the initial period, it is probably due to air in the line. The control will lock out. Push the flame safeguard reset button to restart burner and begin the purge cycle again.

Once the flame is established, set the oil pressure (measured at the oil pump) at the pressure shown on the tag attached to the burner. Oil pressure should be adjusted while firing on the second stage. Do not exceed the oil supply pressure specified on the setup tag.

16. **Two stage oil burners.** Before turning the unit on, make sure all valves in the oil supply and return lines are on. Check the first stage air damper setting against the setup tag attached to the burner. The second stage air setting must be adjusted while the burner is operating. Turn the unit on using the rocker switch on the side of the control cabinet. If the operating control switches are closed, the burner blower should come on and prepurge begin.

If nothing happens, check the control to be sure it is not in the tripped position and reset it by pushing the flame safeguard reset button. The burner should prepurge for no longer than thirty seconds.

After purging is complete, terminal 3 energizes the oil valve and terminal 4 energizes the ignition transformer. The flame is then established and terminal 5 energizes the main oil valve after a short delay. This will simultaneously supply oil to the second stage oil nozzle and the damper actuator, driving the damper open. The burner can be temporarily locked in the first or second stage by adjusting the low-fire hold switch. The VDC reading on the meter should read a steady 14-18 VDC for photocell or 4-6 VDC for UV amplifiers. Each different control will have the required (minimum) flame response signal stamped on it. If the burner fails to light during the initial period, check for air in the line. The control will lock out. Push flame safeguard reset button to restart burner and begin purge cycle again.

Once the flame is established, set the oil pressure (measured at the oil pump) at pressure shown on the tag attached to the burner. Oil pressure should be adjusted while firing on the second stage. Do not exceed the oil supply pressure specified on the setup tag.

17. Check flue gases with a flue analyzer and smoke spot pump to make final settings of the air damper.
- Readings need to be taken from a hole in the vent several inches from flue outlet connection.
 - Insert draft gauge into the test opening in the stack. Draft in stack should read $-.02''$ to $-.06''$ W.C. Adjust draft regulator, if installed.
 - Insert analyzer in test opening and determine O_2 content in percentage.
 - Gradually close air damper to decrease O_2 reading or open air damper to increase O_2 reading until optimum O_2 % (4-5%) is reached. Refer to Figure 22-2 & 5, pages 7 & 8 for damper adjustment details.
 - Once the O_2 reading is in the specified range, check smoke content in the flue gas by pumping ten times through a new smoke spot sample paper. Smoke spot should not exceed a #2. If the smoke spot exceeds a #2, it may be necessary to increase the O_2 %.
 - Once combustion is set, take note of the gross stack temperature; maximum gross stack is to be $400^\circ F$, minimum net stack is to be $300^\circ F$. **(NOTE: net temperature is the total stack temperature, less room temperature.)** If an excessively high gross stack temperature is recorded, consult the factory.
 - Make sure air shutter is locked securely in place.
18. On two-stage oil burners, the preceding analysis must be done for the first and second stage.
19. Check each operating and limit control to be sure they function properly by lowering and raising the temperature setting on each of the controls, causing the burner to cycle on and off.

PVI FIREPOWER[®]

B SERIES OIL BURNER START-UP (con't)

20. Record the following information for future use:

- | | |
|--|---------------------------------|
| a) Air shutter position _____ | g) Smoke _____(less than #2) |
| b) Oil supply pressure _____PSIG | h) Stack temperature: |
| c) Stack draft _____" W.C. | Gross _____°F. |
| d) O ₂ reading _____% (4-6%) | Less ambient _____°F. |
| e) CO ₂ reading _____% (10-12%) | Net _____°F. |
| f) CO reading _____ ppm (less than 300) | i) Combustion efficiency _____% |

NOZZLE RATING gph GPH 100 PSI	OPERATING PRESSURE: IN POUNDS PER SQUARE INCH						NOZZLE RATING gph GPH 100 PSI	OPERATING PRESSURE: IN POUNDS PER SQUARE INCH					
	85	100	125	150	175	200		85	100	125	150	175	200
.40	.36	.40	.45	.49	.53	.56	3.00	2.76	3.00	3.35	3.68	3.97	4.25
.50	.46	.50	.56	.61	.66	.71	3.75	3.45	3.75	4.19	4.59	4.96	5.30
.55	.50	.55	.61	.67	.72	.77	4.50	4.14	4.50	5.04	5.51	5.95	6.36
.60	.55	.60	.67	.74	.79	.85	5.00	4.60	5.00	5.59	6.13	6.61	7.07
.65	.59	.65	.73	.80	.86	.92	5.50	5.07	5.50	6.15	6.74	7.27	7.78
.75	.69	.75	.84	.92	.99	1.06	6.00	5.53	6.00	6.71	7.33	7.94	8.48
.85	.78	.85	.95	1.04	1.13	1.20	6.50	5.99	6.50	7.26	7.96	8.60	9.20
1.00	.92	1.00	1.12	1.23	1.32	1.41	7.50	6.91	7.50	8.38	9.19	9.91	10.60
1.10	1.01	1.10	1.23	1.34	1.45	1.55	8.50	7.83	8.50	9.50	10.41	11.24	12.02
1.25	1.15	1.25	1.39	1.53	1.65	1.76	10.00	9.21	10.00	11.18	12.24	13.22	14.14
1.35	1.24	1.35	1.51	1.65	1.78	1.91	11.00	10.14	11.00	12.29	13.47	14.55	15.55
1.50	1.38	1.50	1.68	1.84	1.98	2.12	12.00	11.06	12.00	13.40	14.70	15.90	17.00
1.75	1.61	1.75	1.96	2.14	2.32	2.48	13.50	12.44	13.50	15.09	16.53	17.85	19.09
2.00	1.84	2.00	2.24	2.45	2.65	2.83	15.00	13.82	15.00	16.77	18.37	19.84	21.21
2.25	2.07	2.25	2.52	2.74	2.98	3.18	17.00	15.67	17.00	19.00	20.82	22.48	24.04
2.50	2.30	2.50	2.80	3.06	3.30	3.54	19.50	17.97	19.50	21.80	23.90	25.80	27.60
2.80	2.58	2.80	3.13	3.42	3.70	3.95	22.00	20.28	22.00	24.59	26.94	29.10	31.11

TABLE 22-1

PVI FIREPOWER[®]

SINGLE STAGE B SERIES OIL BURNER ADJUSTMENTS

AIR ADJUSTMENT

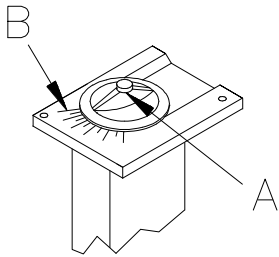

Loosen the locking screw and move the knob (A) along the scale (B) to the position wanted and tighten the screw. Check the air adjustment by making a flue gas analysis.

Figure 22A-2

ADJUSTMENT & REMOVAL OF NOZZLE ASSEMBLY

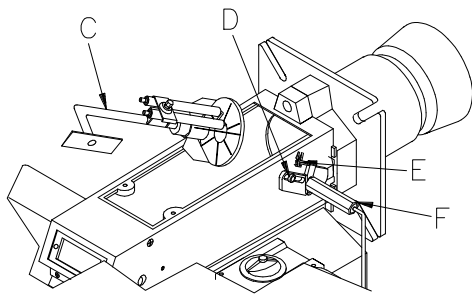

To adjust nozzle assembly (C), loosen screw (D) and move the nozzle forward or retract by turning the adjustment screw (E). Line up the pointer on the locating block to the index position specified in Table 22-2 (pg. 9) for best results.

To remove the nozzle, remove the burner cover and disconnect the electrode cables. Separate the nozzle assembly from the fan housing by loosening the connecting pipe (F) and extracting the connecting pipe from the nozzle port.

Figure 22A-3

IGNITION ELECTRODE ADJUSTMENT

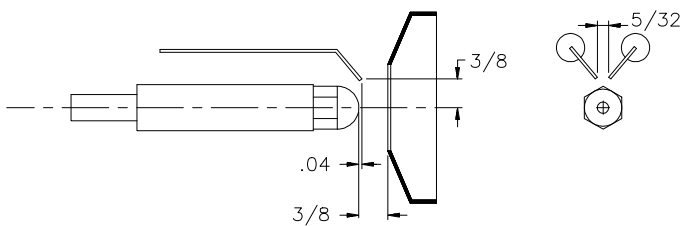

Check that the measurements between the nozzle, the ignition electrodes and the pressure plate correspond to Figure 22-4.

Figure 22A-4

PVI FIREPOWER[®]

TWO STAGE B SERIES OIL BURNER ADJUSTMENTS

AIR ADJUSTMENT

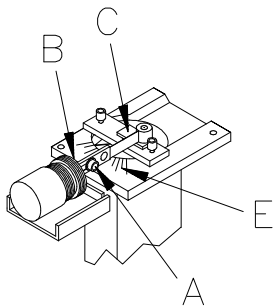

First stage: Set the operating switch on low capacity. Loosen the screw (A) and move the damper arm (C) along the scale (E) to a position where the flame does not soot nor blow out. Tighten the screw.

Second stage: The operating switch remains on low capacity. Screw the knurled ring (B) by means of an adjustment pin in (reduce) or out (increase). The position of the damper can be read on the damper scale (E).

Check the air adjustments of the second stage by making a flue gas analysis.

Figure 22A-5

ADJUSTMENT & REMOVAL OF NOZZLE ASSEMBLY

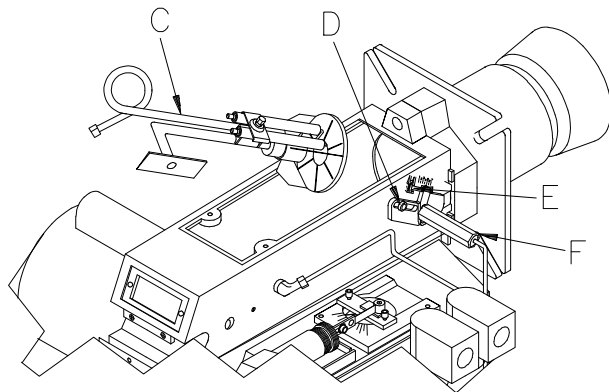

To adjust nozzle assembly (C), loosen screw (D) and move the nozzle forward or retract by turning the adjustment screw (E). Line up the pointer on the locating block to the index position specified in Table 22-2 (pg. 9) for best results.

To remove the nozzle, remove the burner cover and disconnect the electrode cables. Separate the nozzle assembly from the fan housing by loosening the connecting pipe (F) and extracting the connecting pipe from the nozzle port. Then disconnect the 2nd stage oil line from the fitting located on the inside of the fan housing.

Figure 22A-6

IGNITION ELECTRODE ADJUSTMENT

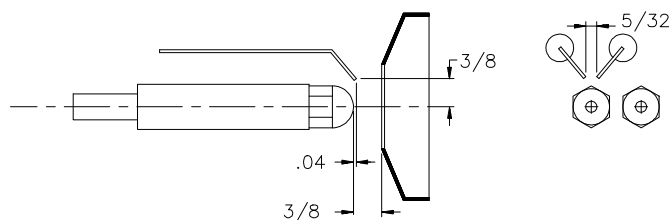

Check that the measurements between the nozzle, the ignition electrodes and the pressure plate correspond to Figure 22-7.

Figure 22A-7

PVI FIREPOWER[®]

NOZZLE POSITION

INPUT - GPH	NOZZLE POSITION
1.4	1
2.8	3
4.3	4
5.7	2
7.2	2
8.6	4

TABLE 22-2

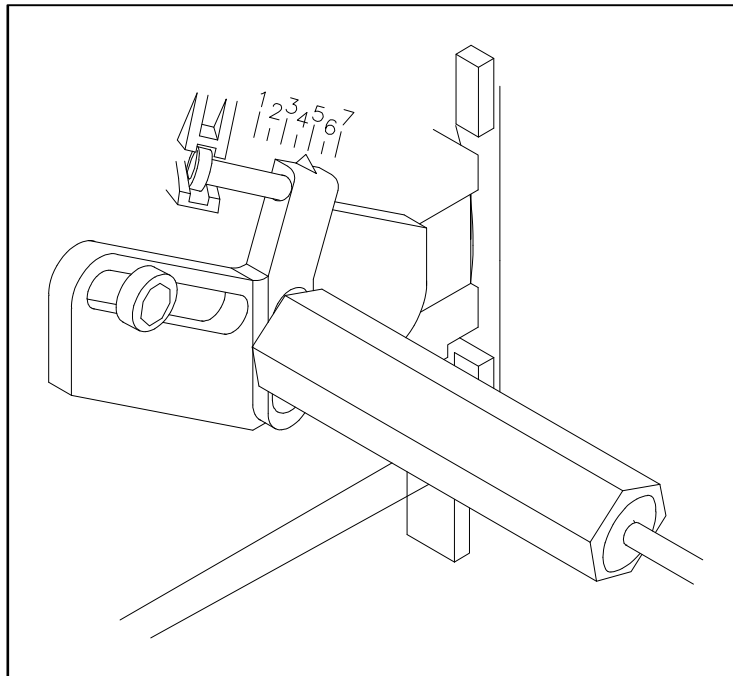

Figure 22A-8

PVI FIREPOWER[®]

TROUBLESHOOTING SUGGESTIONS

OIL BURNER

1. BURNER FAILS TO START:

- A. **Defective on/off or fuel transfer switch.** Replace switch.
- B. **Control circuit has an open control contact.** Check limits, low water cutoff, proof of closure switch and others as applicable.
- C. **Bad fuse or switch open on incoming power source.** Correct as required.
- D. **Motor overloads tripped.** Reset and correct cause for trip out.
- E. **Flame safeguard control safety switch tripped out.** Reset and determine cause of apparent flame failure.
- F. **Loose connections or faulty wiring.** Tighten all terminal screws and consult wiring diagram furnished with the burner.
- G. **Frozen oil pump shaft preventing blower motor operation.** Replace oil pump.
- H. **Flame safeguard control starting circuit blocked due to flame relay being energized.** Possible defective scanner or photocell - replace. Possible defective amplifier - replace. Scanner actually sighting flame due to leaking fuel valve - correct unwanted flame cause. Defective flame safeguard control - replace.
- I. **Defective blower motor.** Repair or replace.

2. OCCASIONAL LOCKOUTS FOR NO APPARENT REASON:

- A. **Check for proper settings on direct spark oil ignition electrodes.** Make certain that gap is not too wide and the "light-off" oil pressure is as recommended.
- B. **Direct spark ignition.** Verify that there are no cracks in the porcelain and that transformer end and electrode end plug-in connections are tight.
- C. **Loose or broken wires.** Check all wire nut connections and tighten all terminal screw connections in panel and elsewhere as appropriate.

- D. **Occasional low supply voltage.** Contact local utility to correct. Make certain the burner control circuit transformer (if supplied) is correct for the voltage and power (VAC) being supplied.

3. BURNER MOTOR RUNS, BUT DIRECT SPARK IGNITED OIL FLAME IS NOT ESTABLISHED:

- A. **Defective or incorrect size oil nozzle.** Remove and clean or replace.
- B. **Low oil pressure.** Check with gauge for correct "light-off" pressure.
- C. **Defective oil pump.** Replace.
- D. **Defective oil solenoid valve.** Replace.
- E. **Oil pump coupling loose and defective.** Replace or tighten as required.
- F. **Low oil pressure switch (if supplied) defective or incorrectly set.** Adjust or replace switch.
- G. **Ignition transformer defective.** Replace.
- H. **Ignition electrode set incorrectly.** Remove electrodes and reset.
- I. **Ignition electrodes cracked and grounding out spark.** Replace electrodes.
- J. **Ignition leadwire defective and grounding out spark.** Replace.
- K. **Ignition plug in connections at transformer or electrode loose.** Tighten.
- L. **Air flow switch not making circuit.** Adjust set point or replace.
- M. **Defective flame safeguard control or plug in purge timer card.** Replace.
- N. **Air dampers held in high fire position due to mechanical binding of linkage.** Readjust linkage.
- O. **Loose wiring connections.** Check and tighten all connections.

PVI FIREPOWER[®]

TROUBLESHOOTING SUGGESTIONS

OIL BURNER (con't)

4. OIL FLAME IGNITES, BUT THEN FLAME SAFEGUARD CONTROL LOCKS OUT ON SAFETY:

- A. **Flame scanner lens dirty.** Remove and clean.
- B. **Scanner sight tube blocked or dirty.** Check and clean.
- C. **Flame scanner defective.** Replace.
- D. **Fuel/air ratios incorrect, resulting in unstable or smoky flame causing scanner flame sighting problem.** Readjust ratios for clean stable flame.
- E. **Defective flame safeguard amplifier or control.** Replace as appropriate.

5. OIL FLAME EXTREMELY SMOKY AT LIGHT-OFF OR IN LOW FIRE POSITION:

- A. **Defective or incorrect size oil nozzle.** Replace.
- B. **Fuel/air ratio incorrect.** Readjust.

6. LIGHT-OFF OIL FLAME IS ESTABLISHED AND PROVEN, BUT BURNER WILL NOT ATTEMPT TO GO TO THE HIGH FIRE POSITION:

- A. **Low/High/Low or modulating burner high fire temperature or pressure control could be defective or not set to call for high fire.** Readjust or replace control.
- B. **Loose wires or incorrectly wired.** Verify wiring and tighten all connections.
- C. **Flame safeguard control or high fire switch (if supplied) defective.** Verify and correct as required.
- D. **Hydraulic oil cylinder defective.** Replace.
- E. **Linkage mechanically binding.** Readjust linkage.

7. LOW OIL FLAME IS ESTABLISHED AND PROVEN, BUT FLAME OUT OCCURS IN TRANSITION FROM LOW FIRE TO HIGH FIRE:

- A. **Defective or incorrect size oil nozzle.** Replace.
- B. **High fire oil pressure too low.** Readjust.
- C. **Air dampers set too far open at low fire, which causes flame to blow out during transition to high fire.** Readjust dampers.
- D. **Oil pump coupling loose or defective.** Tighten or replace.
- E. **Defective oil pump.** Replace.
- F. **Linkage mechanically binding.** Readjust.
- G. **On modulating systems-fuel/air ratios set incorrectly, causing flame to blow out when going to high fire.** Readjust linkage.

8. WHITE SMOKE FORMATION ON OIL FIRING:

- A. **Oil/air ratios incorrect due to excess air, or oil flow is too low.** Readjust for proper fuel input, CO₂ and smoke reading.

9. GRAY OR BLACK SMOKE FORMATION ON OIL FIRING:

- A. **Impingement on cold combustion chamber surfaces due to incorrect oil nozzle spray angle for application.** This could also result in carbon formation on chamber surfaces.
- B. **Defective or dirty oil nozzle.** Replace or clean nozzle.
- C. **Incorrect oil/air ratios.** Readjust burner to correct CO₂ and smoke levels.
- D. **Oil pressure too low resulting in poor atomization.** Readjust.

PVI FIREPOWER[®]

TROUBLESHOOTING SUGGESTIONS

OIL BURNER (con't)

6. OIL HIGH FIRE INPUT RATE CANNOT BE ACHIEVED:

- A. **Oil nozzle size too small. Remove nozzle and check marking.** Replace with correct size nozzle.
- B. **Nozzle defective. Replace. Nozzle mesh filter (if supplied) dirty.** Clean or replace.
- C. **Oil supply pressure to nozzle too low.** Readjust.
- D. **Oil pump defective.** Replace.
- E. **Oil pump coupling loose (slipping) or defective.** Replace.
- F. **Linkage mechanically binding.** Readjust.
- G. **On modulating burner, oil nozzle return line metering valve set incorrectly.** Readjust to attain required nozzle bypass pressure.
- H. **Oil suction line too small or partially blocked.** Make vacuum test while at high fire. The vacuum should not exceed 10-15 inches Mercury (HG). Make line size changes, if required.
- I. **Blocked or dirty suction line oil filter.** Replace or clean.
- J. **Manual valves in suction line not fully open.** Check and correct.
- K. **Suction line check valve or foot valve operating incorrectly.** Check and correct.
- L. **Vent system on oil tank blocked, creating vacuum on tank with high vacuum and lowered oil flow to burner.** Check and correct.

Additional troubleshooting information can be found in the Flame Safeguard bulletin supplied with the burner.