

INSTALLATION & MAINTENANCE MANUAL

MODEL SU-3 GAS BURNER

Inputs 199,000 thru 399,000 Btu/h
(Inputs 58.32 kW thru 116.94 kW)

This burner is for use with Natural Gas or Propane Gas (LP), as specified on the name plate

Installation and service must be performed by a qualified service installer, service agency or the gas supplier.

IMPORTANT: THIS MANUAL CONTAINS INFORMATION REQUIRED FOR INSTALLATION, OPERATION AND MAINTENANCE OF THIS EQUIPMENT. READ AND FOLLOW THE INFORMATION IN THIS MANUAL AND ALL OTHER PROVIDED INSTRUCTIONS, LABELS AND MARKINGS BEFORE INSTALLING, OPERATING OR SERVICING THIS UNIT.

WARNING: If the information and instructions in this manual, the appliance installation and maintenance manual and product markings are not followed exactly, a fire or explosion may result, causing property damage, personal injury or death.

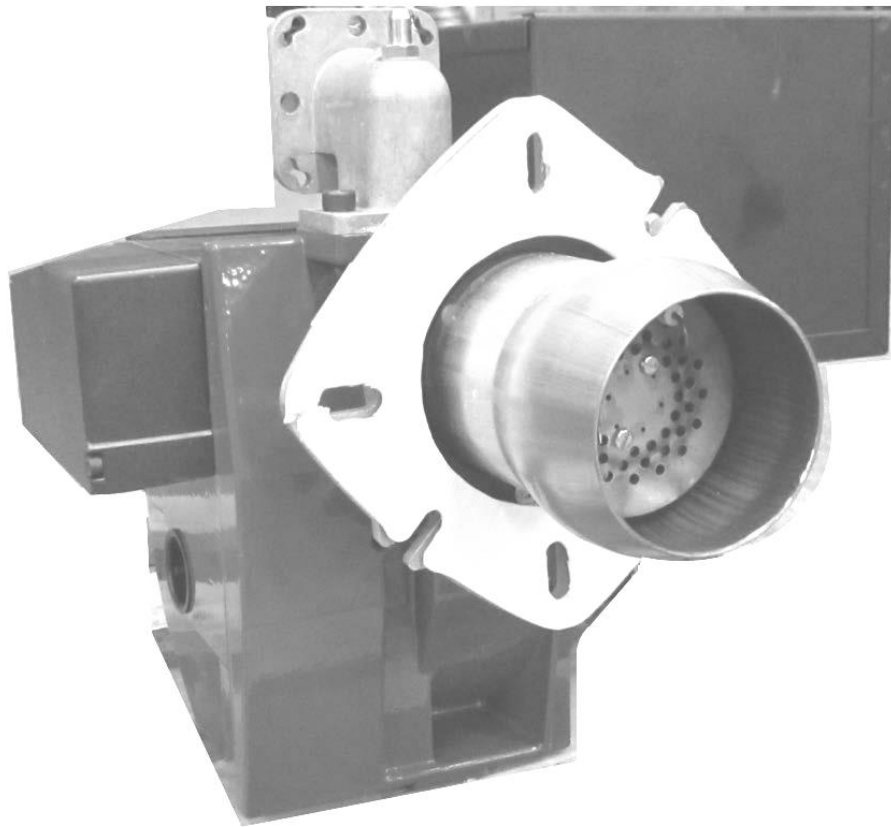

TO THE INSTALLER: After installation, these instructions must be given to the equipment user or left near the appliance.

SPECIAL INSTRUCTIONS TO THE OWNER: Retain this manual for future reference. These instructions contain important information that will help you in maintaining and operating this appliance.



PVI INDUSTRIES, LLC - Fort Worth, Texas 76111 - Web www.pvi.com - Phone 1-800-433-5654

TABLE OF CONTENTS

1. Safety Considerations
2. Codes
3. Electrical Specifications
4. Combustion and Ventilation Air
 - 4.1 Equipment Located in Confined Spaces
 - 4.2 Maximum Allowed Remote Combustion Air Inlet Length
 - 4.3 Vertical or Horizontal Remote Air Duct Termination
 - 4.4 Remote Air Consideration for Combined Remote Air Ducting
5. Venting
6. Gas Supply and Piping
 - 6.1 Gas Train and Controls Certification
 - 6.2 Gas Control Trains
 - 6.3 Inlet Pressure
 - 6.4 Manifold Pressure
 - 6.5 Gas Service and Pipe Capacity
 - 6.6 Gas Piping to Burner
 - 6.7 Appliance Isolation During Gas Supply Piping Pressure
7. Sequence of Operation
8. Burner Operation
9. Electrode & Flame Sensor Positioning
10. Burner Setup and Adjustment
 - 10.1 Commissioning Checklist
 - 10.2 Adjusting Burner Using Combustion Analyzer
 - 10.3 Adjusting Burner Head
 - 10.4 Burner Operation Record
11. Maintenance Instructions
12. Troubleshooting
13. Materials List

1. SAFETY CONSIDERATIONS

WARNING: If the information in these instructions is not followed exactly, a fire or explosion may result, causing property damage, personal injury or death.

FOR YOUR SAFETY

- **Do not** store or use gasoline or other flammable vapors or liquids in the vicinity of this or any other appliance.

WHAT TO DO IF YOU SMELL GAS

- **Do not** try to light any appliance.
- **Do not** touch any electric switch; do not use any phone in your building.
- **Immediately** call your gas supplier from a location away from your building and the smell of gas. Follow the gas supplier's instructions.
- If you cannot reach your gas supplier, call the fire department.
- Seasonal or annual combustion check-out by a qualified service agency is recommended to enable continued safe and efficient operation.

AVERTISSEMENT: Assurez-vous de bien suivre les instructions données dans cette notice pour réduire au minimum le risque d'incendie ou d'explosion ou pour éviter tout dommage matériel, toute blessure ou la mort.

POUR VOTRE SECURITE

- **Ne pas** entreposer ni utiliser d'essence ni d'autres vapeurs ou liquides inflammables dans le voisinage de cet appareil ou de tout autre appareil.

QUE FAIRE SI VOUS SENTEZ UNE ODEUR DE GAZ

- **Ne pas** tenter d'allumer d'appareils.
- **Ne touchez** à aucun interrupteur. Ne pas vous servir des téléphones dans le bâtiment où vous vous trouvez.
- **Appeler immédiatement** votre fournisseur de gaz depuis un voisin. Suivez les instructions du fournisseur.
- Si vous ne pouvez rejoindre le fournisseur de gaz, appelez le service des incendies.

L'installation et l'installation et l'entretien doivent être assurés par un installateur ou un service d'entretien qualifié ou par le fournisseur de gaz.

WARNING: Installation, adjustment and maintenance of this burner must be performed in accordance with this manual and with local codes by a qualified service agency. Improper installation, adjustment, alteration, service or maintenance can result in property damage, personal injury or death.

WARNING: Deadly levels of CARBON MONOXIDE can occur if the burner is not properly operating. Verify proper carbon monoxide levels during first operation and commissioning and following any burner, gas supply, heater or venting change or adjustment. Additionally, have combustion checked annually by a qualified service agency. Failure to verify proper carbon monoxide levels can result in property damage, personal injury or death.

WARNING: Improper installation, adjustment, alteration, service or maintenance can cause injury or property damage. Refer to this manual for assistance, or consult a qualified installer.

WARNING: The burner supplied with this water heater must be adjusted and operated on the gas, at the firing rate and pressures shown on the appliance and burner decals. Firing this burner above the allowed firing rate will void the warranty, and may result in improper operation, a fire or explosion, causing property damage, personal injury or death.

2. CODES

The water heater and burner must be installed in accordance with those installation regulations in force in the local area where the installation is to be made. Authorities having jurisdiction must be consulted before installation is made. In the absence of such requirements, the installation shall be in accordance with the instructions in this manual, the water heater Installation and Maintenance manual, appliance markings and supplemental instructions and in compliance with the Standard for Installation of Domestic Gas Conversion Burners and the latest edition of the National Fuel Gas Code, ANSI Z223.1. Where required by the Canadian authority having jurisdiction, the equipment must be installed in accordance with the latest edition of the Installation Code for Gas Burner Appliances and Equipment CAN/CSA B149.1 and/or B149.2 and applicable Provincial Regulations.

3. ELECTRICAL SPECIFICATIONS

SU-3 Electrical Specifications			
Primary Electric Input	Secondary Electric Input	Total Watts	Total Amps
120 Volt, 60 Hz, 1 Ph	24 Volts	150 Max	3 or less

Electric Wiring

See appliance rating decal for electrical service requirements. The appliance must be electrically supplied and grounded in accordance with the requirements of the authority having jurisdiction or in the absence of such requirements, with the latest edition of the National Electrical Code ANSI/NFPA No. 70. In Canada, the electrical service must conform to local electrical codes and/or CSA C22.1, Canadian Electrical Code, Part 1.

- Connect multi-pin connector at end of flexible conduit from the water heater to the multi-pin plug on the burner control box.
- To avoid serious damage, DO NOT energize the unit until the system and appliance is full of water.
- The burner is grounded through the electrical connection to the water heater. Be certain the water heater has been properly grounded.
- Refer to the burner control wiring diagram located inside the burner control cabinet for further information.

Blower Motor - 120 Volt/ 60 Hz/1 Phase, 1/6 HP PSC motor.

4. COMBUSTION AND VENTILATION AIR

Provisions for adequate combustion and ventilation air to the mechanical room must be in accordance with Section 5.3 "Air for Combustion and Ventilation" of the latest edition of the National Fuel Gas Code, ANSI Z223.1 and/or CAN/CSA B149, Installation Codes or applicable provisions of the local building codes.

4.1 Equipment Located in Confined Spaces

Equipment located in confined spaces requires two openings installed within 12" (30.5 cm) from the top and bottom of the room to assure adequate combustion air and proper ventilation. The total input of all gas utilization equipment installed in the room must be used to determine the required minimum air volume needed for combustion, ventilation and dilution of flue gasses.

- **All Air From Outdoors:**
Each opening requires a minimum free area of 1 square inch (6.45 cm²) per 4000 Btu/hr (1.17 kW) input if directly communicating with the outdoors or communicating to the outdoors through vertical ducts.
Each opening requires a minimum free area of 1 square inch (6.45 cm²) per 2000 Btu/hr (0.59 kW) input if communicating with the outdoors through horizontal ducts.
- **All Air From Inside The Building:**
Each opening requires a minimum free area of 1 square inch (6.45 cm²) per 1000 Btu/hr (0.29 kW) input, but not less than 100 square inches (0.06 m²).
- **Combination Of Air From The Indoors And From The Outdoors:**
Refer to National Fuel Gas Code, ANSI Z223.1 and/or CAN/CSA B149, Installation Codes or applicable provisions of the local building codes.

WARNING: Adequate clean combustion air must be provided to the appliance. Under no circumstances should the appliance ever be under a negative pressure. Particular care should be taken when exhaust fans, compressors, air handling units, etc. may rob air from the appliance. The combustion air supply must be completely free of any chemical or fumes, which may be corrosive to the appliance. Some common chemical fumes to avoid are fluorocarbons and other halogenated compounds, most commonly present as refrigerants or solvents, such as Freon, trichloroethylene, perchlorethylene, chlorine, etc. These chemicals, when in contact with the equipment or when burned, form acids which quickly attack the tubes, flue collector, stack and other appliance and auxiliary equipment. The result of inadequate clean combustion air or negative pressure can be premature unwarranted product failure or unsafe operation producing carbon monoxide that could escape into the building. Exposure to carbon monoxide can lead to injury or death.

4.2 Maximum Allowed Remote Combustion Air Inlet Length (Equivalent Length)

Burners are suitable for use with an optional outside combustion air intake system that may be routed either horizontally or vertically using a field obtained 3" by 4" (7.62 cm by 10.16 cm) increaser and 4 inch (10.16 cm) sealed plastic or metal pipe, extending up to 100 equivalent feet (30.48 equivalent meters). Larger pipe may be used to extend the equivalent length, if the pressure drop is not increased. A UL, ETL, ULC or CSA listed vent cap must be applied to the terminus of the air intake system. The terminus may be either horizontal (from sidewall) or vertical above roof.

The Listed air intake vent termination cap **MUST** be attached to the remote combustion air vent termination to adequately protect the combustion air inlet from wind and weather. A UL Listed air intake termination cap is available from PVI Industries and may have shipped with the water heater and burner as a purchased option.

4.3 Vertical or Horizontal Remote Air Duct Termination

- Air inlet and exhaust vents should terminate in the same wind pressure area whenever possible.
- Air inlet must be located no less than 3 feet (0.91m) below the exhaust terminal if they are within 10 feet (3.05 m) of each other.
- If terminating through the roof, the air inlet must terminate at least 12 inches (0.3 m) above roof level and at least 12 inches (0.3 m) above snow levels.
- If terminating through a sidewall, the air inlet must terminate at least 12 inches (0.3 m) above grade and/or at least 12 inches (0.3 m) above normal snow levels.

4.4 Remote Air Consideration for Combined Remote Air Ducting

When remote air ducting is used, each water heater burner **MUST** have separate combustion air intake piping.

5. VENTING

For appliances connecting to gas vents or chimneys, vent installation and vent size must be in accordance with Part 7, "Venting of Equipment," of the latest edition of the National Fuel Gas Code, ANSI Z223.1, using the "FAN" rating or, in Canada, Section 7, "Venting Systems and Air Supply for Appliances" of the latest edition of the CAN/CSA B149 Installation Codes, or applicable provisions of the local building codes.

- Suitable for use with Category I (non-positive vent static pressure, with a gas vent gas temperature that avoids excessive condensate production in the vent) Type B gas vent systems with 1" (2.54 cm) minimum clearance or Type L vent systems.
- Vent should not be sized based only upon vent connection diameter at the burner.
- Locate units as close as possible to chimney or gas vent. For conventionally vented installations, the connection from the vent to the stack or vent termination outside the building must be made with listed Type "B" double wall (or equivalent) vent connectors and must be direct as possible with no reduction in diameter.
- Support horizontal portions of the venting system to prevent sagging. Horizontal runs must slope upwards not less than 1/4 inch per foot (21 mm/m) from the appliance to the vent terminal. Follow manufacturer's instructions.
- Do not connect vent connectors serving this Category I, natural/negative draft vented, appliance to any portion of a mechanical draft system operating under positive pressure.
- Vent pressure must be between -.02" to -.06" W.C. (- 0.005 kPa to - 0.015 kPa) (Negative Pressure).
- A barometric damper (draft control) is supplied for use on conventional vented installations. A properly installed and adjusted barometric damper helps stabilize draft and regulate high updraft. Conventional vented multiple unit installations with combined venting require barometric dampers to regulate draft at each unit. Adjust the barometric damper to 0.04 inches water column (0.01 kPa) updraft. Follow the barometric damper manufacturer's installation instructions.
- A listed vent terminal suitable for Category I products **must** be installed to adequately protect the gas vent from wind and weather.
- The vent terminal must extend at least 3 ft (.09 m) above the highest point where it passes through the roof of a building and at least 2 ft (.06 m) higher than any portion of a building within a horizontal distance of 10 ft. (3.0 m).
- The vent cap must terminate at least 3 feet (0.91 m) above any forced air inlet within 10 feet (3.05 m); 4 feet (1.22 m) below, 4 feet (1.22 m) horizontally from or 1 foot (0.3 m) above any door, window or gravity air inlet to the building; 1 foot (0.3 m) above grade, 1 foot (0.3 m) above normal snow levels and shall terminate at least 7 feet (2.13 m) above grade when located adjacent to public walkways or gathering areas.
- The vent terminal must not be installed closer than 3 feet (0.91 m) from an inside corner of an L-shaped structure.

6. GAS SUPPLY AND PIPING

Verify that the type of gas specified on rating plate is supplied to the unit. This unit is orificed for operation up to 2000 feet (610 m) altitude. Appliance Btu/h (kW) output derates 4% per 1000 feet (305 m) elevation above sea level. Consult Factory for installations above 2000 feet ((610 m) elevation.

6.1 Gas Train and Controls Certification - NOTE: The gas train and controls assembly provided on this unit have been tested under the applicable American National Standard to comply with safety and performance criteria such as proper ignition, combustion and safety shutdown operation.

6.2 Gas Control Trains - All models include gas control trains with the following components: main manual shutoff valve, two safety shutoff valves and pressure regulator. These components may be separate or two or more may be combined in a common housing.

CAUTION: Do not adjust or remove any screws or bolts on gas train control components which are sealed with a red or blue colored compound. Doing so will void all approvals and warranties.

6.3 Inlet Pressure - Measure at the inlet pressure at the inlet pressure tap located on the upstream side (side away from burner) on the top of the combination gas valve. The inlet pressure must remain within the minimum and maximum values while the unit is at rest and while the unit is operating at maximum firing rate.

INLET PRESSURE	NAT. GAS	LP
Maximum Static Pressure (Inches-Water Column)	10.5" (2.62 kPa)	13" (3.24 kPa)
Minimum Flow Pressure (Inches-Water Column)	4.5" (1.21 kPa)	8" (1.99 kPa)

6.4 Manifold Pressure - Measure the manifold pressure at the manifold pressure tap located on top of the silver elbow attached to the burner head. The rated manifold pressure appears on the burner data label located on side of the burner control panel and is duplicated on the decal located near the front of the water heater.

6.5 Gas Service and Pipe Capacity - Before connecting the burner to the gas supply, insure that the gas pipes and service meter are large enough to permit the additional load of the gas burner. (See Pipe Capacity Table)

Pipe Capacity for Natural Gas Table*(x 1,000 Btu/h's)				
Pipe Length**	Nominal diameter of pipe in inches			
	1"	1 ¼"	1 ½"	2"
15'	345	750		
30'	241	535	850	
45'	199	435	700	
60'	173	380	610	
75'	155	345	545	
90'	141	310	490	
105'	131	285	450	920
120'	120	270	380	850
150'	109	242	300	780
180'	100	225	225	720

* Using 0.6 Specific Gravity Gas and a Pressure Drop of 0.3" of Water Column
Multiplier for Propane: 1.57

** Each 90° elbow counts as 3' for the purpose of these calculations

Pipe Capacity Example:

There is 75 feet of 1¼" pipe from the meter to the burner and there are 5 elbows.

(5 elbows X 3') + 75' pipe = 15' + 75' = 90' of effective pipe length.

The maximum Btu/h that can be fired is 310,000 Btu/h. (See Pipe Capacity Table)

6.6 Gas Piping to Burner

All Piping Must Conform To Local Codes. Use black steel pipe and malleable iron fittings (**do not use cast iron parts**) with a suitable pipe dope which is resistant to liquefied petroleum gases.

- Safe operation of unit requires adequate gas supply with the required static and dynamic (flow) pressures. Actual piping selection depends on many variables that must be carefully considered by the gas piping system designer.
- Do not select gas pipe sizes based only on the supplied tables. These tables are for use by the gas piping system designer as a reference in checking pipe size selections.
- The required gas pipe size may be larger than pipe connection size to the burner.
- It is advisable to run a separate gas line from the meter to the gas burner to avoid pressure drops.
- Installation of a union is suggested for ease of service.
- Install a manual main gas shutoff valve, as specified by Code, approximately 6 feet (1.8 m) away from unit.
- A sediment trap (drip leg) **MUST** be provided in the inlet of the gas connection to the unit.

6.7 Appliance Isolation During Gas Supply Piping Pressure

WARNING: The gas valve must not be subjected to more than ½" psig (3.45 kPa). Subjecting the gas valve to pressure above ½" psig (3.45 kPa) can damage the valve and can cause gas leaks or loss of gas control, which can result in property damage, personal injury or death.

The burner must be isolated during gas leak tests. The burner and its combination gas valve must be disconnected from the gas supply piping system during any pressure testing of that system at test pressures in excess of ½” psig (3.45 kPa). The appliance must be isolated from the gas supply piping by closing its individual manual shut off valve using the gas control knob on top of burner combination valve during any pressure testing of the gas supply piping system at test pressures equal to or less than ½” psig (3.45 kPa).

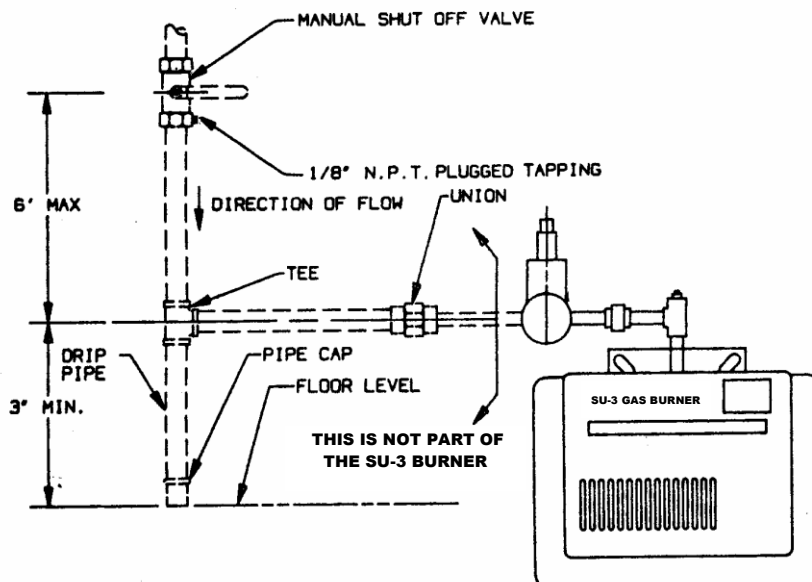

Gas Burner Piping
(Piping upstream of burner combination gas valve supplied by others)

7. SEQUENCE OF OPERATION – Fenwal #35-66

- Limits close.
- Blower motor starts as the 24 Volt transformer powers the airflow switch.
- When the airflow switch is proven, the 35-66 control initiates a pre-purge of approximately 15 seconds.
- At the end of the pre-purge, the spark is energized for 4 seconds. At the same time, the 24 Volt transformer powers the gas valve, allowing the fuel to flow. (The combination gas valve contains two separate automatic safety shutoff valves, a pressure regulator and a manual shutoff valve)
- Within 4 seconds, the flame should be established and proven. The spark will shut off and the control will hold power to the gas valve until the limits open and the burner stops firing.
- If the flame is not established, the blower motor continuously runs.

To restart, power should be interrupted for five minutes. Then turn on the power to start this sequence again.

WARNING: Should overheat occur, shut off the manual gas shut off valve to control the appliance. Do not shut off the control switch to the pump or blower, which provides burner cooling and post purge. Failure to follow this warning may result in a fire or explosion, causing property damage, personal injury or death.

En cas de surchauffe : (1) fermez la commande manuelle de gaz à l'appareil, (2) ne pas fermer la commande de la pompe ou de la soufflerie.

8. BURNER OPERATION

Before placing the burner in service, a qualified installer, service agency or the gas supplier must perform installation and service. All piping must conform with local codes.

Do **not** try to light the burner by hand.

Lighting Instructions

1. Set the thermostat to the lowest temperature.
2. The control knob on the gas valve should be in the "OFF" position for at least five minutes.
3. Rotate the control knob counter-clockwise to the "ON" position and set the thermostat to the desired temperature settings. The burner will energize on call for heat.

Reset, If Flame Lockout Occurs

1. Turn the thermostat off or turn the main power off.
2. Wait five minutes.
3. Return thermostat to the desired setting or turn the main power on.

To Shut the Burner Off

1. Set the thermostat to the lowest temperature.
2. Turn off all electrical power to the appliance if service is to be performed.
3. Rotate the control knob on the gas valve to the "OFF" position.

9. ELECTRODE AND FLAME SENSOR POSITIONING

Two electrodes act as a sparker and a flame rod. Flame rectification by this flame rod monitors the continued presence of the burner flame.

ELECTRODE AND FLAME SENSOR POSITIONING

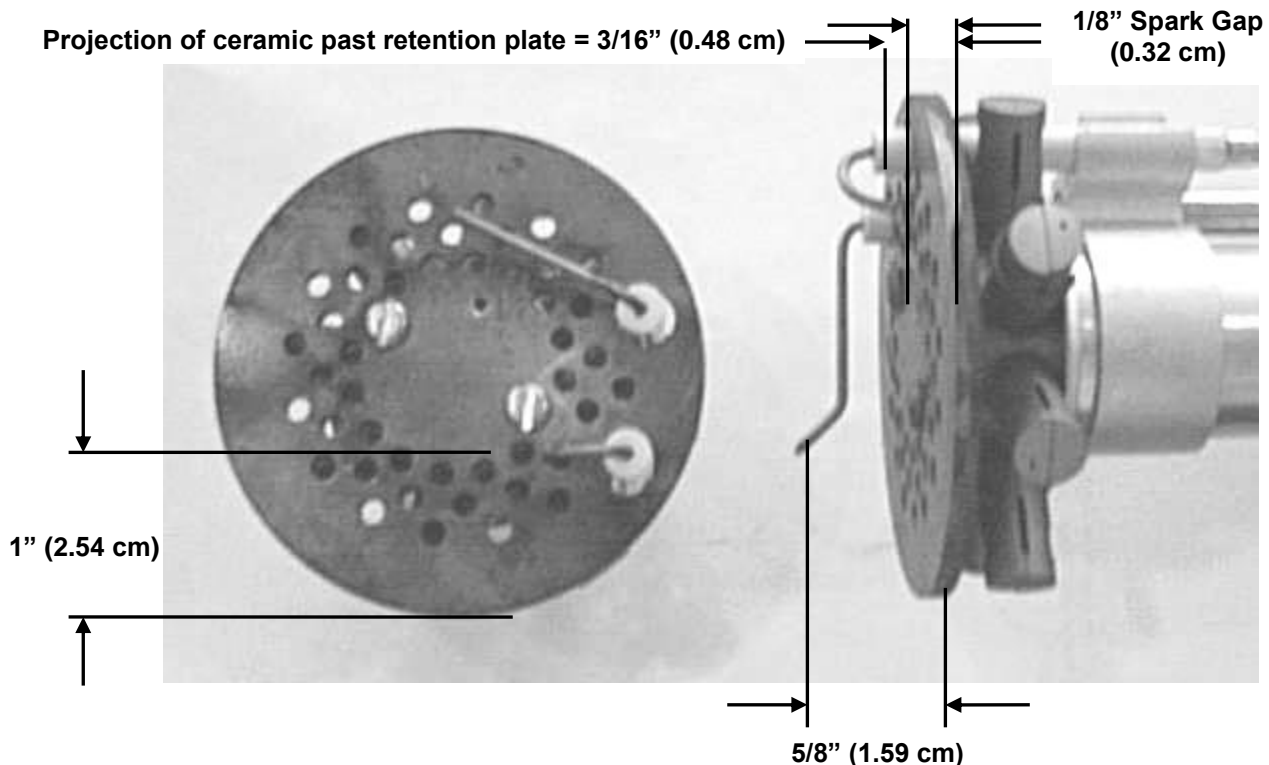

Number and positioning of holes in pressure plate (head) may vary.

10. BURNER SETUP AND ADJUSTMENT

WARNING: The burner supplied with this water heater has been factory adjusted to operate on the type gas, gas pressure, manifold pressure and firing rate identified on the burner data decal and must be verified after installation and adjusted as required to obtain those values. Firing this burner above the burner decal specified firing rate will void the warranty, and may result in improper operation, a fire or explosion, or dangerous carbon monoxide, causing property damage, personal injury or death.

See the burner and water heater data decals for the proper firing rate, gas pressure requirements and other important information.

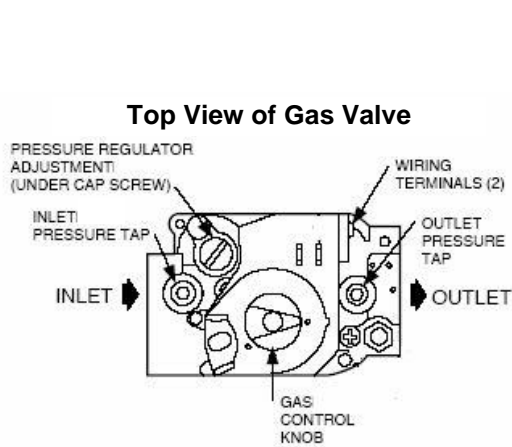
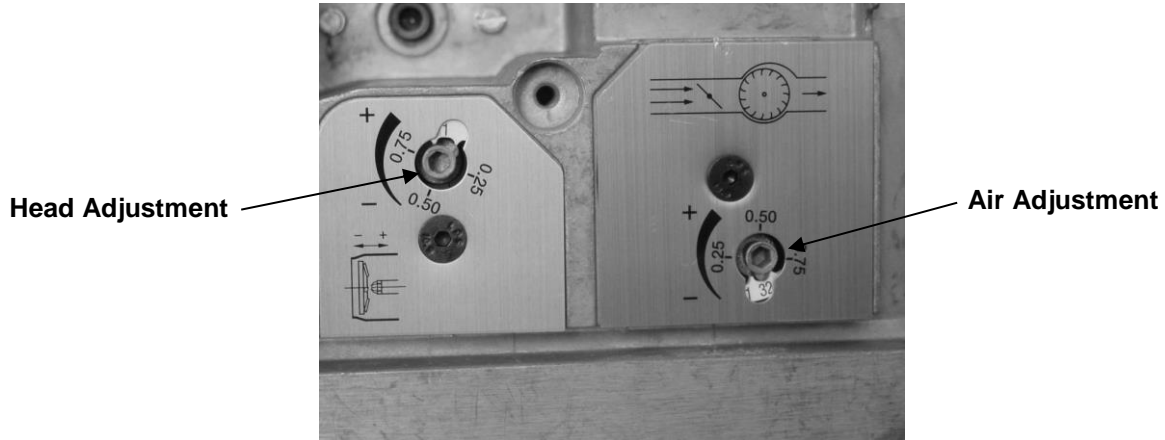

Top View of Gas Valve

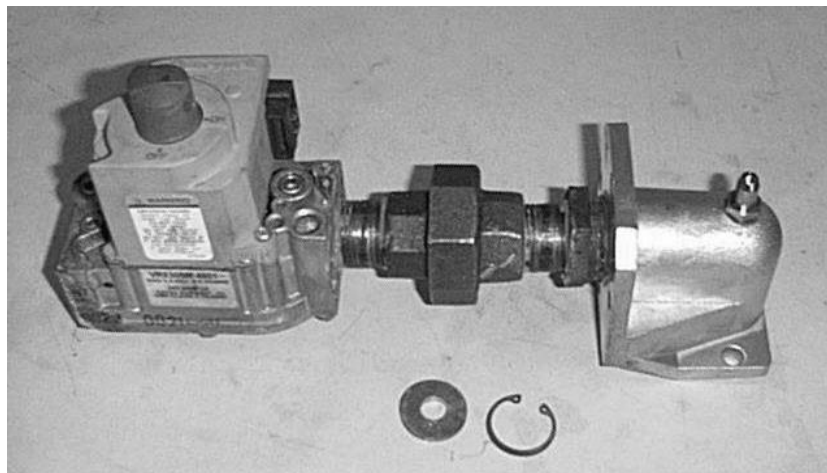
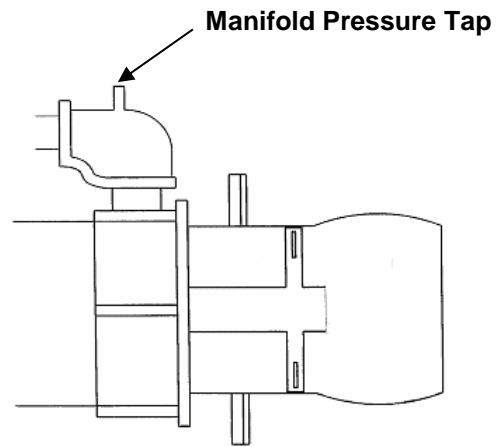

SU3 Gas Manifold

10.1 Commissioning Checklist

1. Be sure the water heater tank is filled with water before commissioning the burner.
2. Check the combustion air, venting and gas supply complies with the Section 4, "Combustion and Ventilation Air", Section 5, "Venting", and Section 6 "Gas Supply and Piping".
3. Check burner wiring.
 - Check that 120VAC is coming into the burner.
 - Check that the burner is properly grounded using a ground wire.
 - Check the polarity to the burner is correct. (To check polarity: Set a multimeter to VAC. Touch L1 to one of the probe tips and ground to the other. If a voltage between 110 and 125 is shown then it has the correct polarity; if any other reading is shown, then check the L2 wire. If the L2 wire shows a voltage between 110 and 125 is shown then the polarity to the burner is reversed.)
4. Check that the orifice is installed. All SU-3 burners, except natural gas burners with inputs above 199,000 btuh (58.32 kW), have an orifice installed in the burner's gas pipe union. If the required orifice is missing, contact PVI for a proper size replacement.
5. Install monometers at the inlet pressure tap and manifold pressure tap on the burner.
 - Check the gas pressure at the gas valve inlet pressure tap (line pressure). This pressure must be within the minimum and maximum gas pressures printed on the burner data decal, both when the burner is firing and when it is not firing. If the pressure drops and then surges back up, double check the piping, because it means the gas supply is probably undersized.
 - Record the static incoming gas pressure. When the burner lights off, record the running incoming gas pressure; **the incoming gas pressure must never be above or below the minimum and maximum pressures shown on the burner information decal, whether the burner is firing or not.**
 - Check the manifold pressure at the manifold pressure tap located on top of the silver elbow attached to the burner head. **Note: When checking manifold pressure, do not subtract burner housing pressure during valve-on delay (pre-purge).**

10.2 Adjusting Burner Using Combustion Analyzer

- While the burner is firing and with a combustion analyzer sampling flue products in the vent near the burner, adjust the gas pressure regulator as required to match the manifold pressure shown on the burner data decal. If adjustments need to be made, remove the cap screw and adjust the pressure regulator. Screwing the regulator clockwise will increase the manifold pressure and counter-clockwise will decrease the manifold pressure. **Note that a slight turn of the adjustment screw can result in a very large change in manifold pressure.**
- Adjust the air shutter as necessary to obtain a CO₂ reading between 8% and 9.5% for Natural gas and 9.5% to 10.5% for LP gas (O₂ between 4.5% and 7.0%). Carbon monoxide levels should be below 200 ppm (less than 100 ppm is preferred). If air shutter adjustment is needed, rotate the air adjustment screw clockwise to open the air shutter or counter-clockwise to close the air shutter. Changing the air shutter setting will require the manifold pressure to be readjusted to match the pressure shown on the burner information decal.
- Continue to adjust the burner's gas regulator and air shutter until the manifold pressure matches the value shown on the burner data decal and CO₂ (or O₂) and Carbon Monoxide is within the range specified above.

10.3 Adjusting Burner Head

- Do not change the factory setting of the burner head, except as directed in Section 12, Troubleshooting.
- If directed to change the burner head position number, with the burner firing and with a combustion analyzer inserted in the flue and a manometer attached to the manifold pressure tap, use an allen wrench to rotate the head adjustment screw clockwise to increase the burner head position number or rotate counter-clockwise to decrease the burner head position number. Changing the burner head position will require the manifold pressure to be readjusted to match the pressure shown on the burner data decal. Then follow the instructions contained in section 10.2, Adjusting Burner Using Combustion Analyzer.

10.4 Burner Operation Record

Note: if any adjustments are made, it is important to recheck the manifold pressure and combustion analysis. Check the following readings in the vent above the flue collector and below the barometric damper.

BURNER OPERATION: Record the Readings at Steady State	
Incoming Static Gas Pressure = "W.C. (kPa) (see burner data decal for range)	
Incoming Flow Gas Pressure = "W.C. (kPa) (see burner data decal for range)	
Manifold Gas Pressure = "W.C. (kPa) (see burner data decal for specified pressure)	
CO ₂ % = (8% to 9.5% for Natural gas) (target 8.5%) (9.5% to 10.5% for LP gas) (target 10.0%)	
O ₂ % = (7.0% to 4.5%)	
Carbon Monoxide (CO) in PPM = (should not exceed 200PPM) (target <100PPM)	
NO _x in PPM (If necessary)	
Stack Temperature – Gross °F (300°F minimum, 500°F maximum)(149°C to 260°C)	
Room Temperature °F (°C)	
Draft (should be - 0.02 "W.C. to - 0.06 "W.C.)(- 0.005 kPa to - 0.015 kPa) (target - 0.04" W.C.) (- 0.01 kPa)	
High Gas Pressure Switch Setting (if equipped)	
Low Gas Pressure Switch Setting (if equipped)	
Head Setting Number	
Air Shutter Setting Number	
Running Motor Amps and Volts	
Stored Water Temperature °F (°C)	
Vent Diameter	

11. MAINTENANCE INSTRUCTIONS

At least once a year, a qualified service agency needs to be contracted for other than routine maintenance, including such things as checking the burner head and checking combustion.

WARNING: Turn off all electrical service to the appliance when accessing the limit or other controls located inside the appliance or burner control cabinet. This cabinet contains High Voltage wiring and terminals. Close and fasten the control cabinet cover before restoring electrical service to the appliance. If the electrical service is not turned off and these terminals are touched, a dangerous shock causing personal injury or death could occur.

CAUTION: Label all wires prior to disconnection when servicing controls. Wiring errors can cause improper and dangerous operation. Verify proper operation after servicing.

ATTENTION: Au moment de l'entretien des commandes, étiquetez tous les fils avant de les débrancher. Des erreurs de câblage peuvent entraîner un fonctionnement inadéquat et dangereux. S'assurer que l'appareil fonctionne adéquatement une fois l'entretien terminé.

1. Keep the area around the conversion burner clear and free from combustible materials, gasoline, and other flammable vapors and liquids.
2. The blower motor is the only moving part. It does not require lubrication, since the ball bearings have been permanently lubricated.
3. The user should do periodic visual checks of the burner and the flame.
4. Check for obstruction of combustion air and ventilating air flow.
5. Periodically inspect and checkout the burner ignition, control system, and fuel valve operation (for tight close-off).
6. Examine the venting system at least once each year for proper connections, alignment and corrosion.
7. The blower inlet will collect dust from the air during operation. Disconnect the power to the heater and clean the blower wheel when necessary.
8. Inspect all parts and make replacements when necessary.
9. Check wiring for loose connections and burned wires.

12. TROUBLESHOOTING

Condition	Solutions
1. Burner motor runs and:	
No flame after pre-purge	Check 24V feed to airflow switch & after airflow switch to control. Fix or replace the airflow switch. If there is no secondary power, then replace the 24V transformer.
No flame, faulty ignition transformer or spark separately	Check ignition transformer output from Fenwal control and check for cracked electrode or gap. Fix or replace.
Burner locks out after 4 seconds	First, check ionization electrode, ionization cable (for cracks) and boot. Fix as needed.
Polarity reversed	Check power feed for reversed polarity following instructions in the Commissioning Checklist, Section 10.1.
Bad earth grounding	Fix the ground wire.
Gas supply pressure is too low	Check the gas supply regulator and adjust to proper pressure, check that gas piping is adequately sized following the instructions in Section 6, Gas Supply and Piping.
2. Pulsation – * Follow the instructions in Section 10, Burner Setup and Adjustment and using a combustion analyzer, readjust combustion air as required to obtain proper combustion.	
Gas pressure is too high.	Use manometer and readjust the inlet pressure. *
Manifold pressure too high	Use manometer and readjust regulator for correct manifold pressure.*
Burner is dirty	Clean burner.
Venting is inadequate	Adjust barometric damper, clear flue and cap of foreign materials or correct vent system following the instructions in Section 5, Venting, to provide draft within the specified range.
Misadjusted burner head	First correct by steps above, if still pulsating, adjust to a lower head position number. Manifold pressure must be readjusted to match that shown on the burner information decal and combustion must be rechecked following the instructions in Section 10, Burner Setup and Adjustment.
3. Burner locks out	
Ionization current is too low	Check current. Minimum 0.8 micro amps. Check position of ionization electrode and the condition of the cable.
4. The CO content is too high	
Excess air is too low or possibly too high	Adjust air shutter.
The gas holes in pressure plate are clogged	Clean them.
The fresh air intakes are too small	Increase the size of combustion air openings to those specified in Section 4, Combustion and Ventilation Air.
Negative pressure in mechanical room	Remove source of negative pressure and/or increase size of combustion air openings.
Gas supply is too high or too low	Check the gas supply regulator adjust to proper pressure, check that gas piping is adequately sized following the instructions in Section 10, Burner Setup and Adjustment.
Burner settings or adjustment incorrect	Follow the instructions in Section 10, Burner Setup and Adjustment and using a combustion analyzer.
5. Condensation in the heat exchanger	
Firing Rate is too low	Check burner combustion. If combustion is in range, increase firing rate so the gross stack temperature is at least 350°F (177°C) by adjusting to a higher head position number. Manifold pressure must be readjusted to match that shown on the burner information decal and combustion must be rechecked following the instructions in Section 10, Burner Setup and Adjustment. If allowed by code and vent manufacturer, insulate the vent.

13. MATERIALS LIST

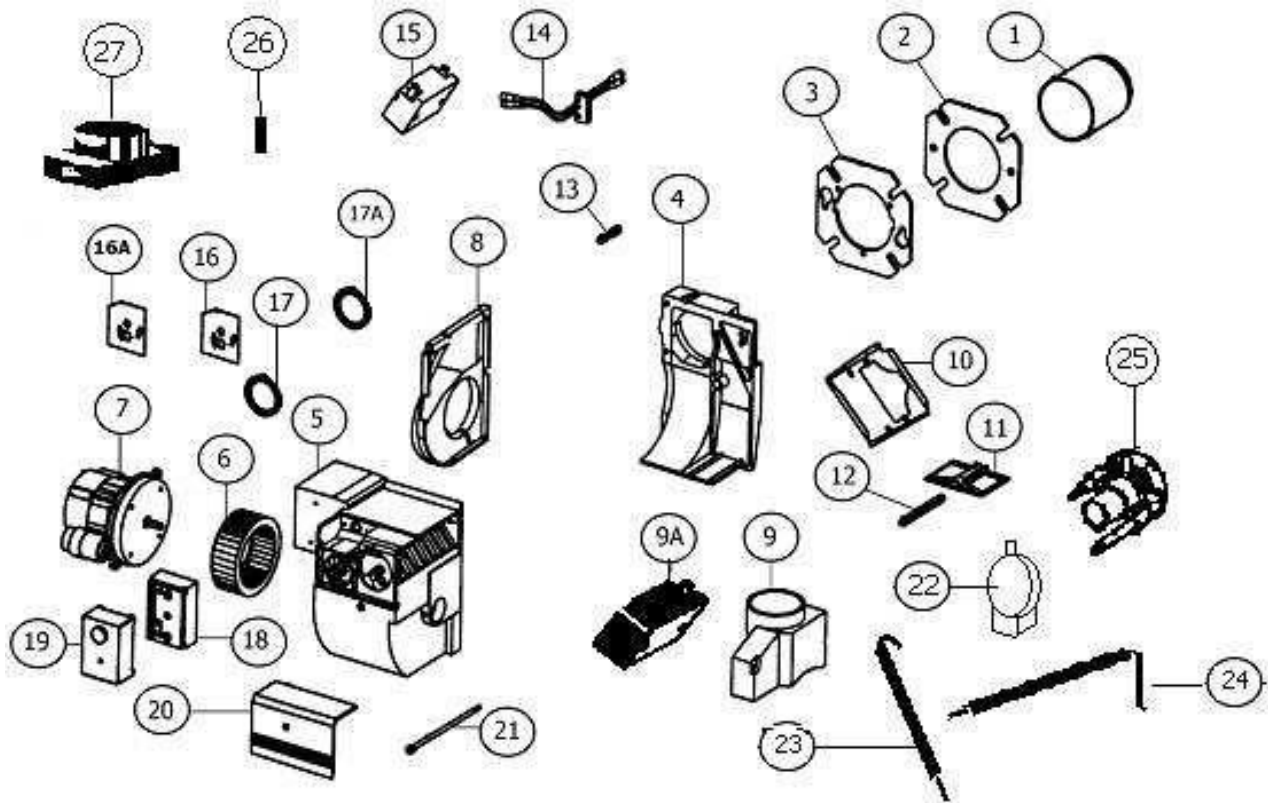

ITEM	Part #	PART	ITEM	Part #	PART
1	118916	Blast Tube	14	119167	Ionization Cable
2	101329	Flange Gasket	15	101630	Ignition Transformer
3	101306	Adjustable Flange	15A	5734 & (2) 5315	Ignition Cable for 2260-TWO
4	118941	Front piece - Housing	16	118936	Cover Plate - Air Regulation
5	119183	Rear piece - Housing	16A	118937	Cover Plate - Nozzle Line
6	110195	Fan Wheel -133 mm (199, 270, 300)	17	118938	Scale - Nozzle Line
6A	119166	Fan Wheel -146 mm (399 only)	17A	118939	Scale -Air Regulation
7	106419	1/6 HP PSC Blower motor	18	107552	24 Volt Transformer
8	119181	Shielding Plate Housing	19	102785	Safety Control
8A	119165	Plate for Cone (399 only. Not shown)	20	118929	Plastic Cover Plate
9	101315 &101041	Outside Air Boot (optional)	21	118918	Screw (Long Special)
9A	118930	Silencer	22	110995	Airflow Switch
10	118917	Air Regulation Plate	23	119187 Assy	Ignition Electrode
11	118921	Air Damper	24		Flame Rod
12	118922	Air Regulation Adjustment screw	25		Retention head
13	118935	Adjustment Screw – Nozzle Line	26	5928	Union
			27	102415	Gas Valve
				-	Gas Orifice (varies by model , gas & input) Located in union (not shown)

