



Installation Instructions – Supplemental

PLATINUM® LP GAS TO NATURAL GAS CONVERSION INSTRUCTIONS

For all models using a White Rodgers Gas Valve – (see PV6820 for Dungs gas valve conversion instructions)

Conversion and Startup of a PLATINUM® water heater for operation with alternate fuel must be performed by qualified service personnel. These instructions are to supplement the Installation and Maintenance Manual provided with your PLATINUM® water heater.

Before you begin, read and follow these instructions, as well as the information contained in the PLATINUM® Installation and Maintenance Manual. To obtain an additional copy, or for any questions, call PVI Industries, LLC at 1-800-433-5654.

WARNING: If the information in the supplied instructions and manual(s) is not followed exactly, a fire, explosion, exposure to hazardous materials or other hazards may result, causing property damage, personal injury or loss of life.

WARNING: High Voltage Shock Potential: Turn off all electrical service to the appliance prior to installation of this kit. Close any opened panel covers before restoring electrical service to the appliance. All wires and terminals may carry High Voltage (120VAC). If the electrical service is not turned off and terminals are touched, a dangerous shock may result, causing property damage, personal injury or loss of life.

WARNING: When servicing the controls, exact factory authorized replacement parts must be used, all wires must be labeled prior to disconnection and proper operation must be verified after servicing. Incorrect parts substitution or wiring errors can may result in a fire, explosion, exposure to hazardous materials or other hazards may result, causing property damage, personal injury or loss of life.

CODES

Read and explicitly follow the entire procedure and heed all warnings and cautionary statements detailed in the Installation and Maintenance Manual regarding the installation and operation of the PLATINUM®. The conversion of the PLATINUM® shall conform to those installation regulations in force in the local area where the installation shall take place. These instructions should be followed carefully in all cases. Authorities having jurisdiction shall be consulted before conversion is made. In the absence of such requirements, the conversion shall conform to the latest edition of the National Fuel Gas Code, ANSI Z223.1. Where required, the conversion shall be carried out in accordance with the requirements of the provincial authorities having jurisdiction and in accordance with the requirements of the Canadian Code CSA-B149.1, Natural Gas and Propane Installation Code.

INSTRUCTIONS

These are the steps for conversion of PLATINUM® water heaters from LP to Natural Gas, for all models. This PLATINUM® is orificed for operation up to 2000 feet altitude. Unit derates 4% per 1000 feet above 2000 feet elevation. Consult Factory for installations above 2000 feet elevation. Consult factory for altitude deration assistance.

1. Disconnect the electrical power.
2. Turn off the gas supply.
3. Remove lower front jacket cover to expose the burner and gas train assembly.
4. Remove the plastic condensate plumbing by opening the two unions and set the plumbing aside.

5. Locate and open $\frac{1}{2}$ union between gas valve and blower.
6. Remove the aluminum gas orifice from the union.
7. Replace the orifice with the factory supplied Natural gas orifice. Consult factory for assistance in selecting the appropriate orifice. This step is crucial to safe operation. Failure to do so could cause unreliable operation or the creation of dangerous carbon monoxide.

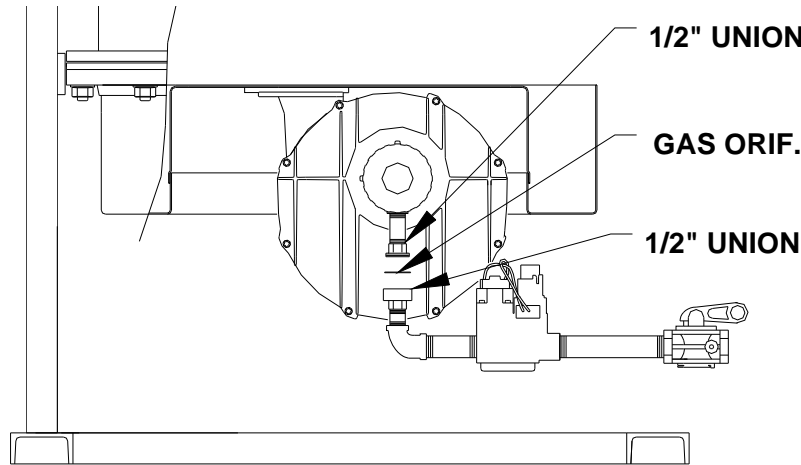

Fig 1. REPLACE ORIFICE

8. Carefully reassemble the union with the orifice and tighten the union using pipe wrenches.
9. Locate the brass regulator cap on the top of the gas valve. This is a tamper resistant fitting. Using a fine-bladed screw driver or awl that fits into one of the two divots in the brass, remove the plug by turning it counter-clockwise. The regulator can now be adjusted using the plastic screw under the brass cap.
10. Turn the gas back on and check the inlet plumbing for any gas leaks using commercially available leak detector or a soap bubble solution.
11. Follow the LIGHTING INSTRUCTIONS of the PLATINUM Installation and Maintenance manual (turn on electrical power and adjust the thermostat to obtain a call for heat).
12. Use a commercially available leak detector or soap bubble solution to check the gas train for leaks. All joints should be free of any leaks. Any leaks must be repaired prior to operating the heater
13. Check the inlet/supply gas pressure before startup, using a U-tube manometer or a 0 to 28" W.C. pressure gauge for inlet gas pressure. (This is the pressure measured before all components in the gas train.) The manometer must stay connected throughout the testing to monitor the inlet gas pressure while the burner is firing. Record static pressure when not firing and record flow pressure while firing and ensure these pressures do not exceed 10.5"WC and is not below the 4.5"WC. Pressures outside this range could result in gas valve damage, unreliable operation or the creation of dangerous carbon monoxide.
14. Check the manifold gas pressure during operation, using a U-tube manometer or a 0 to 28" W.C. connected to the port on the outlet side of the gas valve (labeled PRESS TAP).
15. Check the flue gases with an electronic combustion analyzer to make final adjustments to the gas pressure regulator.
 - a. Readings should be taken through a small hole in the vent located no more than 12 inches downstream of the appliance flue outlet.
 - b. Measure the vent pressure using a manometer or draft gauge capable of reading up to 1/2" W.C. and record vent pressure. Vent pressure must not exceed +0.4" W.C. Excessive vent pressure indicates a vent obstruction or inadequately sized vent.
 - c. When water in tank is above 120°F, insert the analyzer sensor into the hole in the vent and record O₂ reading.

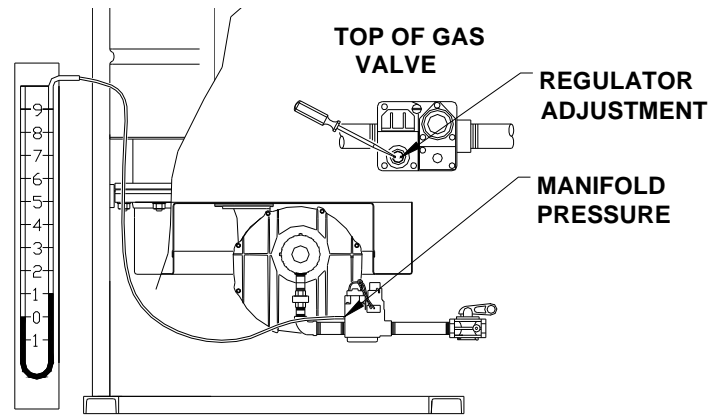

Fig 2. ADJUST REGULATOR

- d. Using a screwdriver, rotate the regulator adjustment to obtain an O₂ level between 4% and 7.5%. Record manifold pressure.
 - e. Record CO reading (200 ppm maximum).
 - f. To prevent products of combustion from escaping, cover the test hole in the vent with aluminum adhesive tape.
16. Re-attach the plastic condensate plumbing.
 17. Re-attach regulator and test port caps, replace the lower front jacket cover.
 18. **IMPORTANT** – Remove the existing information decal attached to the front control panel and replace with the provided label showing the now converted fuel type. Align the decal carefully before allowing it to touch the surface, as it cannot be moved once contact is made.

IGNITION SEQUENCE

1. When the water heater is powered (120 volts) through the ON-Off control switch, the Hot Surface Ignition Control will reset and perform a self-check routine to verify no flame is present before the call-for-heat sequence begins. The Digital Temperature Control (thermostat) displays the actual water temperature in the tank.
2. If the actual water temperature inside the tank is below the programmed temperature setpoint differential of the digital temperature control, a call-for-heat is activated.
3. When a call-for-heat is received from the thermostat, the ignition control will perform a safety timing sequence and flame check. If all checks are successfully passed, the combustion blower is energized for a 15-second pre-purge period.
4. When the pre-purge period is complete, the hot surface igniter (HSI) is energized for a 40-second heat-up period, followed by the gas valve for the 4-second trial-for-ignition (TFI) period. The igniter remains energized throughout the TFI period.
5. The ignition control will monitor for flame through the HSI during the trial for ignition period. If a valid flame is detected the gas valve remains energized.
6. The thermostat and main burner flame signal are constantly monitored by the ignition control to assure that the system operates properly. The control will continuously monitor the flame during the heating period.
7. If the burner fails to light or the flame is not detected during the first TFI, the gas valve is de-energized. Following a purge period, the ignition control will make three TFI attempts before locking out.
8. If the flame signal is lost while the burner is operating, the ignition control will de-energize the gas valve. Following a purge period, the ignition control will make three TFI attempts before lockout. If flame is reestablished, normal operation resumes.
9. When the thermostat is satisfied and the demand for heat ends, the gas valve is de-energized.