

Installation, Operation & Maintenance Manual

CSX and CSXT

Instantaneous Steam Water Heater

Important: This manual contains information required for installation, operation and maintenance of this equipment. Read and follow the information in this manual and all other provided instructions, labels and markings before installing, operating or servicing this unit.

Installation and service must be performed by a qualified service installer, service agency or the gas supplier.



To the installer: After installation, these instructions must be given to the equipment user or left near the appliance.

Special instructions to the owner: Retain this manual for future reference. These instructions contain important information that will help you in maintaining and operating this appliance.

Hot Water Solutions

CSX and CSXT SERIES WATER HEATER

TABLE OF CONTENTS

- 1. Safety Considerations**
- 2. Product Descriptions**
- 3. Water Heater Installation**
 - 3.1 Codes
 - 3.2 Installation
 - 3.3 Electrical Requirements
 - 3.4 Water Inlet / Outlet Connections
 - 3.5 Relief Valve Piping
 - 3.6 Steam Connections
- 4. Description of Operation**
 - 4.1 Description of Operation: Sub-cooler
- 5. Startup Procedure**
 - 5.1 Pre-startup Inspection
 - 5.2 With All Product Valves Closed
 - 5.3 Operating Reminders
 - 5.4 Shut Down
- 6. Maintenance**
 - 6.1 Cleaning the Heat Exchanger
 - 6.2 Temperature Control Valve
 - 6.3 Relief Valves
 - 6.4 Condensate Y-strainers
- 7. Troubleshooting Suggestions**
- 8. Wiring**
 - 8.1 Standard CSX
 - 8.2 CSXT

CSX and CSXT SERIES WATER HEATER

1 SAFETY CONSIDERATIONS

WARNING: Do not use this appliance if any part has been under water. Immediately call a qualified service technician to inspect the unit and to replace any part of the control system, any gas controls and any other items affecting safe appliance operation and which has been under water. Failure to follow these instructions can cause property damage, personal injury, exposure to hazardous materials or death.

IMPORTANT SAFETY NOTE

It takes only 5 seconds of skin contact with 140 °F water to cause a second degree burn! You must protect against high water temperatures at all lavatories, tubs, showers and other points of hot water contact.

Accidental scalding from high water temperatures is a greater risk in some types of installations. Some examples are:

**HOMES FOR THE MENTALLY OR PHYSICALLY HANDICAPPED
HOSPITALS AND NURSING HOMES**

ELDER CARE FACILITIES AND REST HOMES

ORPHANAGES AND CHILD CARE FACILITIES

**OTHER INSTALLATIONS - WHERE RESPONSE TO CONTACT WITH HOT WATER
MAY BE SLOWER OR WHERE THE DANGER OF HOT WATER CONTACT IS GREATER**

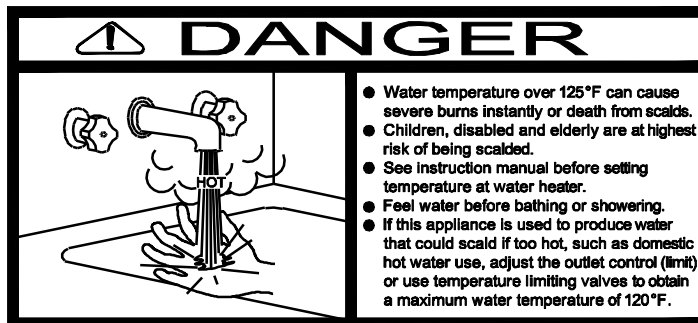

Thermostatically controlled mixing valves must be used in the design of the potable hot water system. Potable hot water should be tempered to no more than 110°F when used for bathing or other personal uses.

Good engineering practice mandates the use of thermostatically controlled mixing valves set at 120°F or less to keep the delivered water temperature below scalding temperatures.

CSX and CSXT SERIES WATER HEATER

2 PRODUCT DESCRIPTIONS

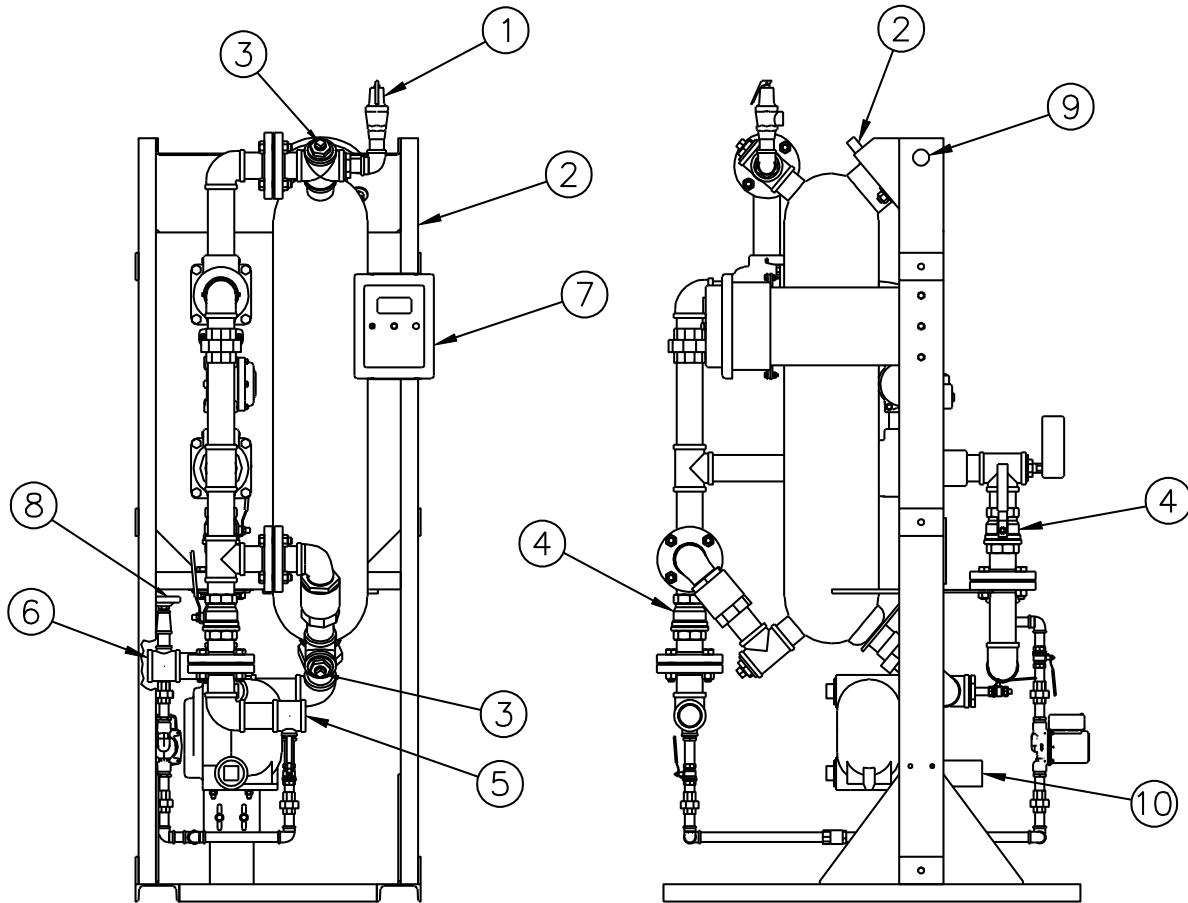

Typical Construction for CSX

- | | |
|-------------------------------------|--|
| 1. ASME-rated pressure relief valve | 7. Electrical connection/control cabinet |
| 2. Steam connection | 8. Temperature gauge |
| 3. Clean in place port | 9. Lifting points (2 points) |
| 4. Water isolation valve | 10. Condensate return connection |
| 5. Cold water inlet | 11. Optional Intra-skid circulator (<i>see next page</i>) |
| 6. Hot water outlet | 12. Optional Sub-cooling heat exchanger (<i>see next page</i>) |

CSX and CSXT SERIES WATER HEATER

VIEW FOR CSX SUB-COOLER & INTRA-SKID OPTIONS

NOTE: Heater may be equipped with both options.

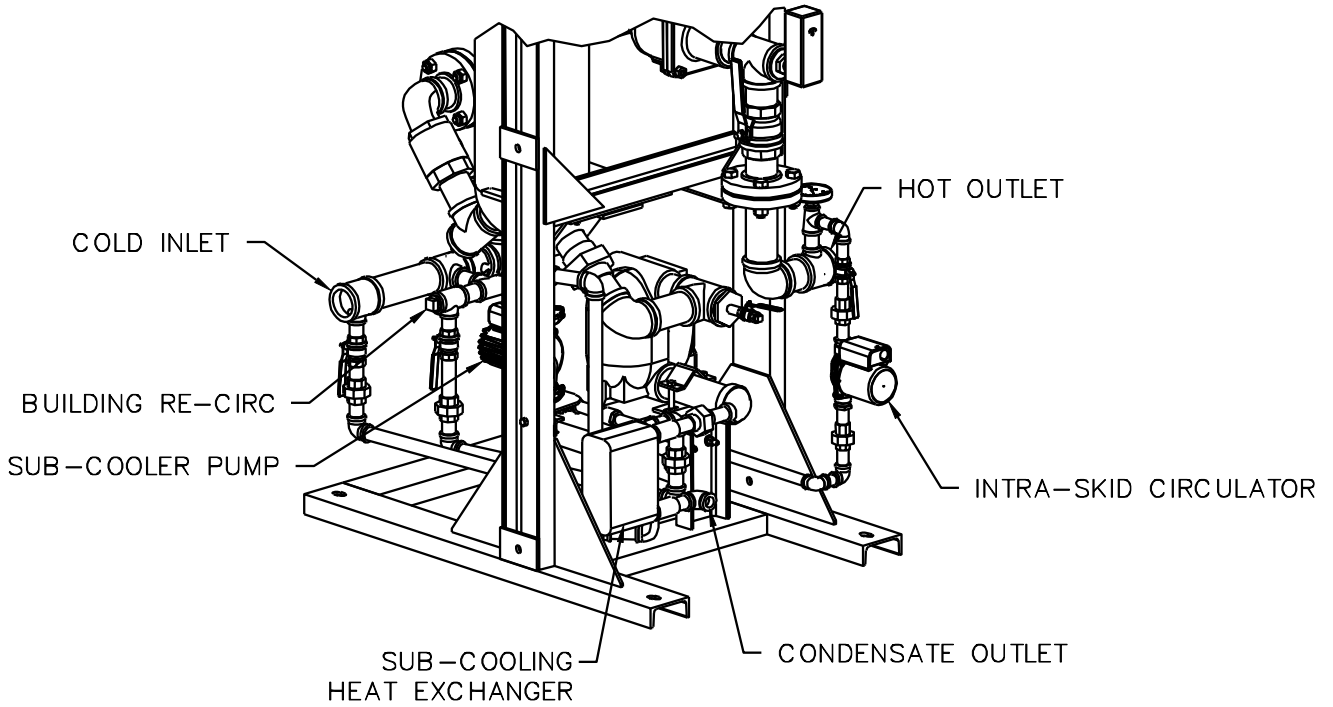

REAR VIEW OF HEATER SHOWING SUB-COOLER
AND INTRA-SKID OPTIONS

11 12

CSX and CSXT SERIES WATER HEATER

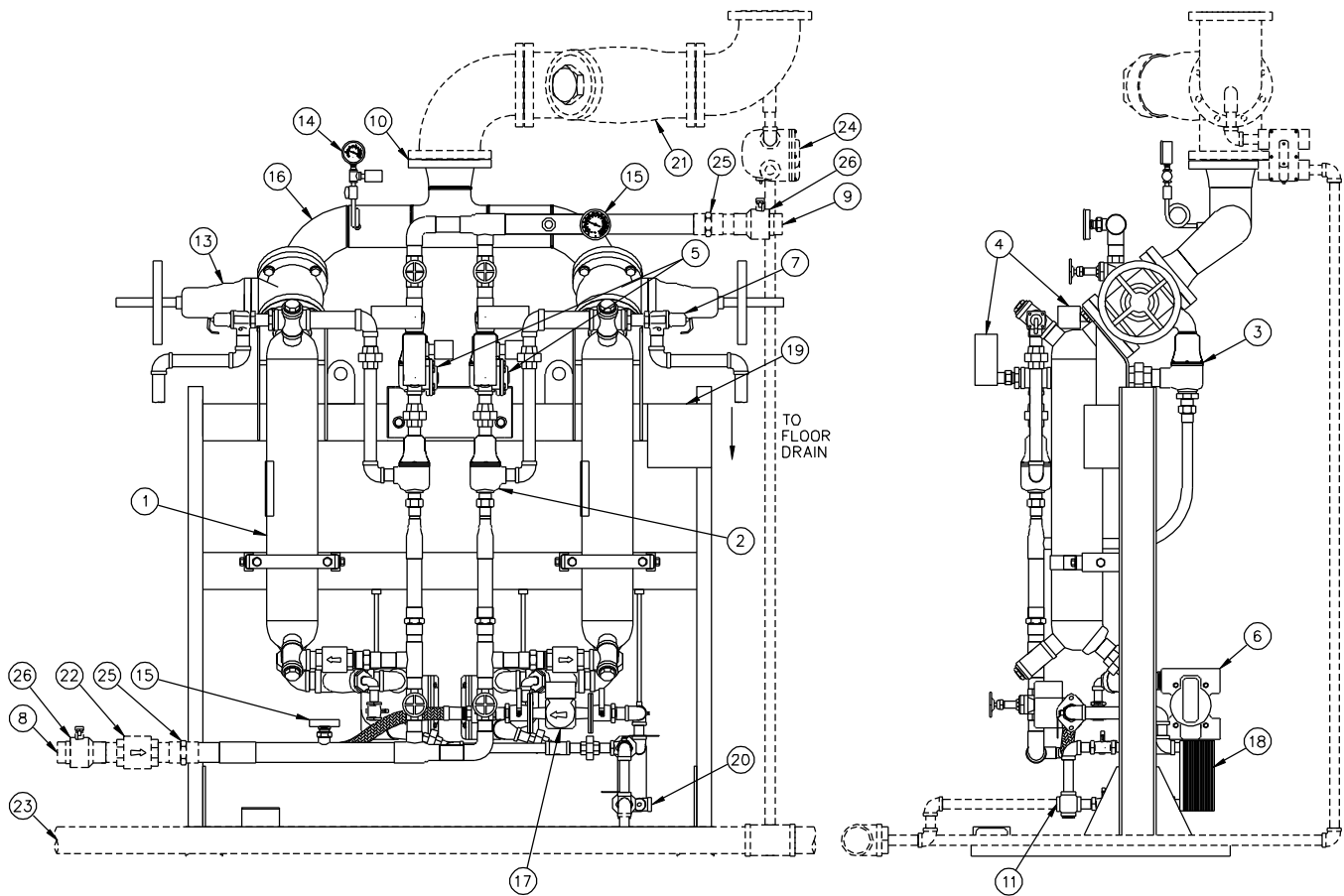

Typical Construction for CSXT

- | | | |
|---|---|---|
| <ul style="list-style-type: none"> 1. Heat exchanger(s) 2. Primary temperature control valve(s) 3. Secondary temperature control valve(s) 4. Temperature limiting device 5. Solenoid shutoff valve(s) 6. Steam trap(s) 7. Pressure relief valve (Plumb to floor drain) 8. Potable water inlet 9. Potable water outlet 10. Steam inlet | <ul style="list-style-type: none"> 11. Condensate connection 12. Steam regulating valve * 13. Steam shutoff valve(s) * 14. Steam pressure gauge * 15. Temperature gauges * 16. Steam header * 17. Return circulation pump * 18. Subcooling heat exchanger * 19. Instrumentation wiring junction box * 20. Circulation return connection * | <ul style="list-style-type: none"> 21. Y-strainer ** 22. Check valve ** 23. Condensate return line ** 24. Steam supply line condensate trap ** 25. Unions ** 26. Isolation valves ** <p style="margin-top: 10px;">* Optional
** Not supplied by PVI (shown with dashed lines)</p> |
|---|---|---|

WARNING: Improper installation, adjustment, alteration, service or maintenance can cause property damage, personal injury, exposure to hazardous materials or death. Refer to the information contained in this manual for installation, operation and maintenance of this equipment. Installation and service must be performed by a qualified installer or service agency, who must read and follow the information in this manual and all other provided instructions, labels and markings before installing, operating, servicing or removing this appliance.

CSX and CSXT SERIES WATER HEATER

3 WATER HEATER INSTALLATION

3.1 CODES

The equipment must be installed in accordance with the instructions in this manual, appliance markings and supplemental instructions and in compliance with those installation regulations in force in the local area where the installation is to be made. These shall be carefully followed in all cases. Authorities having jurisdiction must be consulted before installation is made. In the absence of such regulations, the installation must be in accordance with the instructions in this manual, appliance marking and supplemental instructions and in compliance with the latest edition of the applicable state mechanical and plumbing code.

3.2 INSTALLATION

CHECKING EQUIPMENT BEFORE YOU INSTALL – Inspect the unit completely upon receipt from the freight carrier before signing the bill of lading. Inspect the appliance and all accompanying parts for signs of impact or mishandling. Verify the total number of pieces shown on packing slips with those actually received. Contact the freight carrier immediately if any damage or shortage is detected.

WARRANTY – The Factory Warranty does not apply to the improper installation or operation of the equipment. Experience has shown that improper installation or system design, rather than faulty equipment, is the cause of most operating problems. The warranty also excludes damage to the equipment caused by corrosive chemicals present in the mechanical room, steam or water. (See Warranty for complete details.)

1. Confirm that the system utilities are adequate to meet the heater requirements on the decal.
2. These units are suitable for indoor installation only.
3. The appliance must be placed on a level floor.
4. Do not attempt to move or lift heater by the plumbing connections or heat exchanger. Lift only by the skid using industry standard safe rigging methods.
5. Locate the unit so that if water connections should leak, water damage will not occur. When such locations cannot be avoided, it is recommended that a suitable drain pan, adequately drained, be installed under the unit. Water damage is not covered by the manufacturer's warranty.
6. Units and associated electrical components and electrical connections, must be installed so they are protected from water (dripping, spraying, rain, etc.) during appliance operation and service.
7. It is recommended that at least 18" be provided on all sides and above the appliance for service and inspection. Optional equipment may increase the clearance requirements. Allow sufficient space for installing and servicing connections such as water, steam, and condensate, relief valve to drain plumbing, electrical, pump and other auxiliary equipment.
8. In hard water areas, potable water treatment should be used to reduce introduction of minerals into the system. Minerals in the water can collect on the tubes and heat-exchanger surfaces reducing the life of the product. Heat exchanger failure due to scale accumulation is not covered by the product warranty.

IMPORTANT: The CSX is not recommended for use where water chloride levels exceed 70 ppm. Chloride levels above 70 ppm can result in unwarranted heat exchanger damage.

3.3 ELECTRICAL REQUIREMENTS

This appliance is wired for 120-volt service. The appliance, when installed, must be electrically grounded in accordance with the requirements of the authority having jurisdiction or in the absence of such requirements, with the latest edition of the National Electrical Code ANSI/NFPA No. 70. When the unit is installed in Canada, it must conform to the CAE C22.1, Canadian Electrical Code and/or Local Electrical Codes.

1. Supply 15 amp, 120V service to each water heater. Separate electrical circuits are recommended for multiple appliance installations.
2. All wiring between the unit and field installed devices must be made with type T copper wire of proper size for the appliance load. Damage resulting from use of aluminum wiring will be unwarranted.
3. On CSXT units, line voltage (120V, single phase) must be connected separately to both solenoid valve junction box connection points and to the recirculation pump (if supplied).
4. Line voltage wire exterior to the appliance must be enclosed in approved conduit or approved metal clad cable.
5. Instrumentation wiring connections (if equipped) are all made in the junction box located on the right side of the appliance. Connect to the labeled terminal blocks according to the instrumentation wiring diagram. Operation of the pressure transducer depends on a 12-30 VDC power supply being connected to the specified terminals. All RTD probes are of the 3-wire type and to achieve optimum accuracy, all three wires must be connected to a RTD meter or transmitter with 3-wire input connections (such as an Omega #TX92A-3).

3.4 WATER INLET / OUTLET CONNECTIONS

CSX and CSXT SERIES WATER HEATER

IMPORTANT: Before connecting the heater, steam, water and condensate lines must be supported so the water heater is not supporting any piping weight. If there is weight put on the heat exchanger connections, it could lead to unwarranted stress-induced corrosion of the heat exchanger or mechanical damage of the system.

1. Connect the water inlet and outlet to the potable system. Use backup wrenches on all screwed pipe connections to prevent damage to the heater plumbing. Piping and components connected to the water heater must be suitable for potable water, for the water temperatures they will experience and for their application.
2. For ease of service, install unions and shutoff valves on inlet and outlet piping to the unit.
3. The heater must be connected to a building recirculation system with a pump capable of maintaining a minimum flow rate of 4 gpm through the water heater at all times. If building recirculation is not available, an intra-skid circulator pump should be added as an option for maintaining minimum flow requirements. Connect the building hot water recirculation return line directly to the cold water inlet of the heater. **NOTE:** if the condensate subcooling option is purchased from the factory, a dedicated connection is provided for the building hot water recirculation return line.
4. Fix any system leaks. DO NOT use petroleum based stop-leak products. All system leaks must be repaired.
5. After plumbing the unit and checking for leaks, the heat exchanger and steam and hot water piping should be insulated. Insulation will reduce wasteful heat loss and will help protect operators from contacting hot surfaces.

WARNING: Insulate or guard all surfaces containing steam and hot water. Uninsulated or unguarded surfaces containing steam or hot water can be hot enough to cause severe burns instantly, if contacted. Failure to insulate or guard all surfaces containing steam or hot water can result in property damage, personal injury, or death.

3.5 RELIEF VALVE PIPING

CSX water heaters are supplied with pressure relief valves for each heat exchanger sized in accordance with ANSI/ASME Boiler and Pressure Vessel Code, Section IV. The relief valve(s) must be threaded directly into the dedicated relief valve fitting located near the top of the heat exchangers and the relief valve discharge must be plumbed to an appropriate floor drain. The discharge line must allow complete drainage of the valve and line.

The water heater must not be operated without a correctly installed, properly sized and properly operating relief valve. If a replacement relief valve is required, it must be of the automatic reset type pressure relief valve complying with the ANSI/ASME Boiler and Pressure Vessel Code, Section IV, must not be less than the hourly Btu input rating of the water heater as stated on the information decal located on or adjacent the Heat Exchanger and must not have a relieving pressure exceeding the 150 psi maximum working pressure of the water heater.

A relief valve that discharges periodically may result from the thermal expansion of heated water when restricted by a backflow preventer or check valve installed in the cold water supply. A means to control thermal expansion must be provided by a qualified plumbing professional. Do not plug the relief valve.

WARNING: Do not install a reducing coupling, valve or other restriction between the relief valve discharge and a suitable floor drain. Such restriction could prevent the valve from fully relieving if the pressure settings are exceeded, which could result in property damage, personal injury or death.

WARNING: The relief valve discharge must be piped to a suitable floor drain to avoid exposure to hot discharge water during relief valve operation. Exposure to hot discharge water can cause water damage and/or burns resulting in property damage, personal injury or death.

3.6 STEAM CONNECTIONS

IMPORTANT: Before connecting the heater, steam, water and condensate lines must be supported so the water heater is not supporting any piping weight. If there is weight put on the heat exchanger connections, it could lead to unwarranted stress-induced corrosion of the heat exchanger or mechanical damage of the system.

1. All steam and water supply lines should be flushed before connecting the unit. Failure to flush lines could cause components of unit to malfunction.
2. Steam supplied to the heater must not exceed 15 psi. If the steam supply pressure exceeds 15 psi, a steam regulating valve must be used to limit steam supply pressure to 15 psi.

CSX and CSXT SERIES WATER HEATER

WARNING: Steam supply to the heat exchanger must be constant and less than or equal to 15 psi. An unregulated steam supply or steam supply in excess of 15 psi could cause loss of temperature control and failure of heater components that may result in property damage, personal injury or death.

3. In order to achieve rated hot water output, the capacity of the steam supply system must exceed the heater requirements as stated on the heater decal.
4. A y-strainer with blow-down valve with piping to a suitable drain and a steam trap with piping to a suitable drain or condensate receiver plumbing must be installed in the steam supply piping near the appliance and upstream from the steam pressure regulating valve, if equipped.
5. A steam pressure gauge must be installed in the steam piping near the appliance inlet and downstream from the steam pressure regulating valve, if equipped.
6. Install the steam header, if supplied, using the supplied gaskets, grade 5 bolts, nuts and washers. Orient the steam gauge vertically.
7. Connect the main steam trap(s) to the condensate return. The trap(s) must be located below the elevation of the condensate drain connection on the heat exchanger.
8. Connect steam and condensate connections to the building system plumbing. The recommended methods of condensate distribution are:
 - a. Plumb to a condensate receiver and pump or vacuum return to the condensate return header.
 - b. Plumb to a pneumatic/electric actuated condensate pump trap for return to the condensate return header.
 - c. Plumb to drain – (Requires additional make-up water at steam supply boiler).

NOTE: In some applications where a heater is equipped with a sub-cooler, and condensate is plumbed to a drain, it may be necessary to add a restriction to the flow of condensate from the outlet of the sub-cooler.

Add an adjustable orifice such as a gate valve to the condensate sub-cooler outlet so that the resistance of the orifice will slow down the flow of condensate through the heat exchanger and allow sufficient time for heat to transfer and cool the condensate properly.

IMPORTANT: Inadequate drainage of condensate from the water heater will adversely affect heat transfer, will limit water heater performance and may cause unwarranted damage to the water heater. After all the connections are made it is a good practice to tighten all unions and check the electrical connections.

9. Insulate or guard all surfaces and pipes containing steam and/or hot water.

WARNING: Insulate or guard all surfaces containing steam and/or hot water. Uninsulated or unguarded surfaces containing steam or hot water can be hot enough to cause severe burns instantly, if contacted. Failure to insulate or guard all surfaces containing steam or hot water can result in property damage, personal injury, or death.

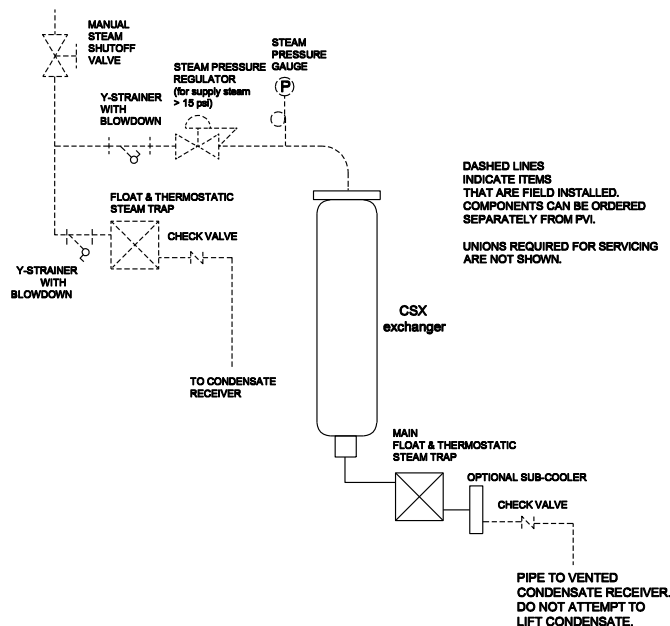

Typical CSX Steam Piping Layout

CSX and CSXT SERIES WATER HEATER

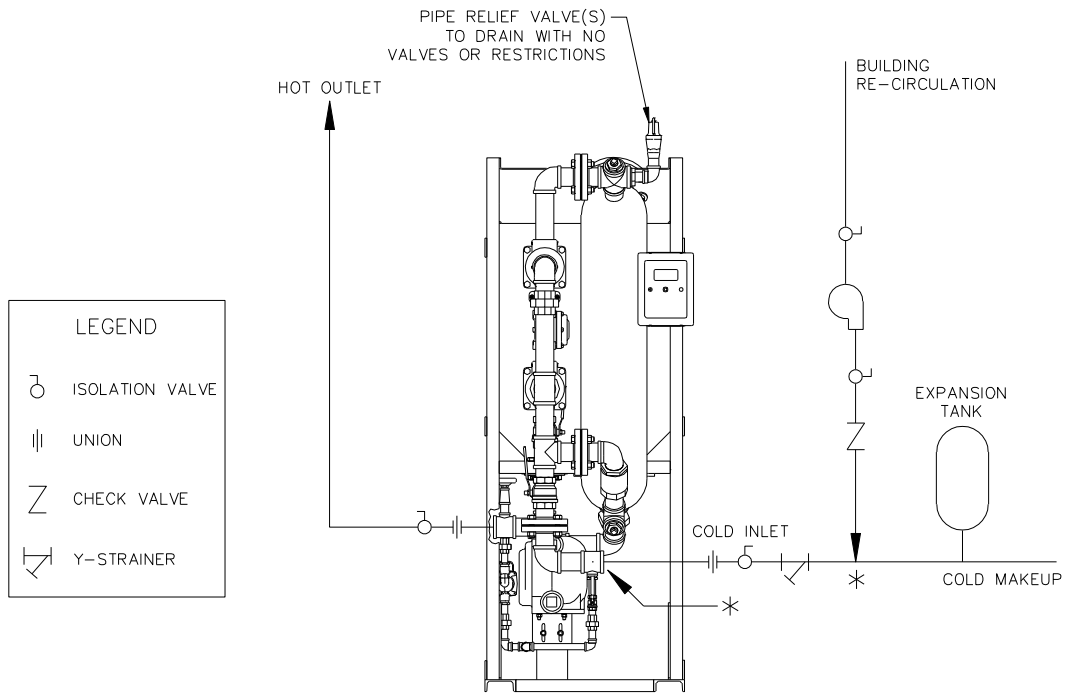

* Dedicated connection for building recirculation on heaters with optional sub-cooler. Connect recirculation to this point instead of cold inlet if sub-cooler is ordered.

Typical Single CSX Plumbing Layout

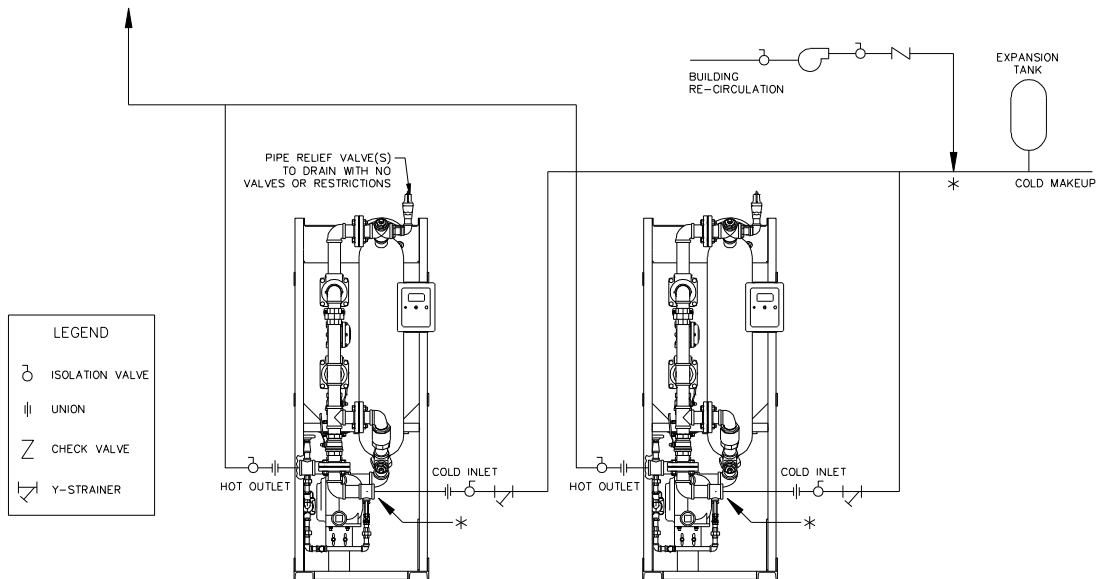

* Dedicated connection for building recirculation on heaters with optional sub-cooler. Connect recirculation to this point instead of cold inlet if sub-cooler is ordered.

Typical Dual CSX Plumbing Layout (Requires Balanced Reverse Return Piping)

4 DESCRIPTION OF OPERATION

CSX and CSXT SERIES WATER HEATER

When there is no hot water demand, the steam and water sides of the heat exchangers in this water heating system reach thermal equilibrium, so it is constantly ready to provide hot water. If the available supply steam pressure is more than 15 psi, a steam regulating valve (available option) must be used to reduce the steam pressure. A pressure-sensing pilot on this steam regulating valve forces the steam valve closed as pressure reaches and is maintained at 15 psi. As hot water demand is placed on the appliance, cold water entering the heat exchanger condenses steam causing pressure in the steam inlet piping to drop. This lower pressure causes additional steam to enter the heat exchanger to meet the heating load. When hot water demand diminishes, steam pressure in the heat exchanger again increases to match the supply steam pressure.

When hot water demand is initiated, cold water enters the cold inlet port of the temperature control valve(s). Cold water flows into the valve body, where it is blended with hot water from the heat exchanger. If the blended water temperature at the valve outlet increases or decreases from the specified temperature, the internal ports reposition to change the amount of cold and hot water blended to again reach the specified blended water temperature. When demand ceases, the temperature control valve moves to seal the hot port. The water heater utilizes a two valve step reduction system to improve temperature control and response to changes in demand. In order for these valves to properly respond to changing hot water demand and to maintain proper temperature control, a constant flow of at least 4 gallon per minute is required. This flow is provided by the intra-skid circulator pump included with all 140°F and 160°F heaters. The 120°F unit does not have the 4 gpm minimum requirement.

Two temperature limiting devices monitor the temperature downstream of each temperature control valve. If the valve does not hold the temperature close to its setpoint, the limiting devices will shut the solenoid valve blocking flow of heated water to the outlet.

4.1 Description of Operation: Sub-cooler

Some heaters are equipped with an optional sub-cooler. The sub-cooler option consists of a plate type heat exchanger in the condensate line and a dedicated pump to circulate domestic water through the cold side of the exchanger. This option reduces the 200°F plus temperature of condensate exiting the trap(s). This reduces energy lost in the condensate lines and enables the heater to be installed into a vacuum condensate return system where condensate must be below a certain design temperature. The condensate that is produced during heater operation flows from the steam trap and through the sub-cooling heat exchanger and then enters into the condensate receiver or drain. The sub-cooler circulator flows domestic water from the cold inlet of the water heater to the sub-cooling heat exchanger and then back to the cold inlet plumbing where this heated water is blended with the cold water flowing into the heater so that some of the heat from the condensate is returned to the water heater. A temperature limiting thermostat monitors the temperature of this blended water and if the temperature at this point becomes higher than the set point, the thermostat will shut off the circulator pump. This protects the water heater from overheating if the steam trap were to fail and allow steam to flow into the sub-cooling heat exchanger.

5 STARTUP PROCEDURE

5.1 Pre-startup Inspection:

- Confirm the water supply pressure does not exceed the psi rating of the relief valve and heat exchanger.
- Confirm the main steam stop valve upstream of the water heater is closed. If the heater is installed without a steam regulating valve, steam supply pressure must never exceed 15 psi.
- Water supply pressure must be more than 30 psi flow pressure at all times. Water pressure below steam pressure will result in flashing inside the heat exchanger and, in the event of a heat exchanger tube leak, could allow contaminated steam to enter the potable water.

WARNING: To avoid possible contamination of potable water in the event of a heat exchanger tube leak, water pressure in the heat exchanger must always be maintained above the supply steam pressure. Potable water contamination resulting from failure to maintain water pressure in the heat exchanger above the supply steam pressure can cause personal injury, exposure to hazardous materials or death.

- Contact factory if water pressure may occur lower than the steam supply pressure.
- Check all pipe fittings.
- A steam pressure gauge must be installed in the steam piping entering the heater. If there is a steam regulating valve, the pressure gauge must be installed in the downstream tap or downstream piping.

5.2 With Product Inlet and Outlet Valves Closed, Proceed as Follows:

1. Check the set-point of the temperature limiting device near the hot water outlet.

CSX and CSXT SERIES WATER HEATER

- The limit device located downstream of the secondary thermostatic mixing valve and near the hot water outlet must be set 10°F above the outlet water temperature element installed in the heater (i.e. if the outlet water temperature element is 120°F, the downstream limit set-point is 130°F).
- The limit device located between the primary and secondary thermostatic mixing valves is not adjustable and is set at 190°F, the upstream limit closes the high limit solenoid shutoff valve at 190°F)

2. Crack open the steam strainer blow-down valve.

3. Slowly open the water supply valve to the heater. Check for water leaks on waterside piping. Crack open the potable water outlet valve downstream of the heater to vent air from exchanger and piping. Momentarily open the relief valve to purge air out of the system. It may be necessary to open a hot water faucet downstream in the system. Continue venting air from the heater and piping, until a consistent flow of water is demonstrated.

CAUTION: If circulation pumps are present in the waterside plumbing of the heater, do not switch power on to the unit before introducing water into the heater plumbing. Allowing the pumps to run dry for long periods will cause damage to the pumps and is not covered by the warranty.

4. Switch on power to unit to activate the solenoid valves and thermostats. The solenoid valve(s) should open.

CAUTION: Do not supply steam to a heater until a consistent flow of water is demonstrated.

5. Crack open the steam supply to the heater and allow condensate and air to be vented through the steam inlet strainer blow-down and steam supply valves. Then close the inlet strainer blow down valve.

6. Slowly and fully open the main steam shutoff valve(s). Confirm steam pressure entering the heat exchanger(s) is 15 psi or less. Open the blow down valve at the bottom of the heat exchanger until a steady flow of steam is observed, then close the blow down valve.

7. Adjust pressure pilot (if equipped) so that the pressure downstream of the valve is 15 psi or less. (Refer to the steam valve literature for adjustment instructions.)

8. Observe steam traps for operation. Traps are self-priming and should require no further adjustment.

9. Check the pressure in the condensate return line. The ability to lift condensate via steam pressure cannot always be assured. Generally ½ psi steam pressure is required for every foot in height that the condensate is to be lifted. Lifting condensate is not recommended, but if lifted, a check valve must be installed immediately after the heater condensate outlet in condensate return line. Use of a pump or vacuum type condensate return system is recommended.

IMPORTANT: Special attention should be paid to noise and leaks. Non-destructive water hammer (noise) as well as noise generated from the expansion of steam is expected during startup. Extraordinary noise generation or leaking piping is reason to shut down the steam supply to the unit.

5.3 Operating Reminders

In order to achieve maximum performance from the heat exchanger, the following must be strictly followed:

- Pressures and temperatures must not exceed limits on product decal.
- Heat exchangers should be free of any debris existing in the water.
- Prevent evaporation of fluid on the shell side. Steam or vapor should only flow through the tubes.
- The system should be designed to prevent the heat exchanger from encountering pressure shocks.
- Prevent rapid temperature increases in the heat exchangers. This would include installation of expansion tanks and safety valves into the system.
- Prevent water in heat exchanger and piping from dropping below their freezing point.
- A minimum of 4 gpm recirculation flow through the heater is required at all times (for 140° and 160° heaters; this flow is provided by the intra-skid circulator pump).

5.4 Shut Down

1. Valve off the supply of steam to the heater.
2. Allow a flow of potable water until it runs cold. Then shut off isolation valve at inlet of heater and then outlet.
3. Then disconnect electrical power.

6 MAINTENANCE

A preventative maintenance program should be established to assure a long, trouble-free life for the water heater.

WARNING: High Voltage Shock Potential - Turn off all electrical service to the appliance prior to opening water or steam piping and when accessing limit controls, high limit controls, solenoid valves or other high voltage components and wiring. After access, check all connections, close all covers and otherwise secure all electrical wiring and components before restoring electrical service to the appliance. Wires and terminals

CSX and CSXT SERIES WATER HEATER

carry High Voltage (120V). If the electrical service is not turned off and terminals, exposed wires or conducting metals are exposed, a dangerous shock causing personal injury or death could occur.

6.1 Cleaning the Heat Exchanger

The heat exchanger has inspection plugs (at the hot water outlet and cold water inlet of the heat exchanger) suitable for inspection and cleaning use. The heat exchanger should be isolated from steam and water pressure, allowed to cool and inspected for scale buildup through these openings.

A scale of lime will normally form during operation and will accumulate inside the heat exchanger shell. Lime is formed from naturally occurring mineral compounds in the water, which precipitate out during heating cycles. Some water supplies contain more of these compounds than others and scale buildup will occur more rapidly. Other factors affecting the rate of scale buildup are the amount of hot water used and the temperature of the water. The more hot water used, the more fresh water containing scale-forming compounds is brought into the tank. As the temperature of water increases, the rate of scale deposition will increase.

The frequency of inspections will be determined by the rate of scale buildup. Until the appropriate inspection and cleaning interval is established, it is recommended that the heat exchanger be inspected and internally cleaned every six months or more frequently if higher scaling conditions are inspected.

Debris deposited in the heat exchanger will result in an increase in pressure drop, lower temperature difference on the waterside or a high exit temperature on the steam side. Flushing can be done without removal of the heat exchanger from the system.

The heat exchanger is cleaned by flushing the units with fluids that do not react with stainless steel. A food grade acid detergent or descaler is recommended. The following fluids are prohibited for use as a flushing agent:

- Hydrochloric acid up to 0.1% concentration
- Solutions which contain metallic chloride
- Chlorides (MgCl₂, NaCl between 0.01 – 1%, CuCl up to 1%, CaCl₂ from 5% to saturation, KCl)
- Any fluid which would deposit alkaline residue or phosphorous

The cleaning solutions are available at businesses carrying chemical cleaning agents for heat exchangers or tubing and piping applications. As a guideline to purchasing cleaning solutions, check for the following product properties:

- Compatibility with 316L stainless steel
- Compatibility with brass and copper.
- Accepted for use in food processing industries
- Removes scale, slag, tarnishes, and hard water deposits
- Easily rinsed out of the systems
- No objectionable or corrosive fumes

When cleaning the heat exchanger, also inspect the plumbing to the temperature control valve for scale build-up. If necessary, de-scale those hot water surfaces.

6.2 Temperature Control Valve

The temperature control valves are factory set and are not adjustable. They should be inspected and internally cleaned every six months or more frequently if needed. Replacement of the o-ring seals is recommended when the valve body is opened to access the thermostatic element for inspection or replacement. The thermostatic element should be replaced if variation in controlled temperature occurs. The frequency of element replacement will depend on operating conditions.

The thermostatic elements utilize wax activated diaphragm and plug construction. A thermostatic element can be checked by immersing it in an agitated bath of water. Never use oil for checking the element. At 10°F to 13°F above the nominal setting, the bypass port B should be closed.

Replacement elements may be ordered from PVI. The element part number and nominal temperature setting are stamped on the flange of the element. If these are not known, provide PVI the complete model number and serial number on the valve nameplate. O-ring seals should be replaced whenever replacing elements. When installing or reinstalling seals, always lubricate them with light food grade plumbing grease to make installing of the element easier, and to prevent leakage from the housing.

CSX and CSXT SERIES WATER HEATER

6.3 Relief Valves

Relief valves should be manually operated at least once a year and if it fails to freely discharge water or fails to reseal following testing, it must be replaced with a like relief valve (see installation section for description).

6.4 Condensate Y-strainers (if installed)

Periodically blow-down the valves on the condensate y-strainers. If necessary, shutdown heater, remove and clean the mesh inside the strainer.

WARNING: Use caution and proper personal protection when opening blow-down valves. Discharge from the blow-down valves on the condensate y-strainers is extremely hot and can flash to steam. Failure to use caution and proper personal protection when opening blow-down valves can result in property damage, instant scalding, other personal injury or death.

CSX and CSXT SERIES WATER HEATER

7 TROUBLESHOOTING SUGGESTIONS

Problem:

1. Steam delivery pressure to heat exchanger is low or drops off:

- a. **Cause:** Low inlet pressure.
Solution: Fully open valve. Unclog strainer. Check for low boiler output or upstream blockage and make necessary corrections.
- b. **Cause:** Steam regulating valve pilot adjustment altered.
Solution: Readjust to desired operating condition.
- c. **Cause:** Steam regulating valve pilot range incorrect.
Solution: Check nameplate for operating range of pilot. Change pilots if desired operating range is beyond that on existing pilot.
- d. **Cause:** Steam regulating valve undersized.
Solution: Check valve capacity against the load. If insufficient, increase valve trim or valve size. Refer to the valve manual for instructions.
- e. **Cause:** Piping flow restricted.
Solution: Calculate the flow velocity and expected friction loss. If excessive, larger inlet and outlet piping are necessary.
- f. **Cause:** Bleed orifice missing from steam regulating valve.
Solution: Bleed orifice should be in the downstream fitting of the steam valve. Install a new bleed orifice. If a straight fitting was installed in place of the bleed orifice or it is worn, the pilot signal may not fully open the main valve.
- g. **Cause:** Steam regulating valve pilot lines blocked.
Solution: Remove the line to the main valve and the downstream feedback line. If they are not clear, replace.
- h. **Cause:** Steam regulating valve pilot malfunction.
Solution: Refer to the valve manual for instructions on pilot valve repair.
- i. **Cause:** Steam regulating valve malfunction.
Solution: Refer to the valve manual for instructions on main valve repair.

Problem:

2. Steam delivery pressure is high or overrides:

- a. **Cause:** Open valve on steam regulating valve by-pass line.
Solution: Close the valve
- b. **Cause:** Steam regulating valve pilot adjustment altered.
Solution: Readjust to desired operating condition.
- c. **Cause:** Steam regulating valve pilot lines or bleed orifice blocked.
Solution: Remove, check and replace as required.
- d. **Cause:** Steam regulating valve feedback control line plugged.
Solution: Remove and clean.
- e. **Cause:** Steam regulating valve oversized.
Solution: Check valve capacity against the load. If excessive, install smaller trim or valve. Refer to the valve manual for instructions.
- f. **Cause:** Steam regulating valve pilot malfunction.
Solution: Refer to the valve manual for instructions on pilot valve repair.
- g. **Cause:** Steam regulating valve malfunction.
Solution: Refer to the valve manual for instructions on main valve repair.

CSX and CSXT SERIES WATER HEATER

Problem:

3. Steam delivery pressure erratic:

- a. **Cause:** Pressure drop limits exceeded. Recommended maximum single stage reduction is 100 psi (6.9 bar).
Solution: Reduce the pressure drop. If drop remains above 100 psi (6.9 bar), consult representative or factory.
- b. **Cause:** Strainer clogged.
Solution: Clean strainer.
- c. **Cause:** Steam regulating valve oversized.
Solution: Check valve capacity against load. If excessive, install smaller trim or valve. Refer to the valve manual for instructions.
- d. **Cause:** Steam regulating valve pilot lines or bleed orifice blocked.
Solution: Remove, check and replace as required.
- e. **Cause:** Sensing line poorly located. The feedback signal will be inconsistent if line is in a turbulent area.
Solution: Relocate line to a non-turbulent area.
- f. **Cause:** Steam regulating valve pilot malfunction.
Solution: Refer to the valve manual for instructions on pilot valve repair.
- g. **Cause:** Steam regulating valve malfunction.
Solution: Refer to the valve manual for instructions on main valve repair.

Problem:

4. Outlet water temperature not constant.

- a. **Cause:** Recirculation inadequate.
Solution: In certain conditions (usually at very low flow), inadequate system water recirculation can lead to unstable outlet water temperature. Confirm the recirculation pump is operating properly and is providing a minimum of 4 gpm flow through the heater at all times. Also confirm the heater hot water isolation valve and any other valves in the recirculation line are open.
- b. **Cause:** Failed temperature control valve.
Solution: Disassemble valve and replace temperature element and gaskets per valve manufacturer's recommendations.
- c. **Cause:** Unstable, low or high steam pressure
Solution: See causes and solutions to Problem 1, 2 or 3 above.

Problem:

5. Outlet water temperature below setpoint.

- a. **Cause:** Excessive flow rate.
Solution: Water flow rate through heat exchanger surpasses its capacity. Check flow rate and compare with heater decal.
- b. **Cause:** Excessive scale in heat exchanger.
Solution: Scale on heating surfaces impedes heat transfer. Inspect heat exchanger coil and schedule cleaning.
- c. **Cause:** Failed temperature control valve.
Solution: Disassemble valve and replace temperature element and gaskets.
- d. **Cause:** Heater hot water isolation valve closed.
Solution: Fully open the heater hot water isolation valve.
- e. **Cause:** Solenoid valve closed.
Solution: Indicated by low water temperature and lowered flow rate. Check if thermostats are open. If so, then an over temperature condition occurred. Shutdown unit and disassemble and inspect temperature control valves. If not, then solenoid valve has failed. Replace.
- f. **Cause:** Power failure.
Solution: This closes the solenoid valve also causing loss of hot water pressure. Correct source of power loss.
- g. **Cause:** Low steam delivery pressure
Solution: See steam valve section above.
- h. **Cause:** Steam trap not operating properly.
Solution: Confirm that trap is backing up condensate in heat exchanger. The heater will sub cool at high flow rates, but at low flow rates the condensate temperature should be over 200°F.
- i. **Cause:** Failed heat exchanger.
Solution: If the heat exchanger fails in such a way that potable water flows into the steam system, flooding the heat exchanger and trap would impede heat transfer. Such a failure would require heat exchanger replacement.

CSX and CSXT SERIES WATER HEATER

- j. **Cause:** The high limit shutoff solenoid valve closed
Solution: If the high limit shutoff solenoid valve is energized, but is not open, service or replace the valve.
- k. **Cause:** One of the temperature limiting devices is tripped.
Solution: Confirm the limit device located downstream of the secondary thermostatic mixing valve is set 10°F above the outlet water temperature element installed in the heater (i.e. if the outlet water temperature element is 120°F, the adjustable limit set-point is 130°F). The limit device located between the primary and secondary thermostatic mixing valve is fixed at 40°F above the outlet water temperature element installed in the heater. If the adjustment is proper, but still tripped, confirm all other causes in this section are confirmed. If the other causes are confirmed and a temperature limit device is still tripped, replace the tripped device.
- l. **Cause:** Condensate flow restricted.
Solution: Check the condensate strainers for clogged condition. Check for restrictions or excessive lift in the condensate return system.

Problem:

6. Low Outlet Water Pressure.

- a. **Cause:** Scale build-up in heat exchanger.
Solution: Schedule cleaning of heat exchanger.
- b. **Cause:** Solenoid valve closed.
Solution: Check if thermostats are open. If so, then an over temperature condition occurred. Shutdown unit and disassemble and inspect temperature control valves. Check if optional PGM system has tripped. If neither, then solenoid valve has failed. Replace.
- c. **Cause:** Power loss.
Solution: When there is no power to the unit, the high limit shut-off solenoid valve is closed.

Problem:

7. Optional sub-cooler not working.

- a. **Cause:** Faulty circulating pump.
Solution: Repair or replace pump.
- b. **Cause:** Valves in circulating pump plumbing are closed.
Solution: Open valves. Confirm that check valve is operating properly.
- c. **Cause:** Mixed inlet thermostat has tripped and has shut off the circulating pump.
Solution: Check that steam trap is operating properly and repair or replace trap if necessary. Once the mixed inlet thermostat has tripped, the pump will be locked out and it will be necessary to reset the pump circuit by turning the main heater power switch off and then back on.

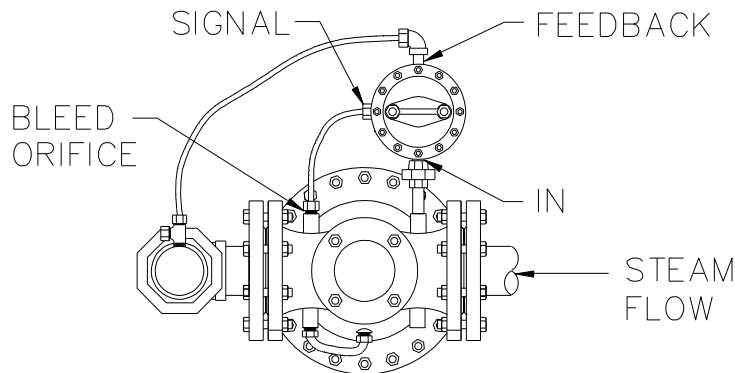

TOP VIEW OF OPTIONAL STEAM
PRESSURE REGULATING VALVE
WITH PILOT LINE

CSX and CSXT SERIES WATER HEATER

8 WIRING

8.1 CSX (dashed lines represent optional equipment)

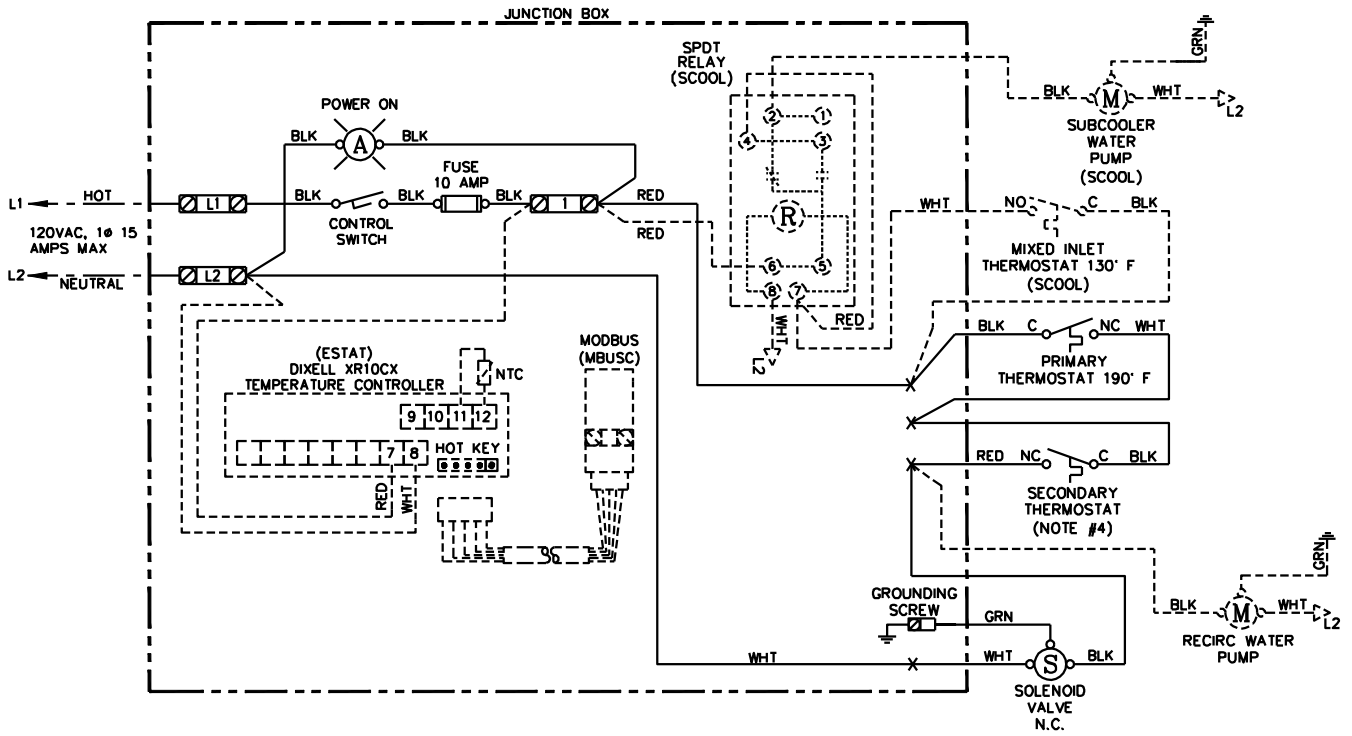

CSX and CSXT SERIES WATER HEATER

8.2 CSXT

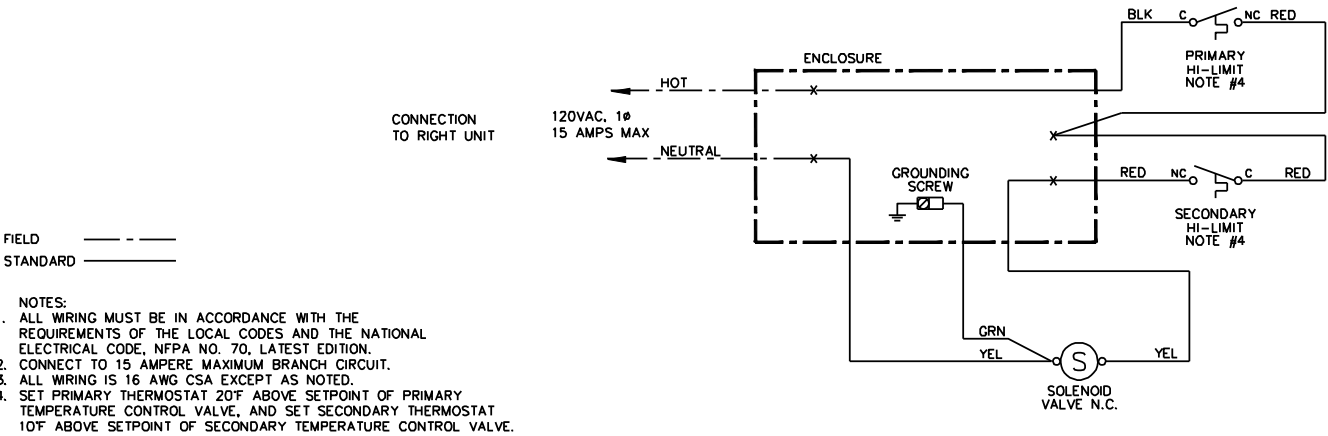
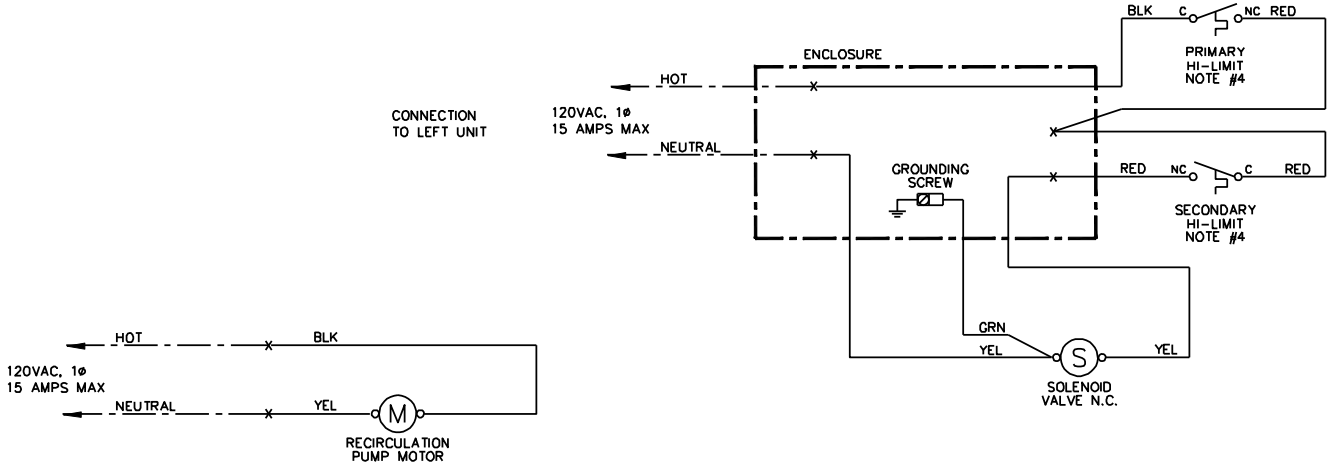

FIELD - - - - -
STANDARD - - - - -

- NOTES:
1. ALL WIRING MUST BE IN ACCORDANCE WITH THE REQUIREMENTS OF THE LOCAL CODES AND THE NATIONAL ELECTRICAL CODE, NFPA NO. 70, LATEST EDITION.
 2. CONNECT TO 15 AMPERE MAXIMUM BRANCH CIRCUIT.
 3. ALL WIRING IS 16 AWG CSA EXCEPT AS NOTED.
 4. SET PRIMARY THERMOSTAT 20°F ABOVE SETPOINT OF PRIMARY TEMPERATURE CONTROL VALVE, AND SET SECONDARY THERMOSTAT 10°F ABOVE SETPOINT OF SECONDARY TEMPERATURE CONTROL VALVE.

CSX and CSXT SERIES WATER HEATER

Since PVI cannot control the use of the appliance, water conditions, or maintenance, the warranty on the CSX / CSXT Water Heater does not cover poor performance, structural failure, or leaking due to an excessive accumulation of scale.

Warranty Forms Ship Separately with Each Product

MODEL NUMBER: _____

SERIAL NUMBER: _____

INSTALLATION DATE: _____