

EZ Plate Storage[®]

Packaged Domestic Hot Water Generator

AquaPLEX[®]
Engineered Duplex Alloy



Up to 6000 MBH | 250 to 1000 Gallon Tank | 25-year Warranty

PVI.com



Packaged Domestic Hot Water Generator

EZ Plate® storage water heaters provide reliable domestic hot water from boiler water utilizing a double-wall, brazed plate, heat exchanger. Plate heat exchangers are ideal for use with condensing boiler water systems because they allow the production of hot domestic water from lower temperature boiler water. Boiler water needs to only be 10°F hotter than the desired domestic water temperature. The heat exchanger and the tank are connected with factory-assembled piping. The heat exchanger is external to the tank providing a smaller footprint than traditional u-tube storage water heaters.

EZ Plate storage also offers dual heat exchanger models stacked to maintain a small footprint. These models can provide double the capacity or be run independent of each other, providing 100% redundancy. The heater allows for isolation of each heat exchanger to provide cleaning and maintenance without any system downtime.

Features and Benefits

- Up to 6000 MBH output
- 250 / 300 / 400 / 500 / 600 / 750 / 900 / 1000 storage tanks
- 100% redundant (dual) heat exchanger designs available
- Domestic water temperature to 180°F
- Skid-mounted with factory pre-assembled piping
- Electronic operating control is Modbus connectable to a building automation system
- No boiler water control valve is required with boiler water temperatures up to 180°F
- AquaPLEX® duplex stainless steel tank with 25-year corrosion warranty (15 years full, 10 years pro-rated)

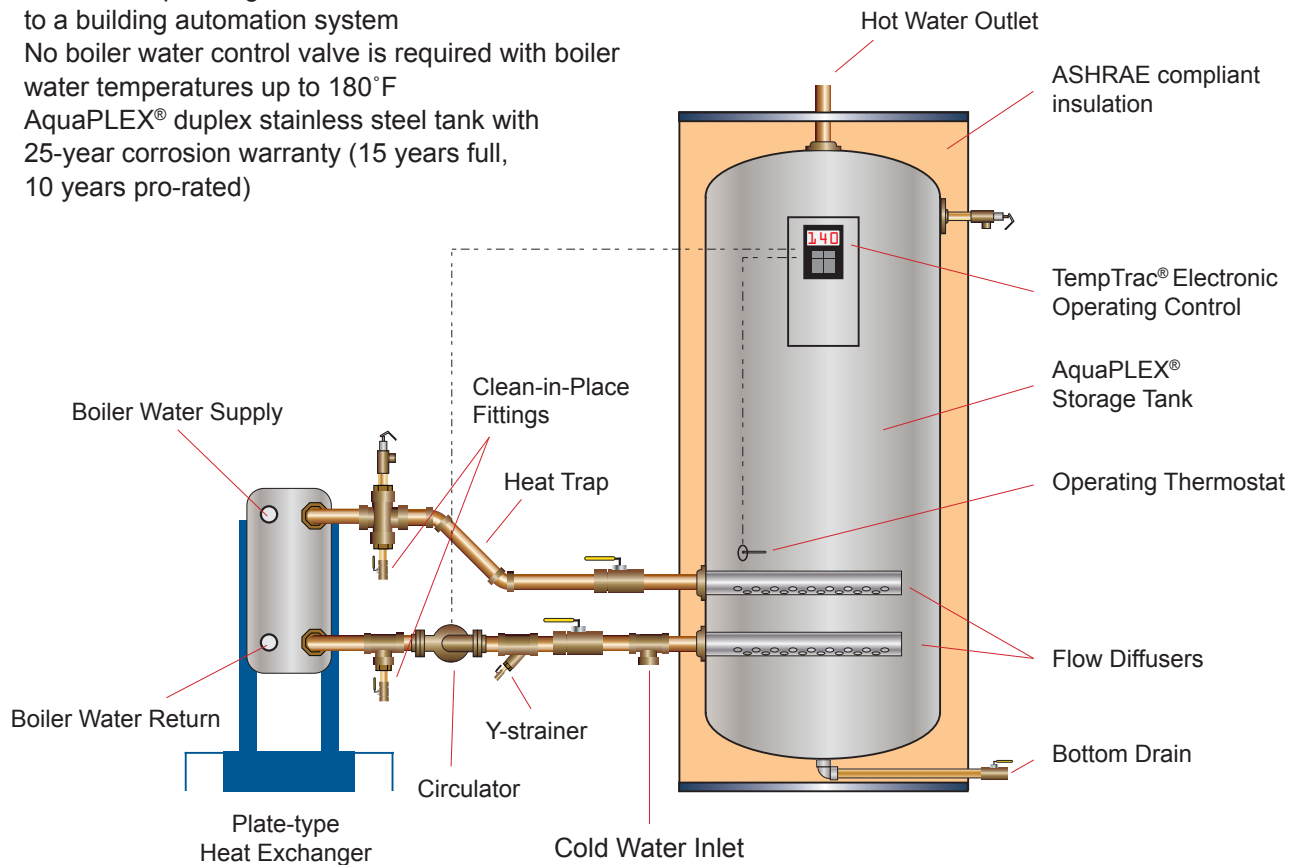

Illustrations are conceptual only and are not engineering drawings.

Plate Heat Exchanger Benefits

Due to their unique heat transfer characteristics, plate heat exchangers excel when applied in low- temperature boiler water loops. A plate exchanger, when supplied with 145°F boiler water, can produce 140°F domestic hot water while reducing boiler water return temperature to 100°F or lower. This is highly beneficial in condensing boiler systems where efficiency improves with reductions in both supply and return water temperature.

By comparison, u-tube heat exchangers are typically sized for a 20°F difference between the entering boiler water temperature and the desired domestic hot water outlet temperature. In addition, the boiler return water cannot be lower than the domestic hot water outlet temperature. For example, to produce 140°F domestic hot water, a u-tube exchanger would require 160°F entering boiler water and return boiler water would be no less than 141°F; temperatures above the ideal range for condensing boilers.

Benefits

- Compact footprint
- Ideal for high-pressure applications up to 362 psi
- Maximum heat transfer ideal for condensing boiler efficiency

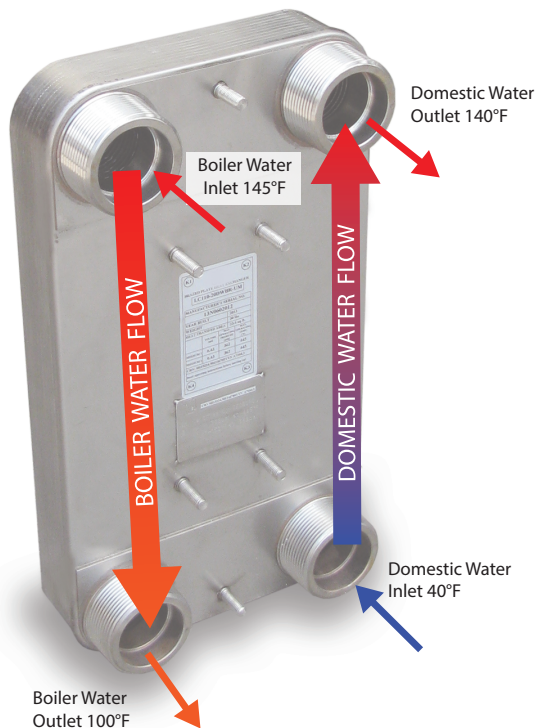

Inside the plate exchanger, counter-flows of boiler and domestic water maximize the temperature differentials and allow the temperatures of the opposing liquids to “cross” with boiler return water becoming colder than domestic outlet water.

Sequence of Operation

Demand for hot water causes a temperature drop in the storage tank as cold makeup water displaces the hot water in the tank. The tank thermostat senses this temperature drop and signals the operator to energize the circulator. Cold domestic water flows through the heat exchanger, captures heat from the boiler water and returns to the storage tank. Flow diffusers reduce the velocity of water leaving and returning to the storage tank from the heat exchanger. This eliminates turbulence in the storage tank and preserves the natural temperature stratification, allowing delivery of 80% of the storage tank's capacity at the desired set point temperature.

When tank temperature returns to the desired set point, the circulator is de-energized. If the installation includes an optional boiler water control valve, the electronic operator will energize and de-energize the valve as it energizes and de-energizes the pump.

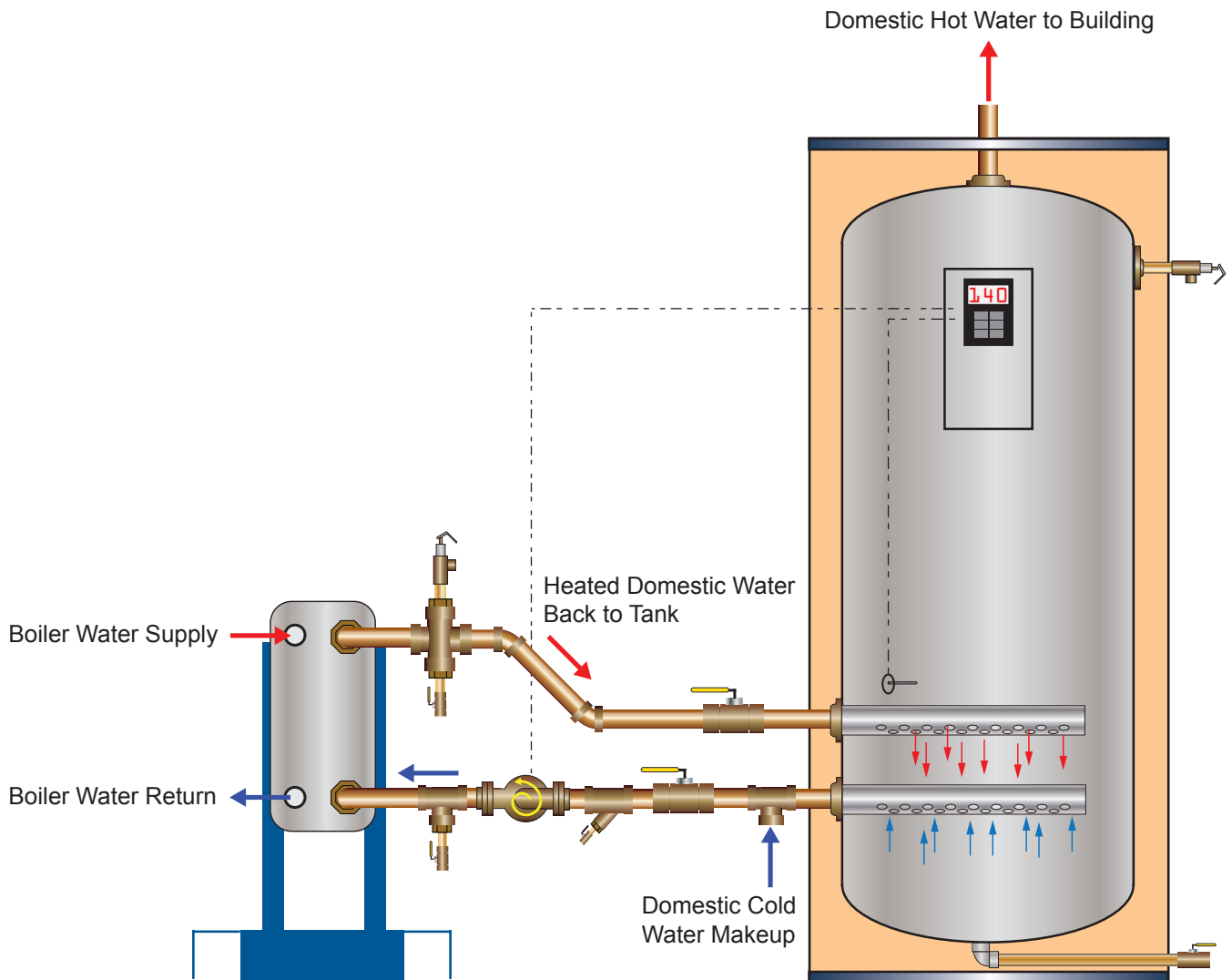

Boiler Water Control is Optional

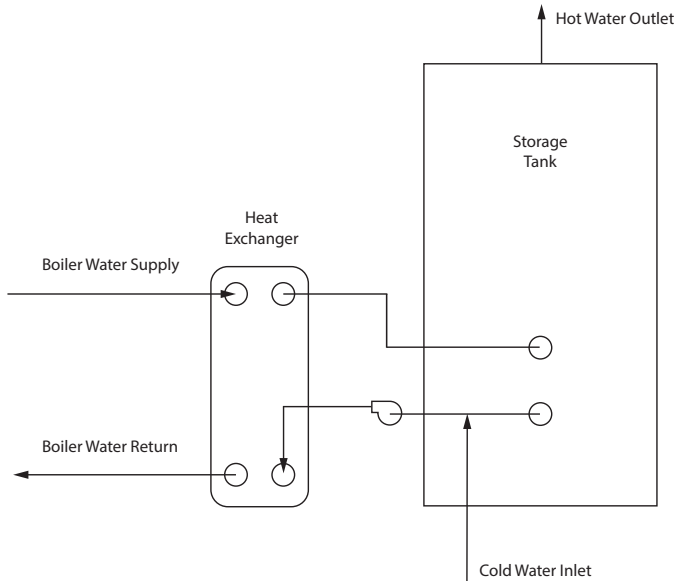

No Boiler Water Control Valve Needed

Constant boiler water flow through the heat exchanger is acceptable because heat transfer to the domestic water is controlled entirely by the circulator between the tank and heat exchanger. Constant flow at the water heater is also a logical choice for boiler loops equipped with VFD pump controls because domestic hot water is a year-round requirement in continual need of boiler water flow.

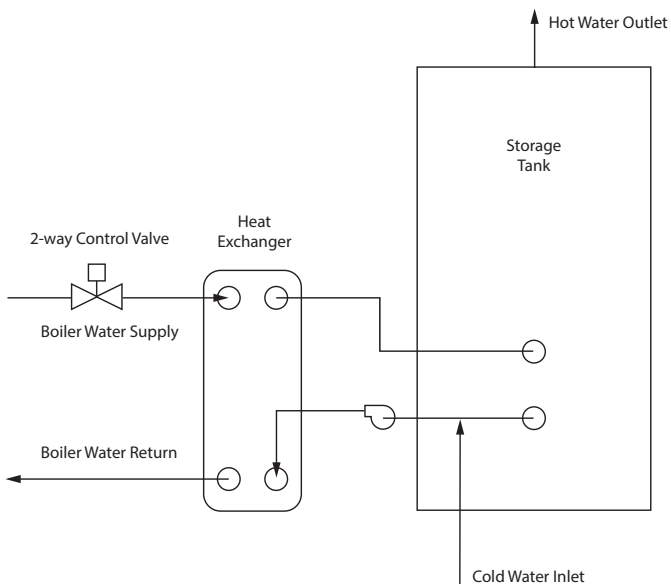

2-Way Boiler Water Control Valve

If the water heater is not utilized as the constant flow bypass in a VFD-equipped boiler loop and boiler flow is to be allowed only during a domestic water call for heat, the plate heat exchanger can be equipped with a motorized 2-way valve. In this configuration, the boiler water 2-way valve and the circulator are controlled by the TempTrac operator. Boiler water flow will then only occur during a call for domestic hot water.

Features and Codes

Heat Exchanger and Controls

- 316 stainless steel, double-wall, brazed-plate heat exchangers with ASME safety relief valve
- ASME-stamped Section VIII for 362 psi and 445°F
- 2-1/2" NPT connections
- Factory assembled exchanger-to-tank piping with clean-in-place fittings, bronze y-strainer, non-ferrous pump and fittings. (utilizing Viega® ProPress®)
- Programmable electronic operating control with digital temperature readouts (BAS connectable via Modbus RTU)
- High temperature limit
- 2-way boiler water control valve (optional)

Storage Tanks

- ASME stamped HLW for 150 psi
- ASME-rated temperature and pressure relief valve
- Bottom drain valve
- ASME stamped up to 250 psi operating pressure (optional)
- For larger vertical and horizontal storage tanks, consult PVI representative.

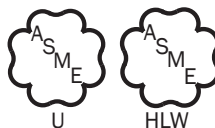

Model Prefixes and Recoveries

Single-Heat Exchanger Models

Model Prefix	GPH @ 40°F to 140°F with 150°F boiler water
600	353
900	530
1200	706
1800	1059
2400	1412
3000	1765
3600	2118
4500	2648
5400	3177

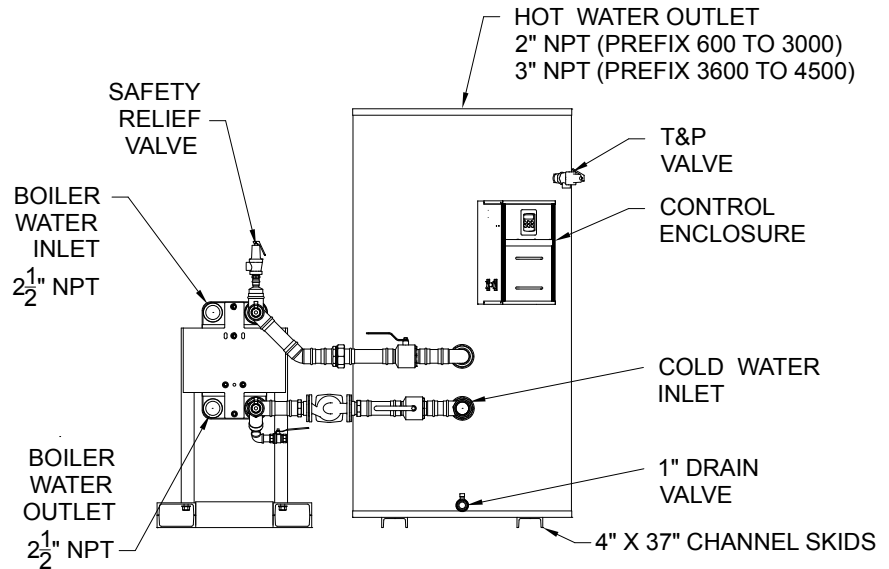

Dual-Heat Exchanger and Dual Pump Models

Model Prefix	GPH @ 40°F to 140°F with 150°F boiler water
600-2	706
900-2	1060
1200-2	1412
1800-2	2118
2400-2	2824
3000-2	3530
3600-2	4236
4500-2	5396
5400-2	6354

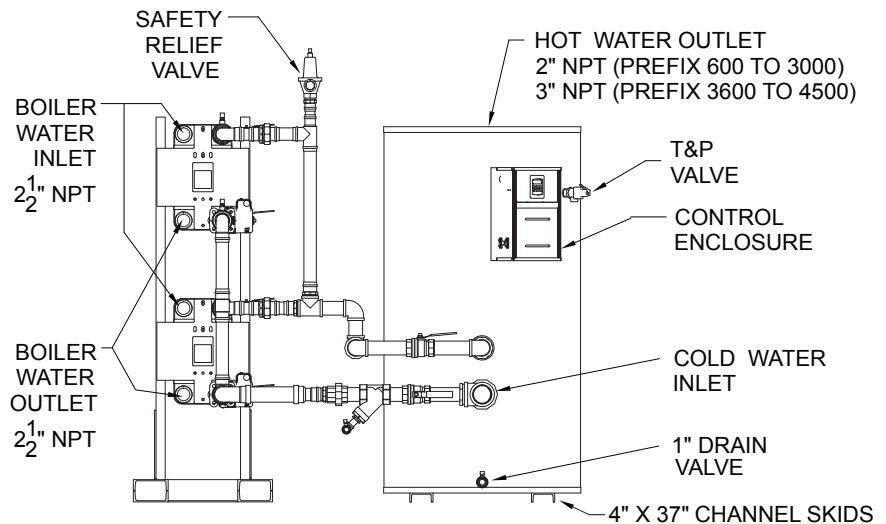

Electrical Requirements

115/120VAC 60Hz. 11 amps



Hot Water Solutions

PVI Industries | Fort Worth, TX
T: (817) 335-9531 | Toll Free: (800) 784-8326 | PVI.com