

LOW NO_x TURBOPOWER® • PACKAGED WATER HEATER
 AquaPLEX® STORAGE TANK (UNLINED DUPLEX ALLOY)

TANK SERIES 150 GALLONS VERTICAL

MODEL NUMBER	Recovery gph ①		INPUT Btu/h	Min. Inlet Flow Gas Pressure " W.C. ③	SCAQMD Energy Model No.				Blower Motor		Shipping Weight lbs
	40° - 120°F	40° - 140°F					A	B	HP	Amps	
250 L 150A-TPL	250	200	199,000	4.5	2TPL	199 MBtu/h	4	3/4	1/6	3	1035
375 L 150A-TPL	375	300	300,000	4.5	3TPL	299 MBtu/h	4	3/4	1/6	3	1045
500 L 150A-TPL	500	400	399,000	4.5	4TPL	399 MBtu/h	5	3/4	1/6	3	1055

- ① Recoveries based on 83% thermal efficiency. ASHRAE 90.1 compliant for efficiency and standby loss.
- ② Dimension is for the burner housing only – gas train may exceed this dimension.
- ③ Standard gas train.
- * The information presented is for natural gas 0.6 S.G.
 Minimum inlet pressure for LP = 8.0 W.C.
 Dimensions are in inches unless otherwise specified.
 For standard and optional equipment, see form #PV8089.

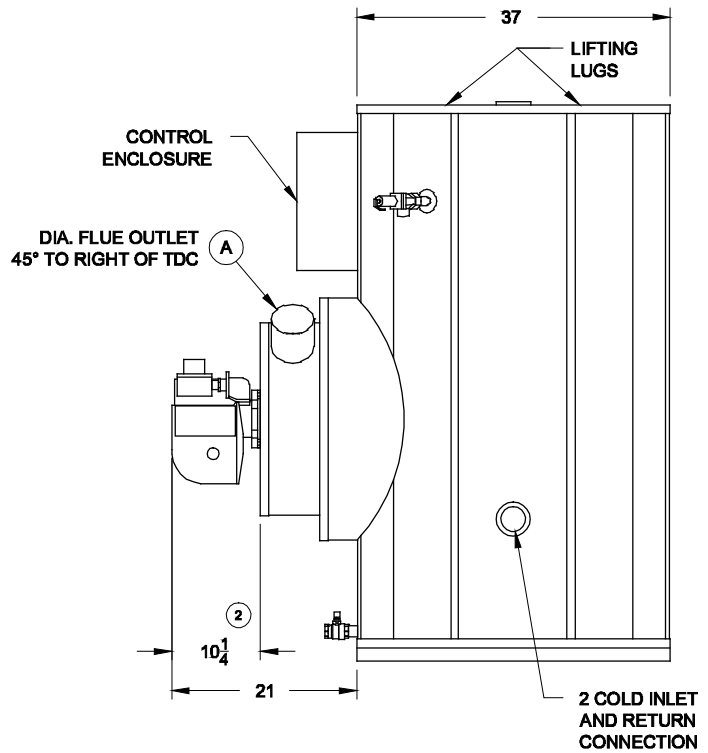
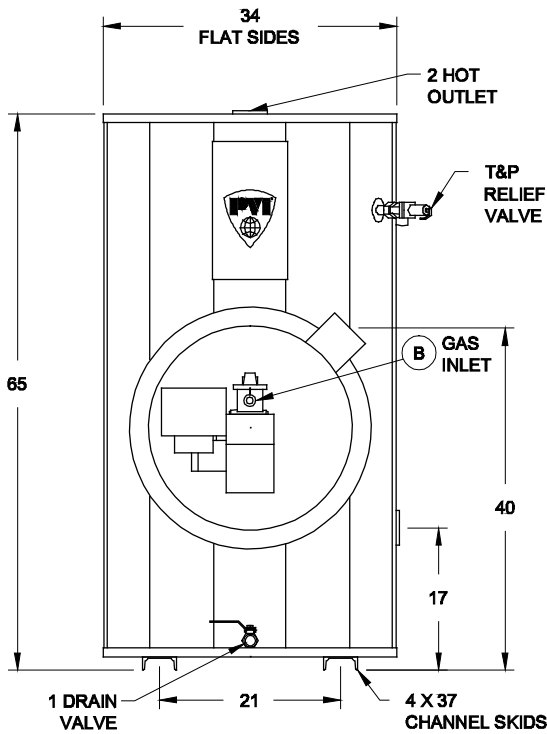

STANDARD GAS PRESSURE REQUIREMENTS:
 SEE TABLE FOR MINIMUM PRESSURE BY MODEL NUMBER.
 MAXIMUM STATIC INLET GAS PRESSURE IS 10.5" W.C.
 FOR GAS PRESSURES OUTSIDE OF THIS RANGE,
 CONTACT YOUR PVI REPRESENTATIVE.

VENTING REQUIREMENTS:
 -.02" TO -.06" W.C. (NEGATIVE PRESSURE).
 TYPE B VENTING.
**ENTIRE VENT SYSTEM SHOULD NEVER BE SIZED BASED UPON
 THE VENT CONNECTION DIAMETER EXCLUSIVELY. CHECK
 NATIONAL FUEL GAS CODE UNDER "FAN ASSISTED."**

STANDARD ELECTRICAL REQUIREMENTS:
CONTROL VOLTAGE: 120V, 1Ø, 60 HZ., 2 AMPS.
MOTOR VOLTAGE: 120V, 1Ø, 60 HZ.

PVI RESERVES THE RIGHT TO CHANGE THE DESIGN AND SPECIFICATION WITHOUT NOTICE.



PVI INDUSTRIES, LLC
 FORT WORTH, TEXAS 76111
 (800) 784-8326 • www.pvi.com