

# TURBOPOWER® GAS/OIL • PACKAGED WATER HEATER

## AquaPLEX® STORAGE TANK (UNLINED DUPLEX ALLOY)

### TANK SERIES 1500 GALLONS

Model Number	Recovery gph ①		Input Btu/h	Min. Inlet Flow Gas Pressure "W.C. ③	#2 Oil gph	Max. oil gph (gear capacity) ④	Dimensions (inches)				Blower Motor		Shipping Weight lbs
	40°- 120°F	40°- 140°F					A	B	C	J ②	HP	Volt/Ph/Amps	
750 L 1500A-TPGO	750	600	600,000	4.5	4.3	20	46	6	1	31	1/2	115/1Ø/110	3795
1000 L 1500A-TPGO	1000	800	800,000	6.0	5.7	20	46	8	1	31	1/2	115/1Ø/110	3835
1250 L 1500A-TPGO	1250	1000	1,000,000	7.5	7.2	20	46	8	1	31	3/4	115/1Ø/110	3925
1500 L 1500A-TPGO	1500	1200	1,200,000	7.5	8.6	20	46	8	1-1/4	31	1	115/1Ø/110	4005

① Recoveries based on 83% thermal efficiency. ASHRAE 90.1 compliant for efficiency and standby loss.

② "J" dimension is for the burner housing only. Gas train may exceed this dimension.

③ Standard gas train.

④ Standard gear capacities may change depending on burner supplier.

Designer must use gear capacities from the above chart to size the oil distribution piping system; including transfer pumps (if used).

\* The information presented is for Natural gas 0.6 S.G.—For operation with Propane (LP gas), consult factory.

Dimensions are in inches unless otherwise specified.

For standard and optional equipment, see form PV 8183.

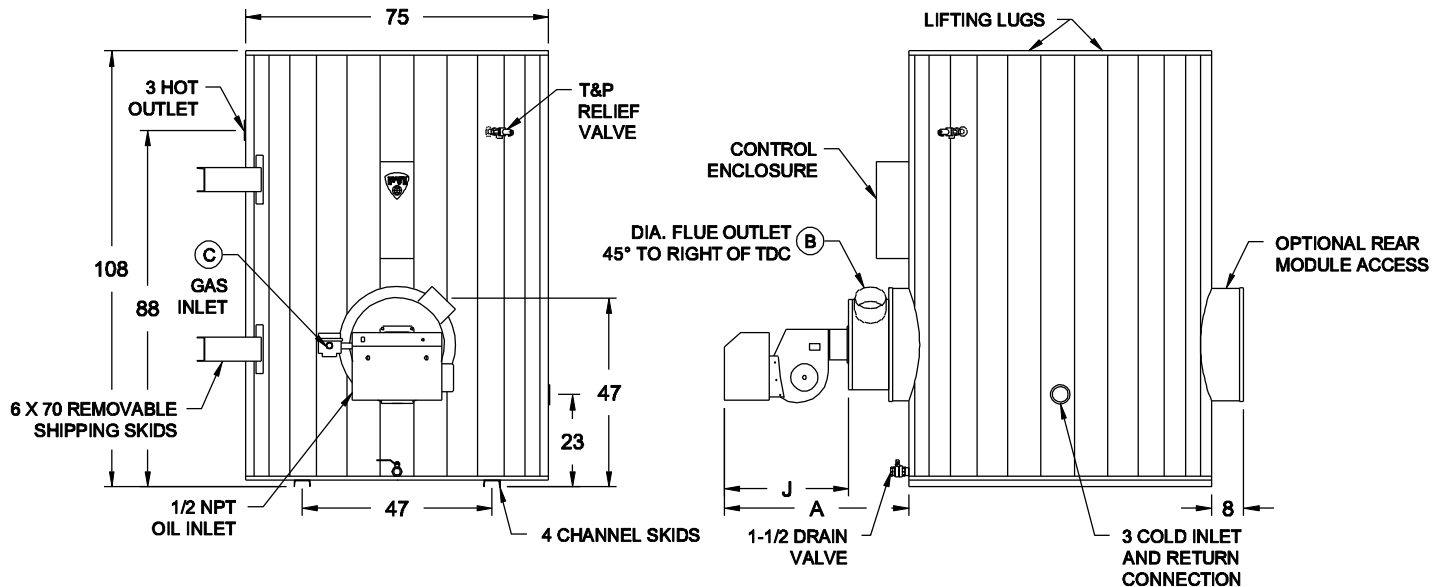

**\* GAS PRESSURE REQUIREMENTS**

SEE TABLE FOR MINIMUM PRESSURE BY MODEL NUMBER.  
 MAXIMUM STATIC INLET PRESSURE: 14" W.C.  
 FOR PRESSURES OTHER THAN LISTED, CONSULT FACTORY.  
 Pressure shown is for standard UL gas train. Additional controls may increase pressure requirements.

**VENTING REQUIREMENTS**

-0.02" TO -.06" W.C. (NEGATIVE PRESSURE)  
 ENTIRE VENT SYSTEM SHOULD NEVER BE SIZED BASED UPON THE VENT CONNECTION DIAMETER EXCLUSIVELY.  
 FOR PROPER SIZING, CONSULT THE NATIONAL FUEL GAS CODE UNDER "FAN-ASSISTED."

**STANDARD ELECTRICAL REQUIREMENTS**

CONTROL VOLTAGE: 120V, 1Ø, 60 HZ., 2 AMPS.  
 MOTOR VOLTAGE:  
 208V, 230V, AND 460V MOTORS ARE AVAILABLE BUT WILL REQUIRE A SEPARATE 120V/2 amps CONTROL CIRCUIT OR AN OPTIONAL CONTROL CIRCUIT TRANSFORMER.

PVI RESERVES THE RIGHT TO CHANGE THE DESIGN AND SPECIFICATION WITHOUT NOTICE.

