

TURBOPOWER® GAS/OIL • PACKAGED WATER HEATER

AquaPLEX® STORAGE TANK (UNLINED DUPLEX ALLOY)

TANK SERIES 215 GALLONS

Model Number	Recovery gph ①		Input Btu/h	Min. Inlet Flow Gas Pressure "W.C. ③	#2 Oil gph	Max. oil gph (gear capacity) ④	Dimensions (inches)		Blower Motor		Shipping Weight lbs
	40°- 120°F	40°- 140°F					A	B	HP	Volt/Ph/ Amps	
750 L 215A-TPGO	750	600	600,000	4.5	4.3	20	6	1	1/2	115/1Ø/110	1750
1000 L 215A-TPGO	1000	800	800,000	6.0	5.7	20	8	1	1/2	115/1Ø/110	1790

- ① Recoveries based on 83% thermal efficiency. ASHRAE 90.1 compliant for efficiency and standby loss.
- ② Dimension is for the burner housing only. Gas train may exceed this dimension.
- ③ Standard gas train.
- ④ Standard gear capacities may change depending on burner supplier.
Designer must use gear capacities from the above chart to size the oil distribution piping system; including transfer pumps (if used).
- * The information presented is for Natural gas 0.6 S.G.—For operation with Propane (LP gas), consult factory.
Dimensions are in inches unless otherwise specified.
For standard and optional equipment, see form PV 8183.

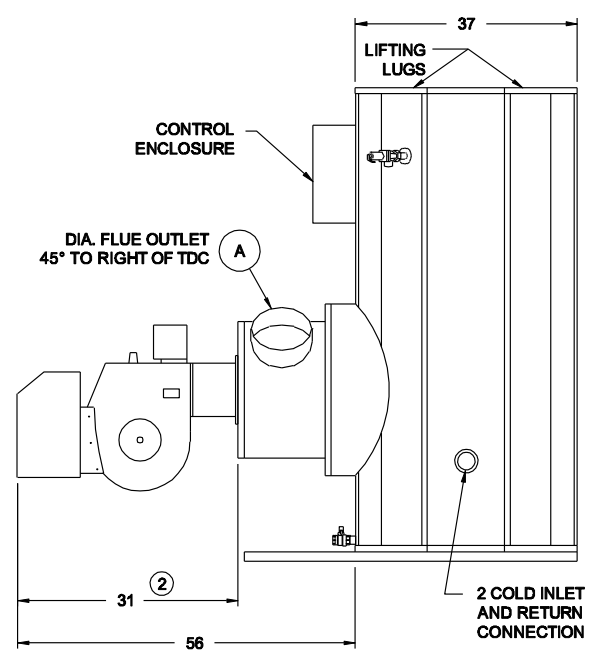
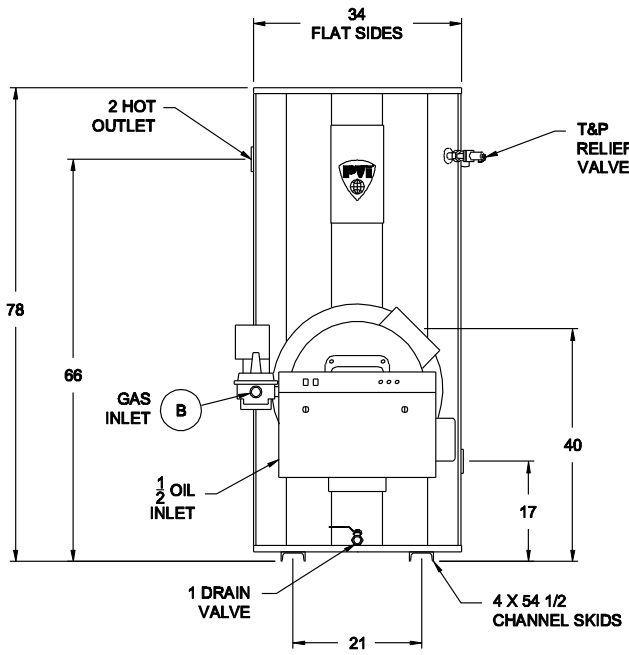

*** GAS PRESSURE REQUIREMENTS**

SEE TABLE FOR MINIMUM PRESSURE BY MODEL NUMBER.
 MAXIMUM STATIC INLET PRESSURE: 14" W.C.
 FOR PRESSURES OTHER THAN LISTED, CONSULT FACTORY.
 Pressure shown is for standard UL gas train. Additional controls may increase pressure requirements.

VENTING REQUIREMENTS

-.02" TO -.06" W.C. (NEGATIVE PRESSURE)

*ENTIRE VENT SYSTEM SHOULD NEVER BE SIZED BASED UPON THE VENT CONNECTION DIAMETER EXCLUSIVELY.
 FOR PROPER SIZING, CONSULT THE NATIONAL FUEL GAS CODE UNDER "FAN-ASSISTED."*

STANDARD ELECTRICAL REQUIREMENTS

CONTROL VOLTAGE: 120V, 1Ø, 60 HZ., 2 AMPS.
 MOTOR VOLTAGE:
 208V, 230V, AND 460V MOTORS ARE AVAILABLE BUT WILL REQUIRE A SEPARATE 120V/2 amps CONTROL CIRCUIT OR AN OPTIONAL CONTROL CIRCUIT TRANSFORMER.

PVI RESERVES THE RIGHT TO CHANGE THE DESIGN AND SPECIFICATION WITHOUT NOTICE.