



TURBOPOWER® GAS • PACKAGED WATER HEATER

AquaPLEX® STORAGE TANK (UNLINED DUPLEX ALLOY)

TANK SERIES 600 GALLONS

Model Number ③	Recovery gph ①		Input Btu/h	* Min. Inlet Flow Gas Pressure "W.C.	Dimensions (inches)					Blower Motor		Shipping Weight lbs
	40°- 120°F	40°- 140°F			A	B	C	J ∅	K	HP	Volt/Ph/ Amps	
250 L 600A-TPL	250	200	199,000	4.5	21	4	3/4	10-1/4	43	1/6	115/1∅/3	2040
375 L 600A-TPL	375	300	300,000	4.5	21	4	3/4	10-1/4	43	1/6	115/1∅/3	2050
500 L 600A-TPL	500	400	399,000	4.5	21	5	3/4	10-1/4	43	1/6	115/1∅/3	2060
750 L 600A-TP	750	600	600,000	6.0	28-1/2	6	1	16	43	1/3	115/1∅/8	2140
1000 L 600A-TP	1000	800	800,000	6.0	28-1/2	8	1-1/4	16	43	1/3	115/1∅/8	2180
1250 L 600A-TP	1250	1000	1,000,000	6.0	36-1/2	8	2	16	43	1/2	115/1∅/10	2435
1500 L 600A-TP	1500	1200	1,200,000	6.5	36-1/2	8	2	16	43	1/2	115/1∅/10	2445
2000 L 600A-TP	2000	1600	1,600,000	9.0	51-1/2	10	2	27	43	1-1/2	115/1∅/20	2880
2500 L 600A-TP	2500	2000	2,010,000	10.5	51-1/2	10	2-1/2	27	43	1-1/2	115/1∅/20	2900

- ① Recoveries based on 83% thermal efficiency. ASHRAE 90.1 compliant for efficiency and standby loss.
 - ② "J" dimension is for the burner housing only. Gas train may exceed this dimension.
 - ③ Models with "TPL" suffix are less than 55 ppm NOx. SCAQMD models 2TPL (200MBH), 3TPL (300MBH) and 4TPL (400MBH).
 - * The information presented is for Natural gas 0.6 S.G.— For operation with propane (LP gas), consult factory.
 - ** Consult the factory.
- Dimensions are in inches unless otherwise specified.
For standard and optional equipment, see form PV 8050.

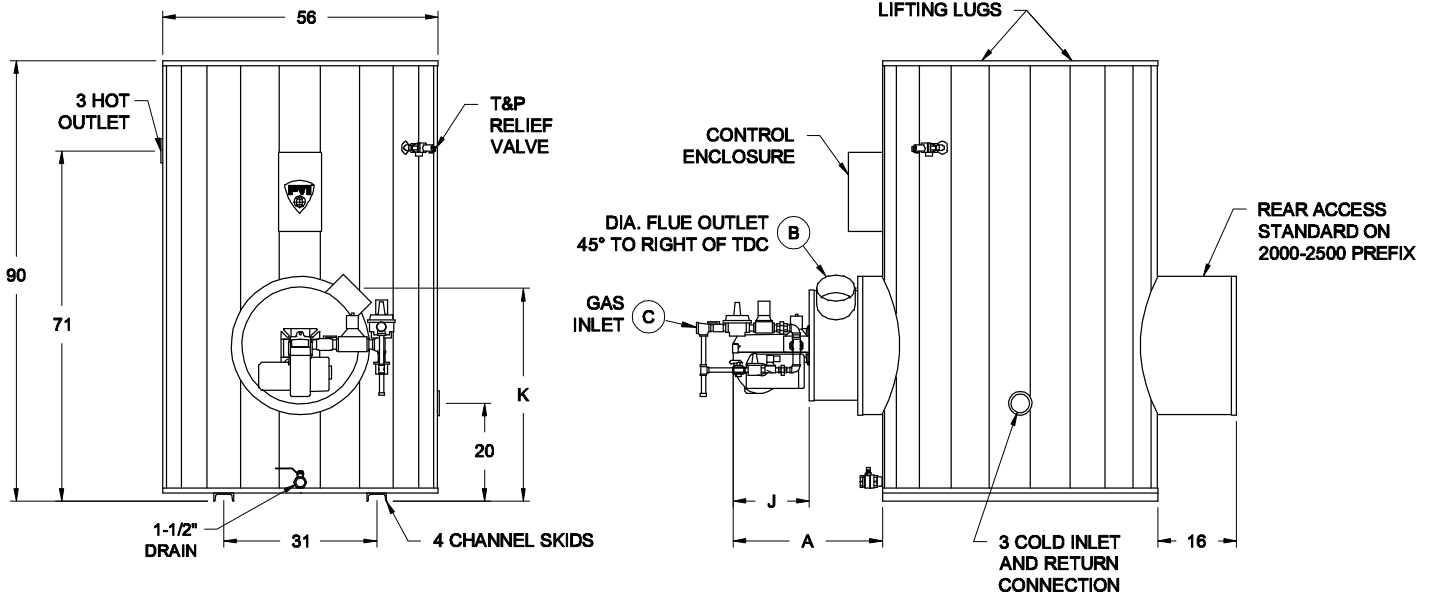

*** GAS PRESSURE REQUIREMENTS**

SEE TABLE ABOVE FOR **MINIMUM** PRESSURE BY MODEL NUMBER.
MAXIMUM STATIC INLET PRESSURE:
 10.5" W.C. for 199,000 - 399,000 AND 14" W.C. for > 399,000.

VENTING REQUIREMENTS

-.02" TO -.06" W.C. (NEGATIVE PRESSURE)
 CATEGORY I, TYPE B VENTING
*ENTIRE VENT SYSTEM SHOULD NEVER BE SIZED BASED UPON THE VENT CONNECTION DIAMETER EXCLUSIVELY.
 FOR PROPER SIZING, CONSULT THE NATIONAL FUEL GAS CODE UNDER "FAN-ASSISTED."*

STANDARD ELECTRICAL REQUIREMENTS

CONTROL VOLTAGE: 120V, 1∅, 60 HZ., 2 AMPS.
 MOTOR VOLTAGE:
 208V, 230V, AND 460V MOTORS ARE AVAILABLE BUT WILL REQUIRE A SEPARATE 120V/2 amps CONTROL CIRCUIT OR AN OPTIONAL CONTROL CIRCUIT TRANSFORMER.

PVI RESERVES THE RIGHT TO CHANGE THE DESIGN AND SPECIFICATION WITHOUT NOTICE.