

SERIES 35-67



24 VAC Microprocessor Based Proven HSI Control with Combustion Blower Relay

35.67.03

FEATURES

- Combustion blower output
- Proven pressure switch input
- 24/120/240 VAC hot surface ignitor models available
- ASME CSD-1 compatible models available (consult factory)
- Pre-purge and lockout indicator outputs
- Non-volatile lockout option
- Diagnostic LED and remote LED connection
- Multiple trials for ignition
- Thermostat, pushbutton or remote reset
- Full-time flame sensing
- Remote flame sensor option
- Flame current test pins

APPLICATIONS

Commercial and industrial appliances with combustion chambers in excess of 400K BTU. Applications requiring CSD-1 certification.

DESCRIPTION

The Series 35-67 is a hot surface ignition system in which the ignition source is proven to be capable of ignition prior to the gas valve being opened and is suitable for appliances over 400K BTU. Models compatible to the requirements of ASME standard CSD-1 are available.

The microprocessor circuit design provides precise, repeatable timing sequences for ignition times and purge times (pre-, inter-, and post-) as well as multiple tries for ignition. The control also continuously monitors the pressure switch, thermostat and main burner flame to ensure safe system operation. On-board diagnostics with LED output provide assistance with troubleshooting to ensure safe and efficient burner operation.

Agency Certifications

 Design certified by CSA International to CAN C22.2 #199-M89 and ANSI Z21.20 for Automatic Ignition Systems, including UL1998 Software Review.

 Special models approved to EN298:2003 available upon request.



SPECIFICATIONS

INPUT VOLTAGES	
Control	18 to 30 VAC, 400mA max (not including gas valve)
Line (L1 & L2 to Ignitor)	120 VAC standard, 24 VAC and 240 VAC models available
Thermostat	18 to 30 VAC 30mA max (not incl. Gas Valve)
Pressure Switch (Airflow)	18 to 30 VAC 25mA max
OUTPUT RATINGS	
Combustion Blower	15A max (0.6 pf) or 1/2 HP @ 120 or 240 VAC
Hot Surface Ignitor	5.0A max @ 24, 120 or 240 VAC
Gas Valve Rating	5.0A max (0.6 pf) @ 24 VAC
Lockout & Pre-Purge Indicators	1.0A max @ 24 VAC
OPERATING TEMPERATURE	-40°F to +165°F (-40°C to +73°C)
FLAME SENSITIVITY	1.0 micro Amp minimum
FLAME FAILURE RESPONSE TIME	0.8 seconds max
TYPES OF GAS	Natural, LP, or manufactured
ENCLOSURE	Gray (Noryl N-190)
MOISTURE RESISTANCE	Conformal coated to operate non-condensing to 95% R.H. Care must be taken to protect module from direct exposure to water
SIZE WITH ENCLOSURE	See Figures 6 & 7
WEIGHT	8oz including options and cover

SEQUENCE OF OPERATION

1. POWER-UP.

Power is applied to the full time 24 volt input. The micro-processor will start a self-check routine of about five seconds. After this delay, the LED will come on and the control is ready to start a new call for heat.

Non-volatile Lockout Models Only

Models of the 35-67 with non-volatile lockout will check memory to see if a lockout condition exists. If active, the lockout indicator will be on and the LED will repeatedly flash 3 times. To clear the non-volatile lockout the reset button must be pushed or 24 VAC applied to the reset input pin. The lockout indicator will turn off and the LED will be on steady indicating the control is ready for a new call for heat.

2. CALL FOR HEAT.

The thermostat is turned on. The control will verify the pressure switch contacts are open and combustion fan relay will turn on.

Proof of Pressure Switch. The control will look for a signal from the pressure switch, indicating that the fan is operating.

Pre-Purge Delay. When the pressure switch signal is seen, the pre-purge delay will start. The pre-purge indicator output will turn on.

Pressure Switch Option. Special models are available that respond to a ground signal present on pin 10 during the start of the heating sequence. This allows ignoring the open pressure switch contact test, or disabling airflow monitoring and blower operation when the ground is detected. This feature is useful in multiple-control installations where only the first module is responsible for controlling a common blower.

3. HEAT-UP.

After the pre-purge delay, power will be applied to the hot surface ignition element. The pre-purge indicator will turn off.

Current Proving. The 35-67 will monitor the current through the ignition element. When the current reaches a pre-determined level, the LED will flash once.

Dwell Time. From the point when the current has been proven, there will be a delay called dwell time. Dwell time assures that the ignition element has sufficient time to reach ignition temperature.

4. IGNITION. When dwell time is completed, the gas valve will open. The ignition element will turn off 2 seconds before the end of the ignition period.

No Flame.

Single Trial for Ignition. The control will go to post-purge, and then lockout.

Three Trials for Ignition. The control will make two additional purge/heatup/ignition cycles. If a flame is not proven, the control will go to post-purge, and then lockout.

Flame is Proven.

The gas valve will remain on beyond the normal ignition period. This continues as long as signals are present for the flame, thermostat and pressure switch.

5. LOSS OF FLAME SIGNAL. The gas valve will turn off. Depending on the model chosen:

Single Trial for Ignition Models. A new trial for ignition cycle will start.

Three Trial for Ignition Models. Three new ignition cycles will start.

Post-Purge. After all ignition cycles are complete, the control will enter post-purge. The combustion fan will remain on.

Lockout. After post-purge is complete, the combustion fan will turn off. The Lockout Indicator output will turn on. The LED will repeatedly flash three times.

SILICON CARBIDE IGNITOR

Proper location of the silicon carbide ignitor is important to achieve optimum system performance for both ignition and flame sensing. See Figure 1.

NOTE: The temperature of the ceramic holder should not exceed the manufacturer's specifications.

Figure 1

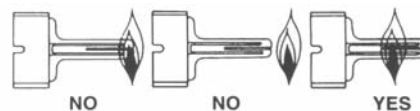

TYPICAL HOT SURFACE IGNITOR

Figure 2

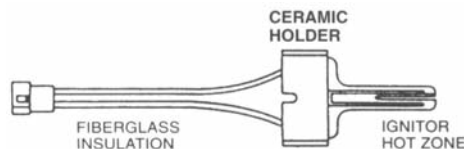

FLAME CURRENT MEASUREMENT

Flame current is the current that passes through the flame from sensor to ground. To measure flame current, connect a True RMS or analog DC micro-ammeter to the FC+ and FC- terminals. The reading should be 1.0 micro-amps DC or higher. If meter reads negative or below "0" on scale, meter leads are reversed. Re-connect meter leads with proper polarity.

Alternately, a Digital Voltmeter may be used to measure the DC voltage between the FC+ and FC- terminals. Each micro-amp of flame current will produce 1.0VDC, so a reading of 2.6VDC would equate to 2.6 micro-amps.

MOUNTING AND WIRING

The 35-67 is not position sensitive and can be mounted vertically or horizontally. The control may be mounted on any surface and fastened with #6 screws. Secure the control in an area that will experience a minimum of vibration and remain below the maximum ambient temperature of 73°C (165°F). All connections should be made with UL approved, 105°C (221°F) rated 18 gauge stranded wire with .054" minimum insulation. Refer to Figure 4A and Figure 5A on Page 5 when connecting the 35-67 to other components in the system.

continued above >

TERMINAL DESIGNATIONS - P1 CONNECTOR

Table 1

11-PIN MATING CONNECTOR AMP P/N 1-770849-1 PINS AMP P/N 350980-1		
PIN LOCATION	WIRE COLOR	DESCRIPTION
1	ORANGE	Lockout Indicator
2	RED	Thermostat
3	VIOLET	Lockout Indicator (Ground Side)
4	GRAY	Airflow (PSW)
5	BROWN	Gas Valve
6	BLUE	24 VAC (Full Time)
7	YELLOW	Reset Button
8	GREEN	Ground
9	WHITE	Pre-Purge Indicator
10	WH/BLACK	Pressure Switch Option
11	BLACK	Remote Sense

TERMINAL DESIGNATIONS - P2 & P3 CONNECTOR

Table 2

TERMINAL	DESCRIPTION	MATING CONNECTOR	QUICK CONNECTS
S1	Ignitor	Tyco 2-520183-2 PINS 350919-3	¼ inch optional
L1	24, 120 or 240VAC Input (Hot)		¼ inch optional
L2	Neutral		¼ inch optional
S2	Ignitor		¼ inch optional
F1	Inducer Power Supply		¼ inch
F2	Inducer Blower		¼ inch
P3/P7	Remote LED Connector	MOLEX 22-01-2021 PINS 08-500114	
FC+ & FC-	Flame Current Test Pins	Tyco 61260-1	



CAUTION:

Label all wires prior to disconnection when servicing the control. Wiring errors can cause improper and dangerous operation. A functional checkout of a replacement is recommended.



WARNING:

Operation outside specifications could result in failure of the Fenwal product and other equipment with injury or death to people and damage to property. Service to this product should only be preformed by a qualified technician

ON BOARD DIAGNOSTICS

LED INDICATION	FAULT MODE
ON	Normal Operation
OFF	Internal Control Failure - Check Power
1 Flash	Airflow Fault
2 Flashes	Erroneous Flame Signal
3 Flashes	Ignition Lockout
4 Flashes	Hot Surface Ignitor Fault
5 Flashes	Low Voltage (24 VAC)
6 Flashes	Valve Relay Problem

SOFT LOCKOUT RECOVERY

The control will attempt automatic recovery from Fault Codes 1,4,5, and 6 by a soft lockout mechanism. The control will wait 5 minutes and if the thermostat is still calling for heat it will attempt a restart sequence. If the error persists it will be detected and the control will continue in this soft lockout and retry sequence every 5 minutes until the problem is corrected.

TROUBLESHOOTING GUIDE

SYMPTOM	RECOMMENDED ACTIONS
Control will not start up	A. Miswired B. 24 VAC Transformer bad C. Fuse/Circuit breaker bad D. Bad control, check LED for steady or flashing codes
Thermostat on and no ignition	A. Miswired B. Bad thermostat, no voltage at thermostat terminal C. Failed ignitor
Valve on - no ignitor	A. Defective ignitor B. Miswired C. Bad control, check voltage at ignitor
Ignitor on - no valve	A. Valve coil open B. Open valve wire C. Bad control, check voltage at gas valve terminal
Flame okay during TFI but no flame sense after TFI	A. Bad ignitor B. Bad wire C. Poor ground at burner D. Poor flame, check flame current
LED off	A. Verify 24 VAC present B. Recycle Power C. If problem persists, replace control

CONTROL WIRE HARNESS

Select the proper harness based on the 35-67 control's termination connection. Once the terminal configuration is determined, complete the part number by replacing the last two digits ("XX") with the length in inches ("I" dimension). Standard wire lengths are 12, 18, 24, 30, 36 and 48 inches. Example 05-129845-018 = 18 inches. For other lengths, please contact Fenwal

Part Number: 05-129845-0XX

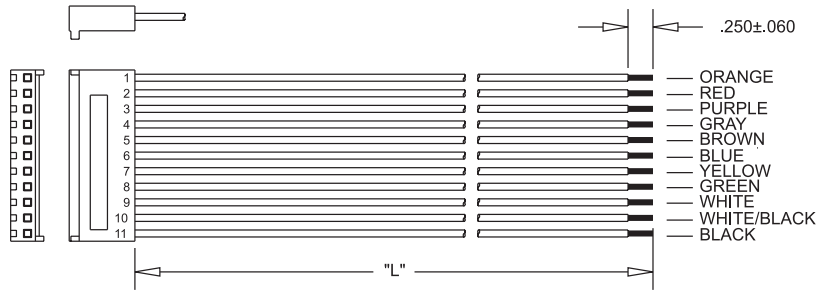

Part Number: 05-128981-XXX

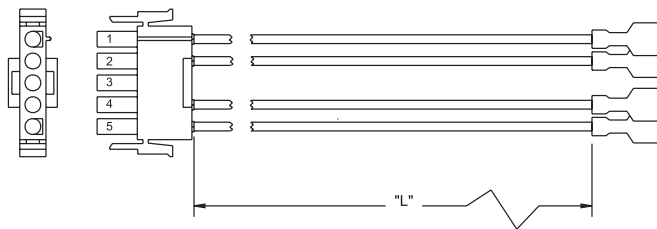

REMOTE FLAME SENSE ROD

Part Number: 22-100001-080

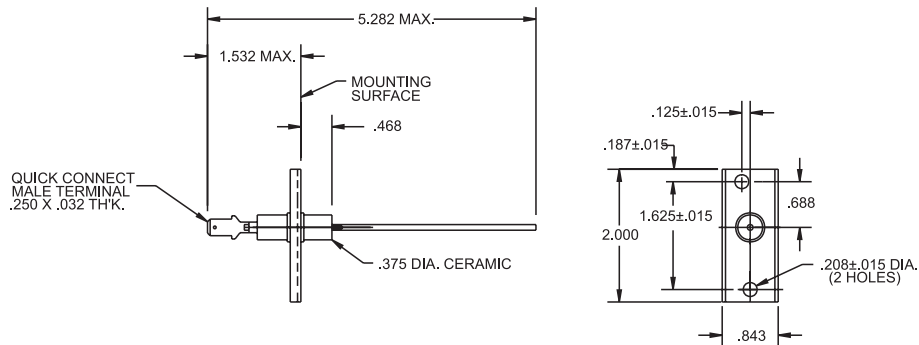

Part Number: 22-100001-110

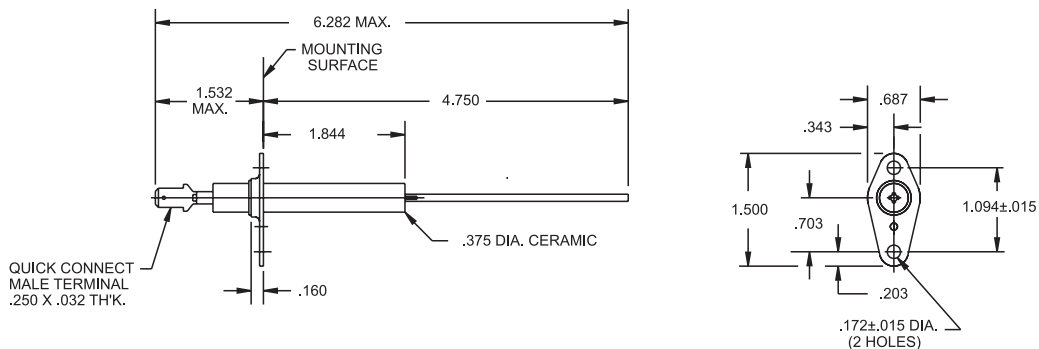

STANDARD DESIGN - AUTOMATIC RESET

WIRING

Figure 4A

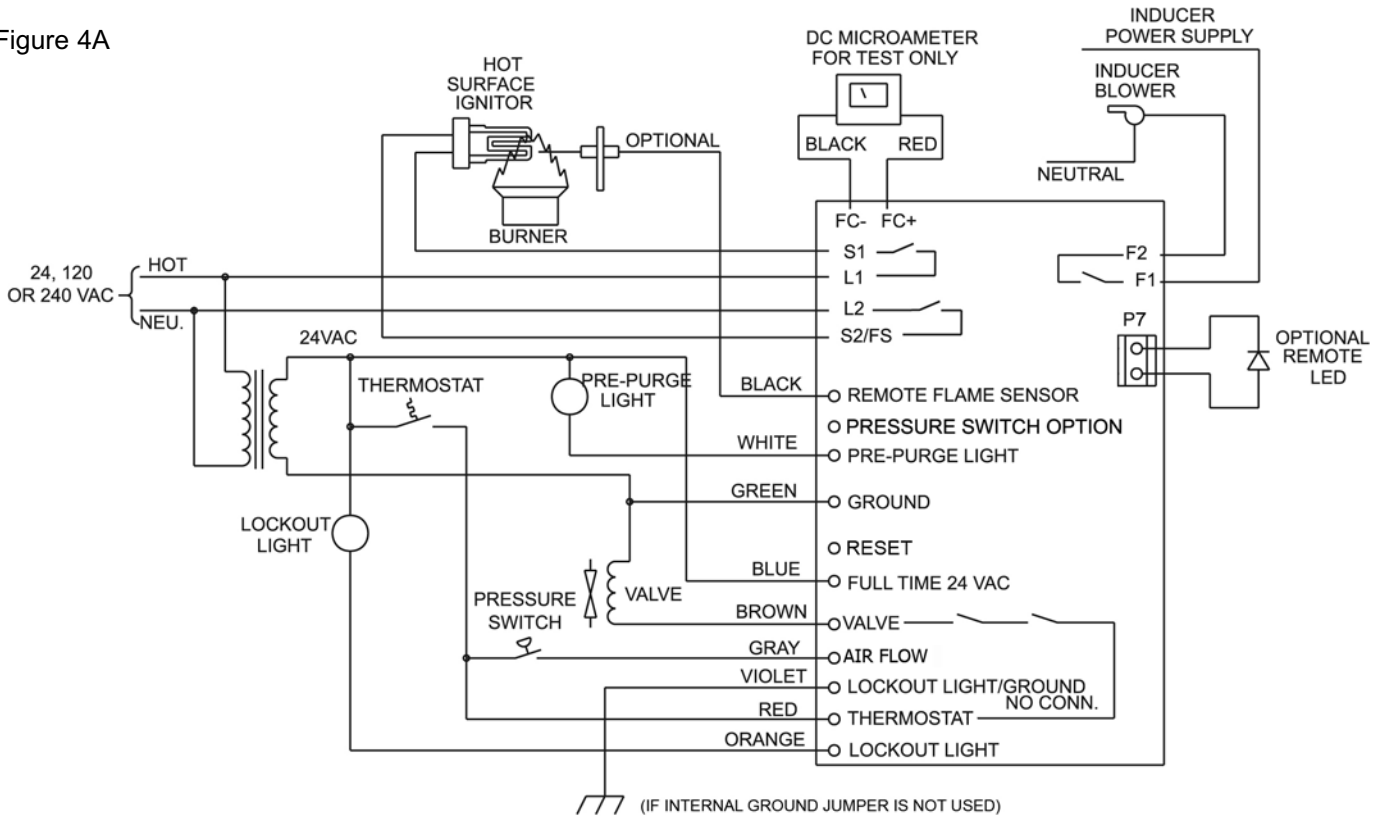

PIN LAYOUT

Figure 5A

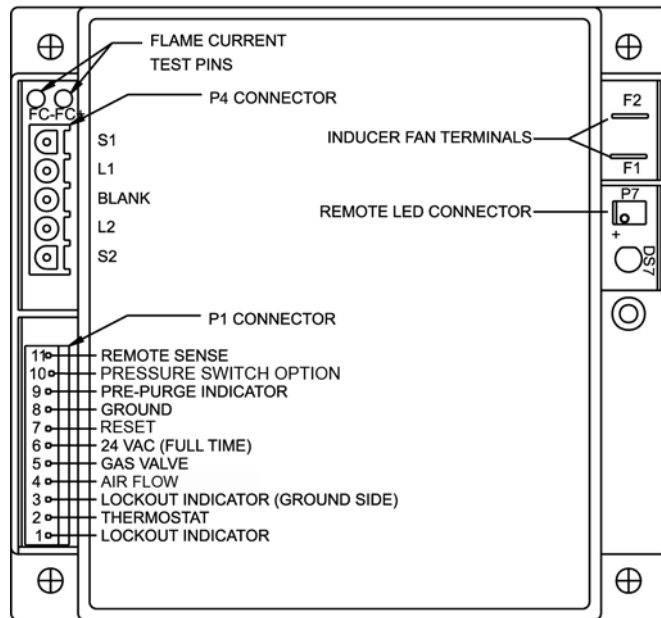

OPTIONAL DESIGN - MANUAL RESET

WIRING

Figure 4B

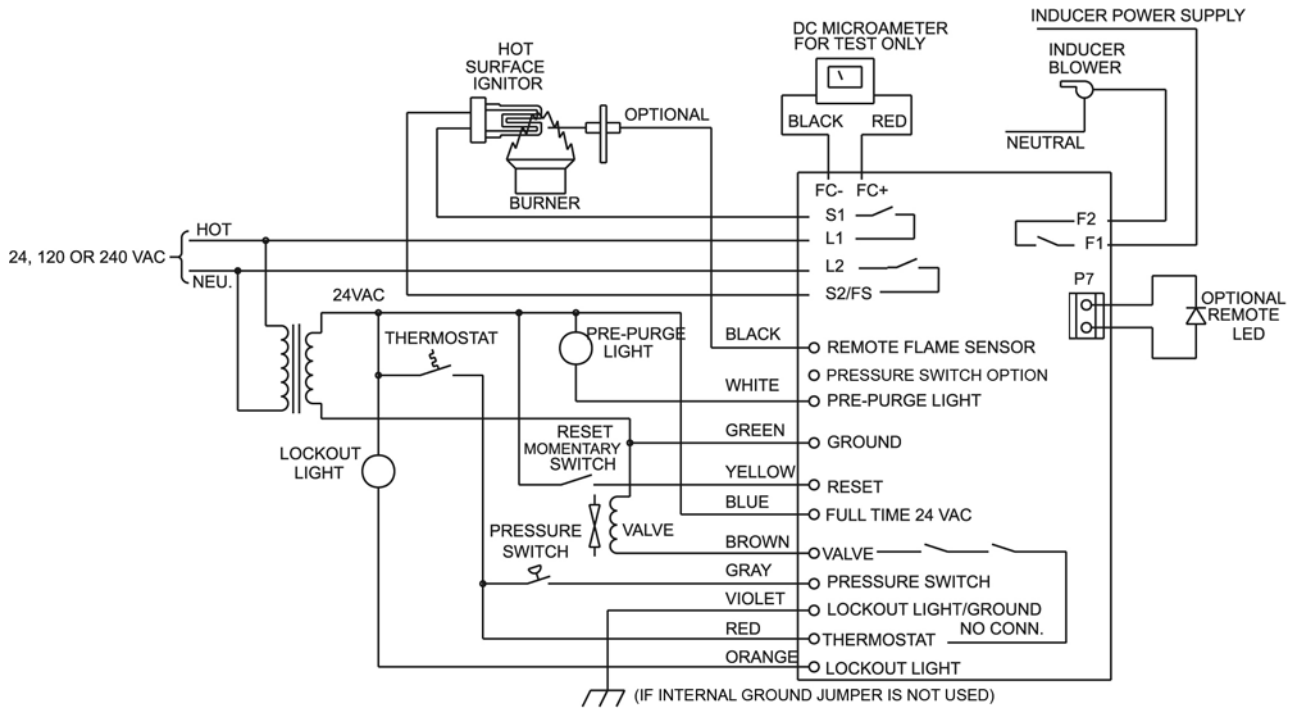

PIN LAYOUT

Figure 5B

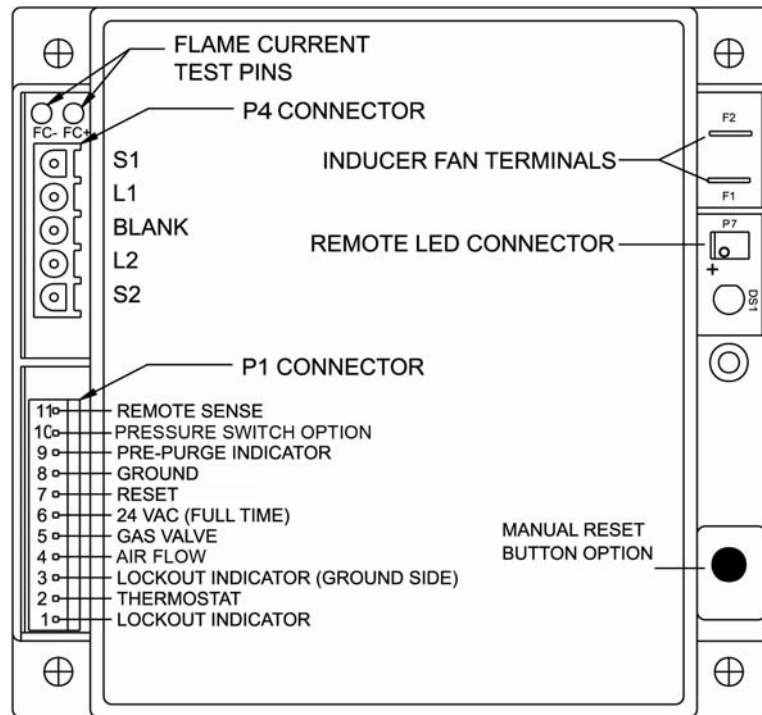

DIMENSIONS

Figure 6

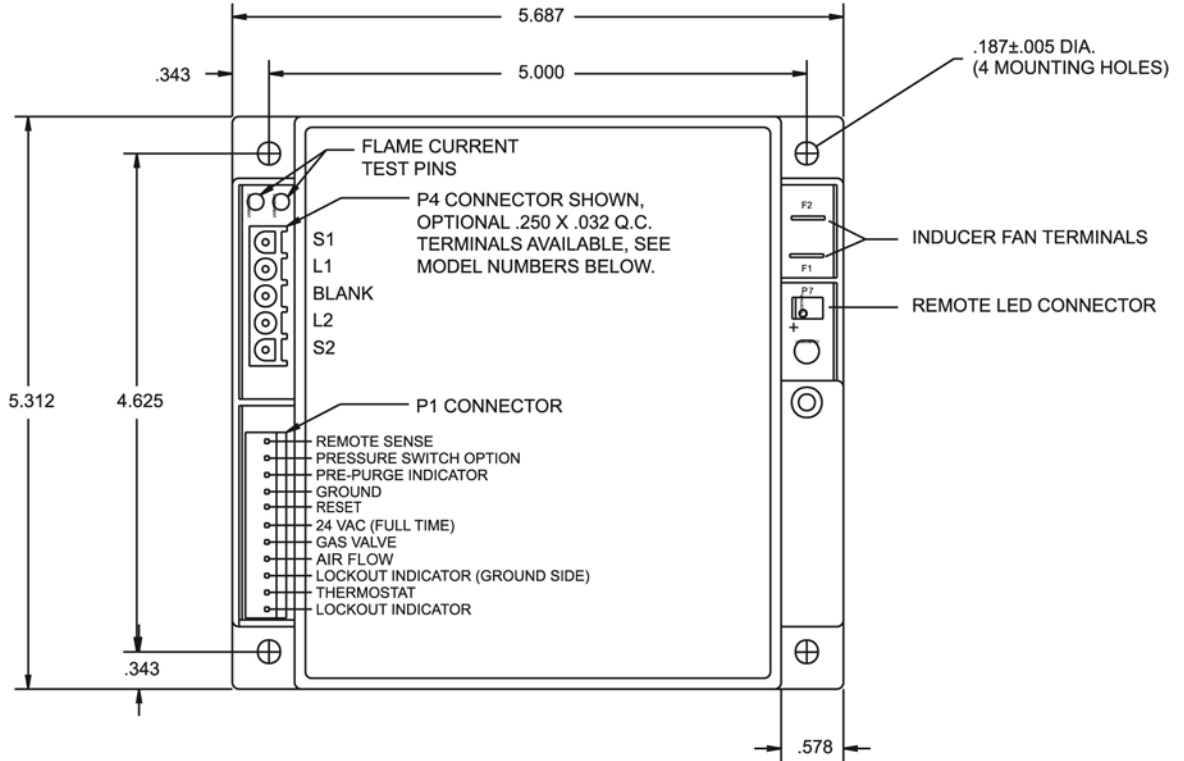

Figure 7



CONTROL CONFIGURATION

35 - 67 X X X X - X X X

Description

Trial for Ignition

- 0 = 2 Seconds
- 1 = 4 Seconds
- 3 = 7 Seconds
- 5 = 10 Seconds
- 7 = 15 Seconds

Proving Current (Amps)

- 0 = 0.8
- 1 = 0.5
- 3 = 2.1
- 4 = 2.3
- 5 = 2.7
- 6 = 3.1
- 7 = 3.3

Purge Timing

- 0 = 0 Prepurge, 0 Interpurge, 0 Postpurge
- 1 = 15 Prepurge, 15 Interpurge, 0 Postpurge
- 2 = 30 Prepurge, 30 Interpurge, 0 Postpurge
- 3 = 0 Prepurge, 15 Interpurge, 0 Postpurge (3 Try Units Only)
- 4 = 0 Prepurge, 30 Interpurge, 0 Postpurge (3 Try Units Only)
- 5 = 15 Prepurge, 15 Interpurge, 30 Postpurge (Full Time Power)
- 6 = 30 Prepurge, 30 Interpurge, 30 Postpurge (Full Time Power)
- 7 = 0 Prepurge, 15 Interpurge, 15 Postpurge (Full Time Power)
- 8 = 0 Prepurge, 30 Interpurge, 30 Postpurge (Full Time Power)

Tries For Ignition

- 0 = Single Try - Local Sense. Recycle On Flame Loss
- 1 = Single Try - Remote Sense. Recycle On Flame Loss
- 2 = Single Try - Local Sense. Lockout On Flame Loss
- 3 = Single Try - Remote Sense. Lockout On Flame Loss
- 5 = Three Tries - Local Sense. Recycle On Flame Loss
- 6 = Three Tries - Remote Sense. Recycle On Flame Loss
- 7 = Three Tries - Local Sense. Lockout On Flame Loss
- 8 = Three Tries - Remote Sense. Lockout On Flame Loss

Dwell Time

- 0 = 4 Seconds
- 1 = 6 Seconds
- 5 = 20 Seconds
- 7 = 40 Seconds

Full Time Power, Termination, Lockout Type

- 0 = No Full Time Power, Q.C. Terminals, Automatic Reset
- 1 = No Full Time Power, Mate-N-Lock, Automatic Reset
- 2 = Full Time Power, Q.C. TERMINALS, Automatic Reset
- 3 = Full Time Power, Mate-N-Lock, Automatic Reset
- 4 = No Full Time Power, Q.C. Terminals, Non-volatile Lockout
- 5 = No Full Time Power, Mate-N-Lock, Non-volatile Lockout
- 6 = Full Time Power, Q.C. Terminals, Non-volatile Lockout
- 7 = Full Time Power, Mate-N-Lock, Non-volatile Lockout
- 8 = Aftermarket Kits (Consult Factory for Special Number)
- 9 = Special OEM Features (Consult Factory for Special Number)

Other Features

- 0 = No Indicators With No Inducer
- 1 = No Indicators With Inducer
- 2 = Indicators With No Inducer
- 3 = Indicators and Inducer
- 4 = CE Approved Model
- 9 = Manual Reset (Standard Includes Indicators and Inducer)



400 MAIN STREET, ASHLAND, MA 01721
 TEL: (508) 881-2000 FAX: (508) 881-6729
 www.fenwalcontrols.com

These instructions do not purport to cover all the details or variations in the equipment described, nor do they provide for every possible contingency to be met in connection with installation, operation and maintenance. All specifications are subject to change without notice. Should further information be desired or should particular problems arise which are not covered sufficiently for the purchaser's purposes, the matter should be referred to KIDDE-FENWAL, Inc., Ashland, Massachusetts.