



MC-5000
DECEMBER 19, 2005



FIREYE MODULAR MicroM FLAME SAFEGUARD CONTROLS



WARNING: Selection of this control for a particular application should be made by a competent professional, licensed by a state or other government. Inappropriate application of this product could result in an unsafe condition hazardous to life and property.

DESCRIPTION

The Fireye MicroM Series Flame Safeguard Control is a compact, microprocessor based, modular burner management system designed to provide automatic ignition and continuous flame monitoring for commercial sizes of heating and process equipment firing any type of fuel.

The MicroM is designed to be backward compatible with existing TFM, UVM and M-Series II controls. The MicroM MEC120 and MEC230 chassis with the appropriate MEP100, MEP200 and MEP500 series programmers provide operation similar to its predecessors and is usually directly interchangeable. The MEC320 and MEC480 chassis with the appropriate MEP300, MEP400 and MEP600 series programmers provide additional enhancements such as early spark termination, pilot proving, and interrupted pilot.

The advantages of the MicroM are zero dependence on discrete components previously used for timing functions. The MicroM, through the use of micro-controller technology, incorporates smart diagnostic LED's, smart reset function for multi-burner applications, optional alpha-numeric display output (ED510), and serial communications via a Modbus or E500 Communication Interface. The MicroM system also provides additional amplifier selections. Along with the standard UV and Flame Rod amplifiers are UV self-check, Infrared, Cadmium Sulfide and a dry contact amplifier for use with the Fireye Phoenix scanner. All amplifiers are available with flame failure response times of 0.8 seconds or 3 seconds nominal (4 second maximum) and each provide a set of test jacks with a uniform range of 0-10 VDC for the measurement of flame signal intensity.

A complete MicroM system includes the appropriate flame detector, plug-in amplifier and programmer modules which connect into a standard chassis and wiring base. Interchangeable programmer and amplifier modules allow for complete versatility in selection of control function, timing and flame scanning means. Functions such as relight, recycle, non-recycle, two stage capability, non-recycle air flow, proof of air flow open at start, purge timing, early spark termination, pilot proving and pilot cutoff are determined by the appropriate programmer module. Type of flame scanner (UV, Repetitive UV Self-Check, Flame Rod, IR or Cadmium Sulfide or dry contact) and the flame failure response time (FFRT) are determined by the amplifier module. Optional plug-in daughter boards provide additional features such as remote reset, alpha-numeric display and serial communications.

The MicroM programmers are micro-controller based modules that control the sequence of operation and also interface with plug-in amplifiers, meter boards, display drivers and external communication devices. The programmers are available in an assortment of configurations necessary to resolve the application requirement. Current families of programmers for use with the MEC120 and

MEC230 type chassis include the MEP100, MEP 200 and MEP500 series. Programmers for use with the MEC320 and MEC480 type chassis include the MEP300, MEP400 and MEP600 series.

Some programmer modules are equipped with a series of dipswitches to select Purge Timing, Pilot Trial for Ignition (PTFI) timing, Proof of Air flow open at start, Post Purge, Recycle and Non-Recycle operation. LED indicators on the programmer modules indicate the current operating status of the control and during a lockout condition displays the fault as a coded sequence, simplifying the troubleshooting of a shutdown.

In the event of pilot ignition failure, or following a safety shutdown, the control locks out, activating an alarm circuit and displays the cause of lockout on the integrated LED's and on the optional ED510 display. Unless otherwise specified, manual reset is required. Remote reset is available on the MEC120R, MEC120RC, MEC320RD, MEC230RC, MEC320R, MEC320RC and MEC320RD chassis. A detailed description of the various programmer, amplifier and chassis modules is found later in this document. A "run-check" switch, provided to assist in testing size, position and stabilization of the pilot, is provided on some specific models and all MEP500 and MEP600 series programmers.

Modular MicroM controls incorporate a safety checking circuit that is operative on each start. If flame (real or simulated) is detected prior to a start or during purge, the fuel valves will not be energized and the unit will lock out.

The modular MicroM controls use the same wiring base as the Fireye UVM, TFM and M- Series II controls and are designed to be interchangeable with most models with little or no rewiring. See INSTALLATION OF CONTROL, SCANNERS AND FLAME DETECTORS (page 8 and 47) for temperature and wiring requirements.



NOTE: The individual MicroM modules, i.e. MEC chassis, MEP programmers and amplifiers are not interchangeable with M-Series II modules, i.e. MC chassis, MP programmers and amplifiers.

SPECIFICATIONS

Supply: 120 VAC (min. 102, max. 132) 50/60 Hz. (MEC1XX, MEC3XX)
230 VAC (min. 196, max. 253) 50/60 Hz. (MEC2XX, MEC4XX)

Power Consumption: 12 VA (Operating)

Shipping Weight (Approx): 3 lbs (1.4 kg)

Operating Temperature: -40°F (-40°C) to 140°F (60°C)

Table 1:

AMBIENT TEMPERATURE LIMITS

	MAXIMUM		MINIMUM	
	°F	°C	°F	°C
Control	140	60	- 40	- 40
Scanner UV1A, UV2, UV8A, 45UV3, UV90	200	93	- 40	- 40
45UV5-1007, 45UV5-1009; 55UV5-1007, -1009	200	93	- 40	- 40
Photocell 45CM1 (OBSOLETE)	165	74	- 40	- 40
Flame Rod (Tip 2460 F)	1500	816	- 40	- 40
48PT2	140	60	-40	-40
CSIA5	140	60	-40	-40



Table 2: LOAD RATINGS: All Ratings are 120V, 60 Hz

Fireye Terminal	Typical Load	Maximum Rating @120V 60 Hz
3 or 4 Individual or combined	Pilot valve(s) Solenoid valve Ignition Transformer	125 VA pilot duty (solenoid valve) plus 250 VA (Transformer)
5	Main Fuel Valve(s)	125 VA pilot duty (solenoid) or 25 VA pilot duty (solenoid) and 400 VA (opening) motorized, 250 VA hold
8	Motor or contactor	Terminal 8 rated to energize and de-energize 9.8 FLA, 58.8 LRA on safety lockout.
A	Alarm	125 VA, pilot duty
Minimum load requirement = 100mA		

Table 3: ALTERNATIVE LOAD RATINGS:

COMBINATION NUMBER	PILOT FUEL TERMINAL 3	IGNITION TERMINAL 4	MAIN VALVE TERMINAL 5
1	C	NO LOAD	E
2	B	NO LOAD	E
3	NO LOAD	NO LOAD	E
4	E	A	E
5	NO LOAD	A	E
6	D	A	E
7	D	A	D
8	NO LOAD	A	D

Table 4: COMPOSITION OF EACH COMBINATION

A	B	C	D	E
4.5A Ignition	50 VA Pilot Duty plus 4.5A ignition	180 VA Ignition plus motor val- ues with: 600VA inrush., 360 VA open, 250 VA hold	2A Pilot Duty	65 VA Pilot Duty plus Motor valves with: 3850 VA in rush., 700 VA open, 250 VA hold

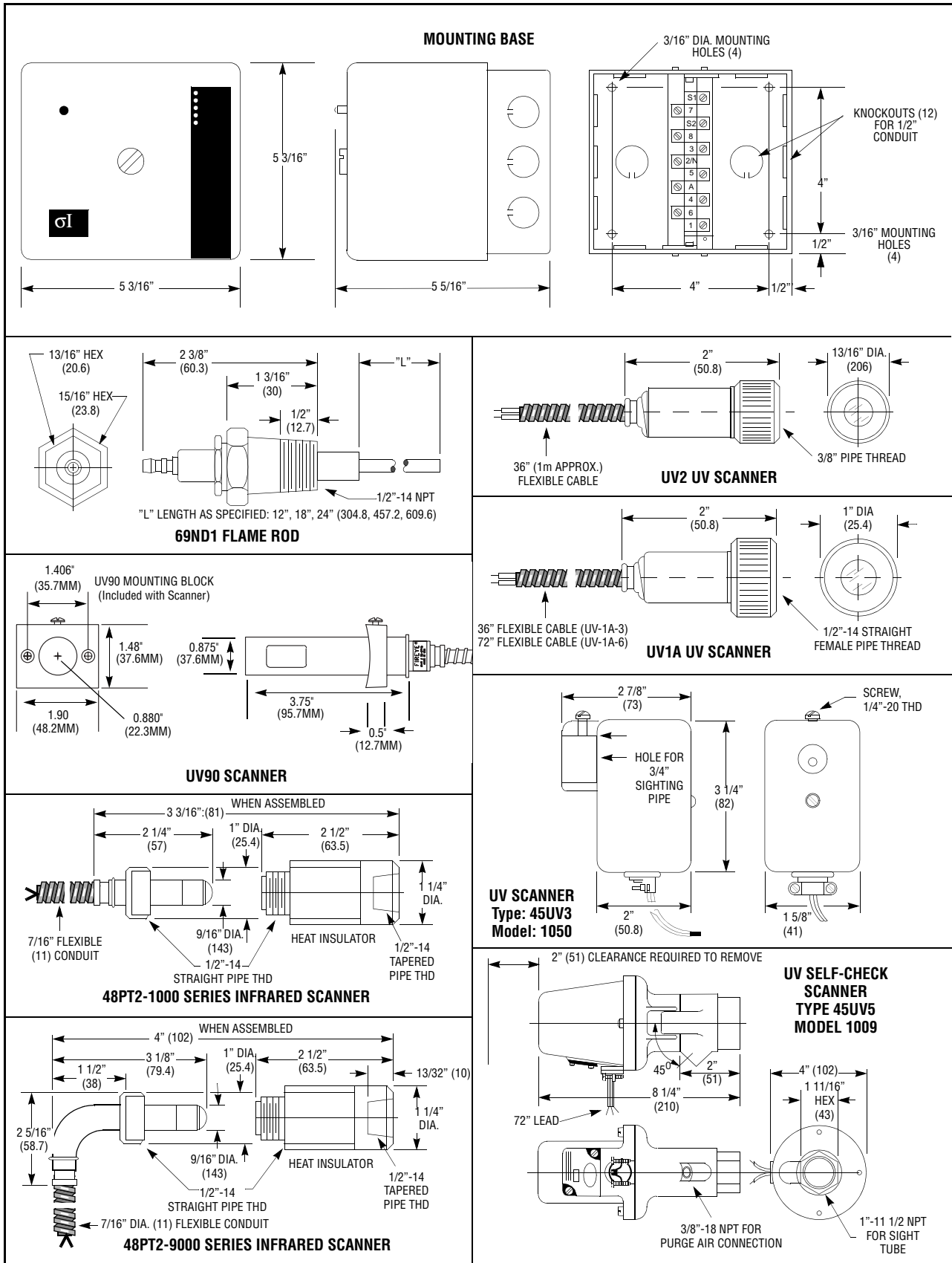

All dimensions in inches (millimeters in parentheses).



WARNING: This equipment is a Class B digital apparatus which complies with the Radio Interference Regulations, CRC c.1374.



CAUTION: Published load ratings assume that no control be required to handle inrush current more often than once in 15 seconds. The use of control switches, solenoids, relays, etc. which chatter will lead to premature failure. It is important to run through a test operation (with fuel shut off) following the tripping of a circuit breaker, a blown fuse, or any instance of chattering of any external current consuming devices.

APPROVALS

Underwriters Laboratories Inc.
Listed Guide MCCZ - File MP1537

Factory Mutual System (FM) Approved

Underwriters Laboratories Inc.
Recognized Components Guide MCCZ2
File MP1537

Canadian Standards Association
Guide 300-1-0.2 Class 2642 Oil File LR7989
Guide 140-A-2 Class 2632 Gas File LR7989

UL and CSA approval does not apply to 230VAC operations.



WARNING: Selection of programmer and amplifier type for a particular application should be made by a competent professional, such as a Boiler/Burner technician licensed by a state or government agency, engineering personnel of the burner, boiler or furnace manufacturer (OEM) or in the performance of duties based on the information from the OEM.



WARNING: This equipment generates and can radiate radio frequency energy, and if not installed and used in accordance with the instruction manual may cause interference to radio communications. It has been tested and found to comply with the limits for a Class A computing device pursuant to Subpart J of part 15 of FCC Rules, which are designed to provide reasonable protection against such interference when operated in a commercial environment. Operation of this equipment in a residential area is likely to cause interference in which case the user, at his own expense, will be equipped to take whatever measures that may be required to correct the problem.



In order for the MicroM to gather and retain statistical and historic data such as burner hours, burner cycles, system hours and average flame signal, it is necessary that Terminal 1 be powered at all times. Removing power from Terminal 1 at the end of the firing cycle causes all data gathered during the previous 16 hours or last 9 cycles to be lost. For conversions or upgrades from older TFM or M-Series II controls that use MART1 amplifiers, it is necessary that Terminal 1 be directly powered with 120 VAC.



ORDERING INFORMATION

MicroM Chassis Types (For use with MEP1XX, MEP2XX, and MEP5XX, includes dust cover)	
MEC120	120 VAC input with standard plug-in board.
MEC120R	120 VAC input with remote reset capability.
MEC120D	120 VAC input with alpha-numeric display interface to ED510.
MEC120RD	120 VAC input with alpha-numeric display interface to ED510 and remote reset capability.
MEC120C	120 VAC input with interface to E500 Communication Interface and Modbus capability.
MEC120RC	120 VAC input with remote reset capability, alpha-numeric display interface to ED510, interface to E500 Communication Interface and Modbus capability.
MEC230	230 VAC input with standard plug-in board.
MEC230RC	230 VAC input with remote reset capability, alpha-numeric display interface to ED510, and Modbus capability.

MicroM Chassis Types (For use with MEP3XX, MEP4XX, and MEP6XX, includes dust cover)	
MEC320	120 VAC input with standard plug-in board.
MEC320R	120 VAC input with remote reset capability.
MEC320D	120 VAC input with alpha-numeric display interface to ED510.
MEC320RD	120 VAC input with alpha-numeric display interface to ED510 and remote reset capability.
MEC320C	120 VAC input with interface to E500 Communication Interface and Modbus capability.
MEC320RC	120 VAC input with remote reset capability, alpha-numeric display interface to ED510, interface to E500 Communication Interface and Modbus capability.
MEC480	230 VAC input with standard plug-in board.
MEC480RC	230 VAC input with remote reset capability, alpha-numeric display interface to ED510, and Modbus capability.

MicroM Programmer Models (For use with MEC120 and MEC 230 Chassis)	
MEP100	Relight operation, 10 sec. PTFI.
MEP101	Relight operation, allow flame signal until 60 seconds after interlock closed.
MEP102	Non-recycle on flame fail, 5 second PTFI.
MEP103	Fixed 10 second SISP*, 10 second MTFI, re-try once on igniter failure, fixed 30 second post purge.
MEP104	Non-recycle on flame fail, 10 second PTFI.
MEP105	Non-recycle on flame fail, lockout on air-flow open with flame present, 10 second PTFI.
MEP106	Same as MEP100. 12 second pre-purge, added reset from lockout via line voltage.
MEP107	Same as MEP100. Force 5 minute purge delay after main flame fail.
MEP108	Same as MEP100 with 0 second purge, 15 second PTFI, non-recycle on flame fail. Not FM approved.
MEP109	Immediate ignition and pilot, 10 second fixed PTFI, 10 second MTFI, intermittent pilot, non-recycle on flame fail.
MEP100P	Relight operation, 10 sec PTFI, fixed 15 second post purge.
MEP130	Same as MEP100, 30 second PTFI. Not FM approved.
MEP230	Selectable purge timing (7, 30, 60, 90 seconds) 10 sec PTFI timing, recycle/non-recycle, post purge, prove air open at start.
MEP230H	Same as MEP230 with 8 second pilot stabilization.
MEP235	Same as MEP230 with lockout on air flow open 10 seconds after the start of a cycle, selectable recycle/nonrecycle lockout on air flow open after flame is proven and dedicated lockout after loss of flame.
MEP236	Same as MEP230 with additional 6 second igniter on time with main fuel. To be used with intermittent pilot only.
MEP237	Same as MEP230 with check/run switch. Provides operation with 85UVF4-1WR Phoenix scanner and MEDC2 amplifier.
MEP238	Same as MEP230. Ignition de-energized 3 seconds after pilot flame detected. Provides 8 second pilot stabilization period.
MEP290	Same as MEP230 except selectable post purge is 0 or 90 seconds.
MEP560	Same as MEP230H, 10 second main trial for ignition, run-check switch.
MEP561	Same as MEP560 without 8 second pilot stabilization. Selectable purge time on 7, 10, 15, 30.
MEP562	Same as MEP560, lockout on loss of air flow, non-recycle operation only.
MEP536	Same as MEP230, 10 second trial for ignition, run-check switch, will not lockout on air flow open during purge.
MEP537	Same as MEP536 except provides one recycle on main flame failure.

*Spark Igniter Sensing Period



MicroM Programmer Models (For use with MEC320 and MEC 480 Chassis)	
MEP300	Relight operation, 10 sec. fixed PTFI, 5 second pilot proving period, 5 second MTFI. lockout on flame fail during PTFI, pilot proving and MTFI. Recycle on air flow open. No post purge. Reset on line voltage.
MEP304	Non-recycle on flame fail, 5 second purge, 10 second fixed PTFI, 5 second pilot proving, 10 second MTFI, interrupted pilot, early spark termination.
MEP397	Recycle on main flame fail, 15 second purge, 7 second fixed PTFI, 5 second pilot proving 5 second MTFI, early spark termination and interrupted pilot. Recycle on air flow failure. No post purge, run/check switch. Reset on line voltage.

MicroM Amplifier Models:	
MEUV1	UV amplifier, 0.8 second FFRT, uses UV1A, UV2, UV8A, UV90 and 45UV3-1050 scanners.
MEUV4	UV amplifier, 3 second FFRT, uses UV1A, UV2, UV8A, UV90 and 45UV3-1050 scanners.
MEUVS1	UV Self-Check amplifier, 0.8 second FFRT, uses 45UV5-1009 scanner.
MEUVS4	UV Self-Check amplifier, 3 second FFRT, uses 45UV5-1009 scanner.
MERT1	Flame Rod amplifier, 0.8 second FFRT, uses 69ND1.
MERT4	Flame Rod amplifier, 3 second FFRT, uses 69ND1.
MEIR1	Infrared amplifier, 0.8 second FFRT, uses 48PT2 scanner.
MEIR4	Infrared amplifier, 3 second FFRT, uses 48PT2 scanner.
MECD1	Cadmium sulfide amplifier, 0.8 second FFRT, uses CS1A5 scanner.
MECD4	Cadmium sulfide amplifier, 3 second FFRT, uses CS1A5 scanner.
MEDC2	Dry contact amplifier, for use with MEP237.

Optional Plug-In Board Modules:	
MED1	Standard local reset switch.
MED2	Same as MED1 with display output.
MED3	Same as MED1 with remote reset.
MED4	Same as MED1 with display output and remote reset.
MED5	Same as MED1 with display output and communications.
MED6	Same as MED1 with display output, remote reset and communications.
MED7	Same as MED1 with communications.

Wiring Base (Common for all Controls):	
61-3060	Closed wiring base, surface mounting.
61-5042	Open wiring base, cabinet mounting.

Accessories	
ED510	Two line by 16 character, back lit LCD display with keypad.
ED580-2, -4, -8	Remote display cable with RJ45 connection in 2, 4 or 8 foot long lengths. To be used with the appropriate daughter board.
EC485	RS232/RS485 converter with power supply and RJ12 jack.
SMDK-1004	Serviceman's display kit used for diagnosing MicroM system. Consists of ED510 equipped with back plate, MED daughter board and ED580-4.
129-145-1, -2, -3	ED510 remote display mounting kit with 4', 8' or 2' cable respectively. Provides NEMA 4 protection.
IT1000	Monitoring device using cellular networks. Provides various reporting methods

FLAME SCANNERS



CAUTION: The UV1, UV2, UV8A, UV90 and 45UV3 ultra-violet flame scanners and associated amplifier modules are non self-checking UV systems and should be applied only to burners that cycle often (e.g.: a minimum of once per 12 hours) in order for the safety checking circuit to be exercised. If component checking is required during burner operation for constantly fired burners, utilize the self-checking ultra-violet flame scanners (45UV5) with associated amplifier module (MEUVS1, MEUVS4) or the infrared flame scanner (48PT2) with associated AutoCheck amplifier (MEIR1, MEIR4).

For a complete system, choose one of each of the following:

- Chassis
- Flame Detector
- Programmer Module
- Wiring Base
- Amplifier Module



WARNING: Installer must be trained and qualified. Follow the burner manufacturers instructions, if supplied. Otherwise, proceed as follows:

INSTALLATION OF CONTROL, SCANNERS AND FLAME DETECTORS

Wiring Base

Mount the wiring base on the burner or on a panel. The location should be free from excessive vibration and within the specified ambient temperature rating. The base may be mounted in any angular position.

All wiring should comply with applicable electrical codes, regulations and local ordinances. Use moisture resistant wire suitable for at least 90 degrees C. Good electrical wiring practice should be followed to ensure an adequate ground system. Refer to Fireye Service Note SN-100 separately and General Grounding Rules later in this document for grounding methods.

A good ground system should be provided to minimize the effects of AC quality problems. A properly designed ground system meeting all the safety requirements will ensure that any AC voltage quality problems, such as spikes, surges and impulses have a low impedance path to ground. A low impedance path to ground is required to ensure that large currents involved with any surge voltages will follow the desired path in preference to alternative paths, where extensive damage may occur to equipment.

Circuit recommendations are found on pages 38 through 43. Consult the factory for assistance with non-standard applications.



WARNING: Controls require safety limits utilizing isolated mechanical contacts. Electronic limit switches may cause erratic operation and should be avoided.



Care must be taken to NOT route the high energy ignition wire in close proximity to the flame sensor wiring, particularly when using MERT amplifier.

INSTALLING THE PROGRAMMER AND AMPLIFIER MODULES



WARNING: Remove power from the control before proceeding.

FIGURE 1.

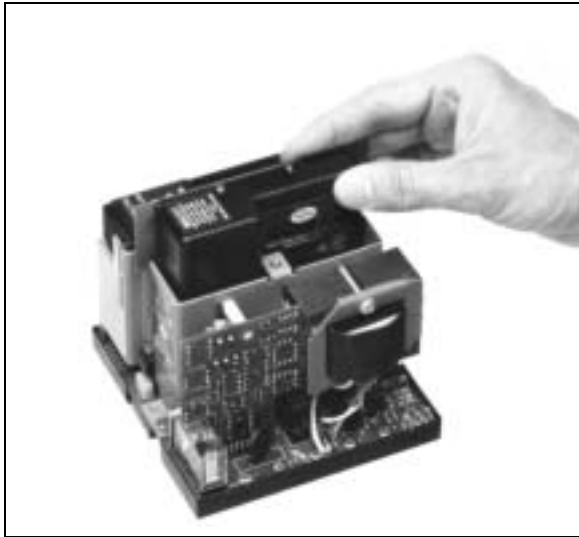

AMPLIFIER

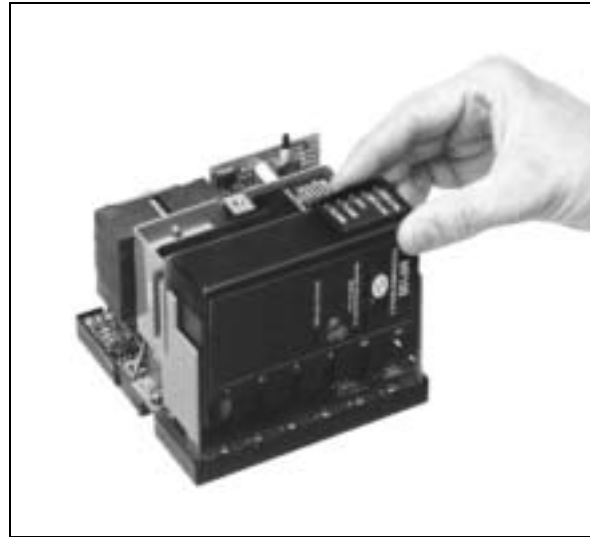

PROGRAMMER

Select the appropriate programmer and amplifier modules for your application. Remove the dust cover from the chassis. Insert the amplifier module into the slot in the corner of the chassis and gently push the module into position. Insert the programmer module into the slot at the right side of the chassis and gently push the module into position.

NOTE: Refer to programmer dipswitch settings on page 11 for the proper setting of the dipswitches for those programmers with this feature.



WARNING: Turn off the power when installing or removing the control.

Replaceable Fuse

The chassis modules are designed with a field replaceable fuse. The fuse is located on the printed circuit board below the transformer. In the event the fuse becomes OPEN, the Operating Control, PTFI, and Flame LED's will light. However, KL or KF (Wiring Arrangements section on pages 33 through 38) will not be energized and the control will lock out and indicate Lockout, Check Blown Fuse. The fuse will blow as a result of an overload condition on Terminals 3, 4, or 5. To replace the fuse, remove power from the system and using a small screwdriver or similar tool, install a Fireye replacement fuse (P/N 23-197) or equivalent 10 amp fuse (e.g. Wickman # 19373-071-K).

FOR MEC230, ORDER FIREYE REPLACEMENT FUSE P/N 23-198 OR EQUIVALENT 4 AMP FUSE (E.G. WICKMAN # 19373-062-K).



WARNING: Disconnect power before servicing.

FIGURE 2.

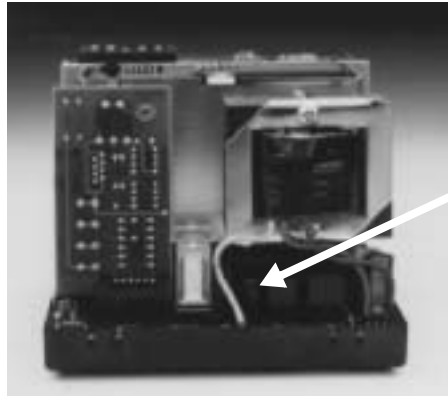

Replaceable
Fuse Location

PROGRAMMER DISPSWITCH SETTINGS

NOTE: The dipswitch settings become permanently stored within the programmer's eeprom memory after 8 hours of continuous electrical operation.

The first 8 hours of continuous operation is determined from the value of system hours being accumulated by the MicroM. System hours are stored to memory (eeprom) automatically every 1,000 minutes or at the occurrence of a lockout. Therefore, any lockout that occurs during the first 8 hours will cause the system hour value to become the time when the last lockout occurred. If power is removed and restored, the continuous 8 hours feature will be reduced by the time when the lockout occurred.

This allows sufficient opportunity to make the appropriate selection, test and checkout the system. Once stored, the settings cannot be altered.

The MEP200 and MEP500 series programmers have a series of 6 dipswitches (see Figure 3) which allow the user to program the purge timing, trial for ignition timing, enable post purge, enable proof of air flow open at start and select recycle/non-recycle operation.

MicroM Programmer Dip Switch Configuration

SWITCH						FUNCTION		NOTES
6	5	4	3	2	1			
				C	C	7	PURGE* TIME SECONDS	* The MEP561 Programmer module has selectable purge timings of 7, 10, 15 and 30 seconds.
				C	O	30		
				O	C	60		
				O	O	90		
			C			DISABLED	POST** PURGE	** The MEP290 Programmer module has selectable post purge of 90 seconds.
			O			15 SECONDS		
		C				5	PTFI TIME	
		O				10		
	C					DISABLE	PROVE AIR FLOW OPEN AT START	
	O					ENABLE		
C						RECYCLE		
O						NON-RECYCLE		

Note: C refers to switch closed position, closed position is when the switch is toward the printed circuit board. O refers to switch open position or when the switch is moved away from the printed circuit board.

cuit board. Indicating arrow on top of programmer cover points toward closed position.

Once the switches are set, they become permanently stored after 8 hours of continuous operation or they can be manually set through the use of the optional ED510 display. Refer to the section using the optional ED510 display for detailed information.

Where applicable, each MicroM programmer is shipped with dip-switch 6 set to non-recycle on flame fail, dipswitch 4 set to 5 second PTFI time, and dipswitches 1 & 2 set to the longest purge time.

FIGURE 3.

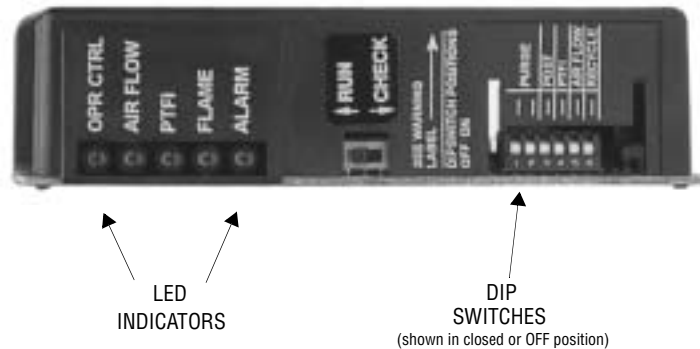

Dipswitch Definitions

Purge Time: Begins after power is detected on Terminal #7 (limit control) and Terminal #6 (running interlock switch) and no flame (real or simulated) is detected.

Post Purge: If enabled, Terminal #8 (blower motor or contactor) will remain energized for 15 seconds after terminal #7 or Terminal #6 is detected as open.

PTFI Time: The maximum length of time that Terminal #3 and Terminal #4 will be energized after the pre-purge period to detect pilot flame. For all programmers, the MicroM forces a 3 second delay before advancing to the next logic module (Stabilization, MTFI or Auto) after flame is detected during the PTFI period. This is to allow establishment of a pilot and stabilization of the fuel flow.

Prove Air Flow Open: After power is detected on Terminal #7 (limit control) and before energizing Terminal #8 (blower motor or contactor) no power must be detected on Terminal #6 (running interlock switch). If power is detected on Terminal #6, the MicroM will hold for 60 seconds after which safety lockout will occur. On recycle operation, if this is enabled, Terminal #8 will be de-energized to allow Terminal #6 to open.

Recycle / Non-Recycle: Applies to flame failure during the Run condition. If a flame failure occurs, the control will de-energize Terminals #3 and #5 and if Recycle is selected a new prepurge period will begin. Lockout will occur immediately and the alarm will energize 15 seconds after flame failure if Non-Recycle is selected. Unless otherwise stated (see Programmer Description), the MicroM recycles on all occurrences of air flow failure. The MEP235 and MEP562 will always initiate a lockout on flame failure.

LED INDICATOR LIGHTS

All MicroM Programmer Modules have 5 LED lights to indicate the operating status of the control and also to display the coded sequence under locked out conditions. The function of the lights under a normal operating condition is:

Operating Control: This LED is energized whenever the burner control switch and all other various limit switches are closed and power is applied to Terminal #7.

Interlock or Air Flow: This LED is illuminated whenever power is detected on Terminal #6, indicating the air flow switch or other running interlock is closed. If the operating control is closed and the running interlock switch remains open, this LED will flash at a 1 second rate indefinitely for the



MEP100 and MEP200 family. Lockout will occur if the switch remains open for 10 minutes in the MEP500 family. This LED will blink when configured as a flame switch and flame detected.

PTFI: This LED is illuminated only during the pilot trial for ignition period and the stabilization period when so equipped.

Flame: This LED is on whenever a flame signal is detected, and the control is not in a locked out state.

Alarm: This LED flashes when an alarm condition is detected and is used as an address indicator (see communication).

During an alarm condition, the Alarm LED is made to flash at approximately a 1 second rate. The remaining four LEDs are illuminated as a coded sequence identifying the reason for the lockout. For instance, for a LOCKOUT - FLAME FAIL- PTFI, the INTERLOCK, PTFI and FLAME LED's will all be lit steady, with the Alarm LED flashing. This remains true if power is removed and then restored in a locked out condition.

While in the Idle or Off state, the LEDs are made to flash sequentially to show the operational status of the control every minute. The LEDs can be tested by pressing and releasing the Reset push button, while in the Idle or Off state.

LOCKOUT CODES

MSGN		DESCRIPTION	OP CTRL	AIRFLOW INTLCK	PTFI	FLAME	ALARM
DEC	HEX						
6	6	Lockout Line Frequency Noise Detected	●	○	○	●	*
7	7	Lockout Flame Fail - PTFI	○	●	●	●	*
15	0F	Lockout Fault Unknown	●	●	●	●	*
16	10	Lockout Amplifier High Count Fail	○	○	○	○	*
19	13	Lockout Flame Fail - MTFI	○	○	●	●	*
20	14	Lockout False Flame - STANDBY	○	●	○	○	*
21	15	Lockout Intrlck Open	●	●	●	○	*
22	16	Lockout Intrlck Closed	○	●	●	○	*
24	18	Lockout Chassis Opto	●	●	○	●	*
37	25	Lockout Flame Fail - AUTO	○	●	○	●	*
39	27	Lockout Fuel Valve State Change	○	○	○	●	*
54	36	Lockout Check Chassis	○	○	○	●	*
55	37	Lockout Check Programmer	○	○	●	○	*
56	38	Lockout Check Amplifier	●	○	○	○	*
58	3A	Lockout Amplifier Auto Check Fail	●	○	●	○	*
59	3B	Lockout Check BLOWN FUSE	●	○	●	●	*
76	4C	Lockout Check Scanner	●	●	○	○	*
N/A	N/A	System Error	*	*	*	*	●

○ = NOT LIGHTED

● = LIGHTED

* = FLASHING

All LED's Flashing indicates defective programmer.

All MicroM chassis are shipped with a convenient peel off label that can be applied to any surface (inside cover) for future reference.



DIAGNOSTIC MESSAGES - TROUBLESHOOTING GUIDE

	POSSIBLE CAUSE	SOLUTION
Check Programmer	Voltage on Terminal 5 at improper time.	Inspect wiring to main fuel valve
	Welded watchdog relay	Replace MEC chassis
	Internal diagnostic failure	Replace MEP programmer
Check Chassis	Voltage on Terminal 3 or 4 at improper time.	Inspect wiring to pilot valve and igniter.
	Welded watchdog relay	Replace MEC chassis
Chassis Opto	Opto-Coupler(s) short circuited	Replace MEC chassis
Amplifier High Count Fail	Amplifier signal level high	Replace Amplifier module
Amplifier Auto Check Fail	Flame signal too high	Use orifice in sight pipe
	Internal Amplifier diagnostic fault	Replace Amplifier module
Check Scanner	Defective shutter	Inspect scanner wiring, replace scanner
	UV tube false firing	Replace UV tube or scanner
Check Blown Fuse	No power detected on terminal 3	Inspect defective pilot valve or igniter
	Defective fuse	Replace fuse
Line Frequency Noise Detected	Spikes detected on AC mains	Check for SCR motors or DC drives
		Inspect ground system
Fuel Value State Change	Terminal 5 (main fuel) detected on during PTFI	Check external wiring or replace MEC chassis
Check Amplifier	Amplifier not passing diagnostic tests	Replace Amplifier module
System Error	Noise transient	Check high energy ignition noise location. Be sure it is not arcing to chassis or wrapped with scanner wiring.

PROGRAMMER DESCRIPTION

For replacement of UVM, TFM and M-II type controls, refer to the cross-reference provided at the end of this section.

MEP100 SERIES

MEP100 and MEP101

These programmers provide relight operation, in the event of a flame failure, pilot trial for ignition is reinitiated. The MEP101 will not lock out if flame signal is present during the Idle or Off cycle. With flame signal present, lockout will occur 60 seconds after the start of a cycle and the air flow switch is closed.

Pilot Ignited Burners

Refer to typical wiring arrangement beginning on page 38.

Normal Operation

With power applied and the limit operating control circuit (1-7) closed, the Operating Control LED illuminates, the burner motor circuit is energized (Terminal 8).

After the air flow proving switch (7-6) closes, the interlock (air flow) LED is illuminated and a short time delay period (3-5 seconds) begins.

At the expiration of the safe start check period, a 10 second pilot trial for ignition (PTFI) period is initiated, illuminating the PTFI Led. Power is applied to Terminal 3, energizing the pilot gas valve and to Terminal 4, energizing the spark ignition.

At the detection of pilot flame, the FLAME LED is illuminated, and the programmer holds that position for 3 seconds to allow the to pilot stabilize.

Power is then applied to Terminal 5 energizing the main fuel valve and removing power from Terminal 4, turning off the spark igniter.

When the operating control opens, the control de-energizes Terminal 3 and Terminal 5 and the programmer reverts back to an Idle state.

Safety Shutdown

In the event pilot flame is not detected at the end of the 10 second PTFI period, the pilot gas valve and spark ignition are de-energized. A safety lockout occurs which de-energizes the burner motor and energizes the lockout alarm relay circuit, lighting the Alarm LED, 15 seconds after the safety lockout occurs. Manual reset is required.

In the event of a flame failure during a firing period, the main fuel valve is de-energized (Terminal 5) and the spark ignition is re-energized (Terminal 4), the PTFI period begins again as described above under Normal Operation.

In the event of the interlock switch opening, the main fuel valve and pilot valve are de-energized. The control reverts back to the Idle state and begins again a new cycle starting with the safe start check period.

Direct Spark Ignited Burners

Refer to typical wiring arrangement illustrated on page 39.

Normal Operation

With power applied and the limit operating control circuit (1-7) closed, the Operating Control LED illuminates, the burner motor circuit is energized (Terminal 8).

The interlock proving switch (7-6) closes, the INTRLCK LED is illuminated and a short time delay period (3 seconds) begins (safe start check period).

At the expiration of the safe start check period, a 10 second PTFI period is initiated. The PTFI Led is illuminated, power is applied to Terminal 3, energizing the main fuel valve and to Terminal 4, energizing the spark ignition.

At the detection of main flame, the FLAME LED is illuminated, and the programmer holds that position for 3-5 seconds to allow the main flame to stabilize.

Power is then removed from Terminal 4, turning off the spark igniter.

When the operating control opens, the control de-energizes Terminal 3 and Terminal 5 and the programmer reverts back to an Idle state. Terminal 8 is immediately de-energized.

Safety Shutdown

In the event the main flame is not detected at the end of a 10 second PTFI period, the main fuel valve and spark ignition are de-energized. A safety lockout occurs which de-energizes the burner motor and energizes the lockout alarm relay circuit, lighting the Alarm LED, 15 seconds after the safety lockout occurs. Manual reset is required.

In the event of a flame failure during a firing period, the secondary fuel valve (if used) is de-energized and the spark ignition is re-energized, the PTFI period begins again as described above under Normal Operation.

In the event of the interlock switch opening, the main fuel valve and pilot valve are de-energized. The control reverts back to the Idle state and begins again a new cycle starting with the safe start check period.

MEP102 & MEP104

The MEP102 and MEP104 programmers operate the same as the MEP100, except the PTFI time is limited to 5 seconds and 10 seconds respectively, the relight feature is eliminated and instead, the control will enter safety lockout on flame failure. Recycle to the start of safe start check period to begin a new cycle will occur on air flow switch opening.

MEP103

The MEP103 programmer implements a fixed 10 second spark igniter sensing period (SISP) used to detect spark, followed by a 10 second main trial for ignition (MTFI). Safety lockout occurs on flame failure during the main firing period (AUTO). Recycle occurs on air flow switch opening. If spark is not detected during the spark igniter sensing period the control makes one attempt to establish pilot

following a post purge of 30 seconds and a safe start check. Failure to ignition spark on the second attempt results in safety lockout.

MEP100P

The MEP100P programmers provides a fixed 15 second post purge period upon detection of the operating Control (1-7) or Air Flow switch (7-6) opening.

MEP100 as FLAME SWITCH (refer to Figure 11)

For systems that require flame switch operation, that is, relay KF will toggle on with flame signal and off without flame signal, the MicroM provides this function when equipped with an MEP100 programmer. To operate as a flame switch, Terminals 1 and 6 **MUST** be powered with 120 VAC while Terminal 7 **MUST** be left unpowered. Terminals 3, 4, and 5 will provide an isolated (KL relay not energized) set of contacts with Terminal 3 being the common input, Terminal 4 will be normally closed and Terminal 5 will be normally open. **If Terminal 7 is powered or if Terminal 6 is non-powered and a flame signal is present, the MicroM will lockout after 1 minute and Terminals 4 and 5 will no longer switch with flame signal.** Refer to Figure 11 for configuration wiring. Air Flow LED will blink while flame is detected.

TIMING CHART

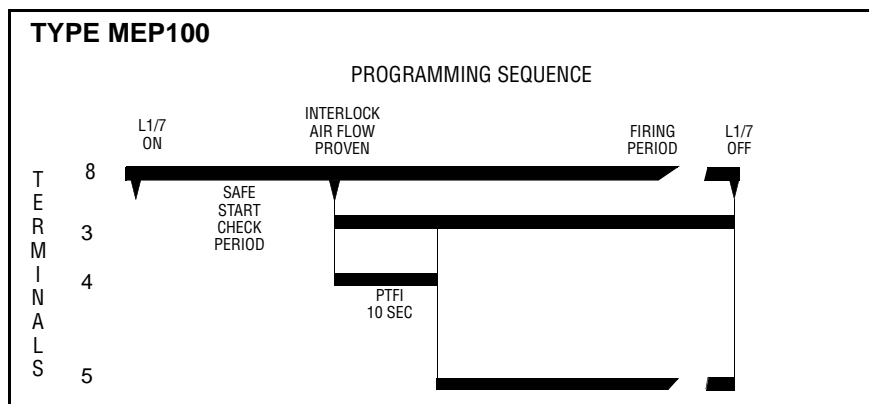

Terminal #5 is energized 3 seconds after flame is detected.
 Re-ignited PTFI on flame fail after Terminal 5 energized.
 Recycle on loss of interlock (air flow) after flame proven.

MEP101

Same as MEP100 but will tolerate flame signal during “Off” cycle.

MEP102

PTFI time limited to 5 seconds, lockout on flame fail.

MEP104

PTFI time limited to 10 seconds, lockout on flame fail.

MEP200 SERIES

The MEP200 Series programmers come equipped with a bank of dipswitches that allow user selectable prepurge timing, selectable PTFI timing, selectable post purge, selectable air flow proven open at start, and selectable recycle/non-recycle operation. Refer to PROGRAMMER DIPSWITCH SETTINGS for detailed information.

Recycle operation refers to flame failure during the main (AUTO) firing period. In the event of a main flame failure, power is removed from Terminal 3 and Terminal 5. If selected by the dipswitch, the control will enter a post purge period for 15 seconds and revert back to the Idle state where the pre-purge period begins.

If non-recycle operation is selected, in the event of a main flame failure, power is removed from Terminal 3 and Terminal 5. The control will enter a forced post purge period of 15 seconds, after which the Alarm LED is illuminated and the alarm relay is energized putting power on Terminal A.

The MEP230H programmer operates the same as the MEP230 with the exception of an additional 8 second pilot stabilization. After flame is detected during the trial for ignition period, the powering of Terminal 5 is delayed for eight (8) seconds. Terminal 4 remains powered during the stabilization period. This function is offered primarily for two-stage light oil burners, to assure a specific delay between light off of the first and second stage, and to provide additional ignition timing to improve flame stabilization.

The MEP290 programmer operates the same as the MEP230 with the exception that post purge is selectable from 0 to 90 seconds.

MEP235

The MEP235 programmer operates the same as the MEP230 except flame failure during the firing period causes lockout. Dipswitch #6 refers to Recycle/Non-Recycle on a loss of air flow (Terminal 6) after flame is proven. The running interlock circuit (Terminal 6) must be proven closed within 10 seconds after start of a cycle.

MEP236

The MEP236 programmer provides a 3 second main flame stabilization period by keeping Terminal #4 (igniter) energized while the main fuel valve (Terminal #5) opens. The MEP236 is to be used on an intermittent pilot only.

TIMING CHARTS

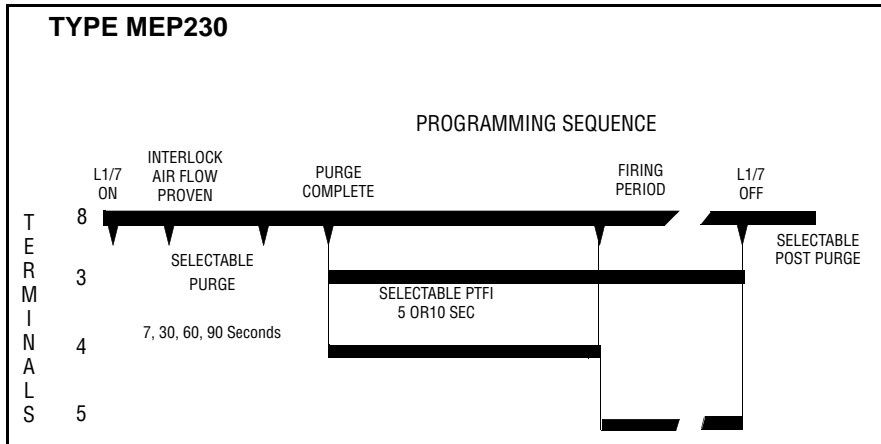

- Terminal #5 is energized 3 seconds after flame is detected.
- Selectable Recycle/Non-Recycle operation on loss of flame after Terminal 5 energized.
- Recycle on loss of interlock (air flow) after flame proven.
- Selectable air flow (interlock circuit) proven at start.
- Selectable purge times are 7, 30, 60 and 90 seconds.

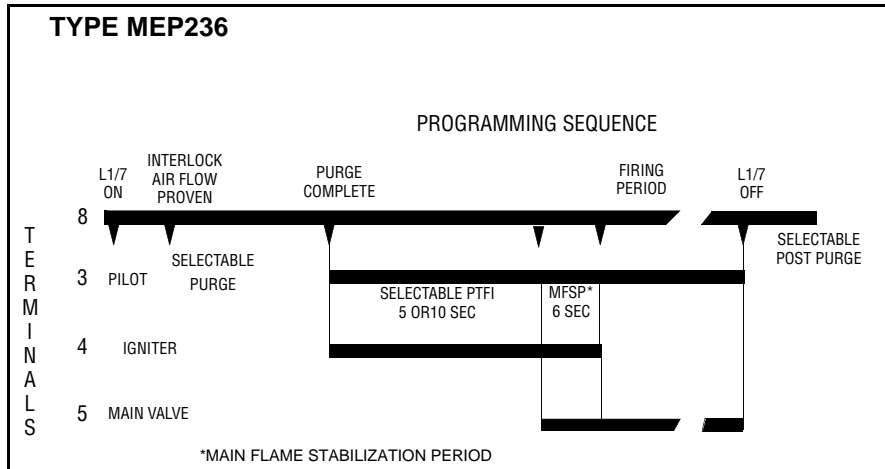

Terminal #5 is energized 3 seconds after the flame is detected.
 Selectable Recycle/Non-Recycle operation on loss of flame after flame is proven.
 Igniter remains on for 6 seconds after main valve opened.
 Intermittent pilot only.
 For interrupted pilot, use MEP536

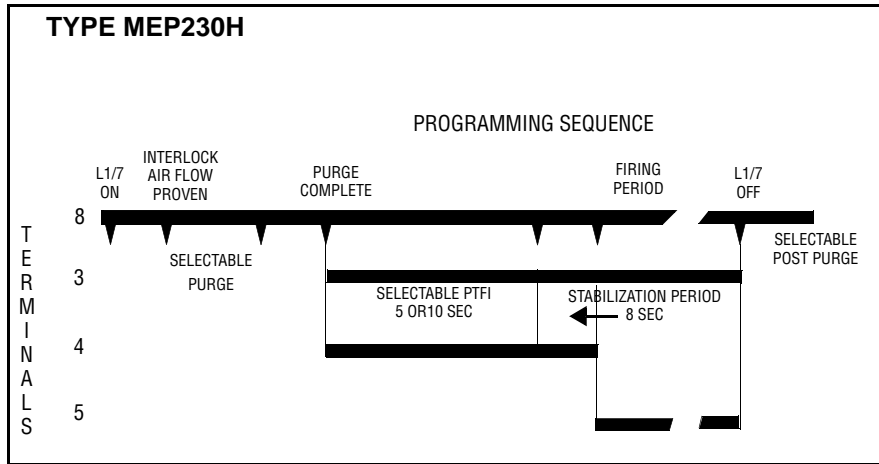

Pilot Stabilization timing begins as soon as flame is proven.
 Selectable Recycle/Non-Recycle operation on loss of flame after Terminal 5 is energized.
 Selectable air flow (interlock circuit) proven at start.

MEP500 SERIES

Refer to typical wiring arrangement illustrated on page 40.
 The MEP500 Series Programmers provide an additional relay used to control Terminal 4 separately. This allows the implementation of a pilot stabilization period as well as main trial for ignition period. They also come equipped with a bank of dipswitches that allow the user selectable prepurge timing, selectable PTFI timing, selectable post purge, selectable air flow proven open at start, and selectable recycle/non-recycle operation. Refer to PROGRAMMER DIPSWITCH SETTINGS for detailed information.

A “run-check” switch is also provided to assist in testing size, position and stabilization of pilot in conjunction with the flame detector,

For the MEP560 and MEP562, after pilot flame is detected, the control enters an 8 second pilot stabilization period with Terminal 3 and Terminal 4 energized. At the expiration of the stabilization period, Terminal 5 is energized.

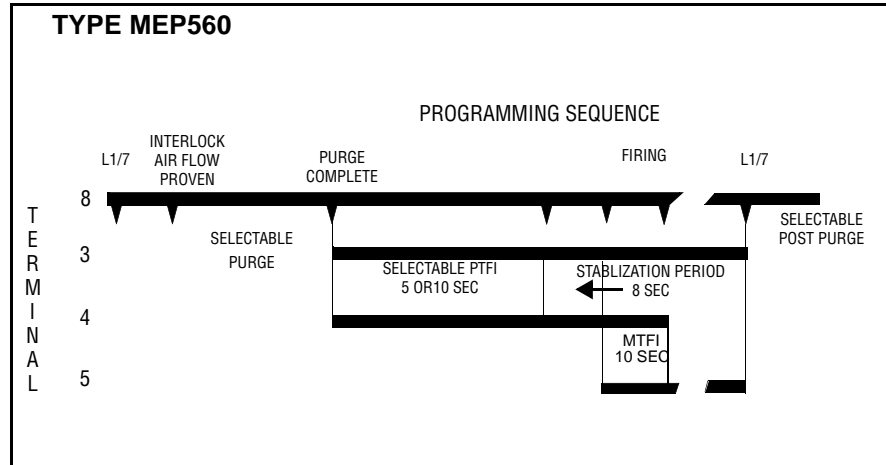

Pilot Stabilization timing begins as soon as flame is proven.

Selectable Recycle/Non-Recycle operation on loss of flame after Terminal 5 is energized.

Selectable air flow (interlock circuit) proven at start.

Recycle on loss of air flow (interlock circuit) after flame is proven.

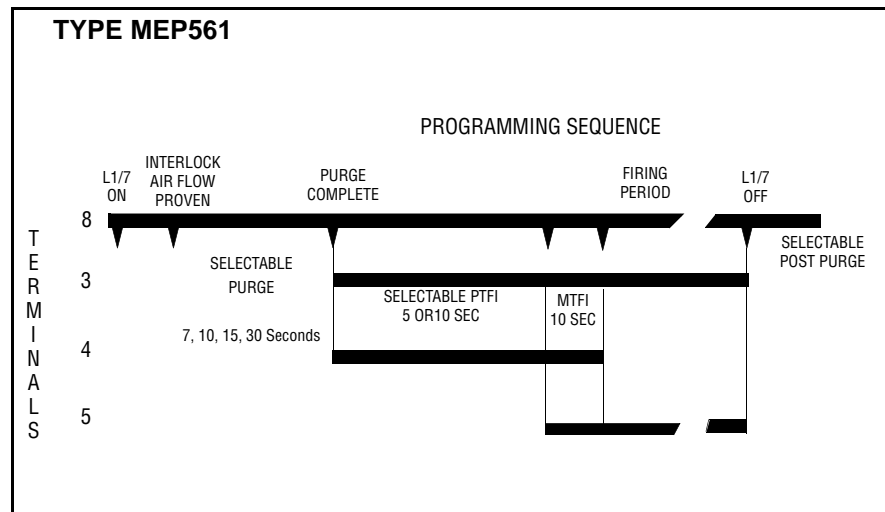

Selectable purge times are 7, 10, 15 and 30 seconds.

10 second timing begins 3 seconds after flame is proven.

Selectable Recycle/Non-Recycle operation on loss of flame after Terminal 5 is energized.

Selectable air flow (interlock circuit) proven at start.

Recycle on loss of air flow (interlock circuit) after flame is proven.

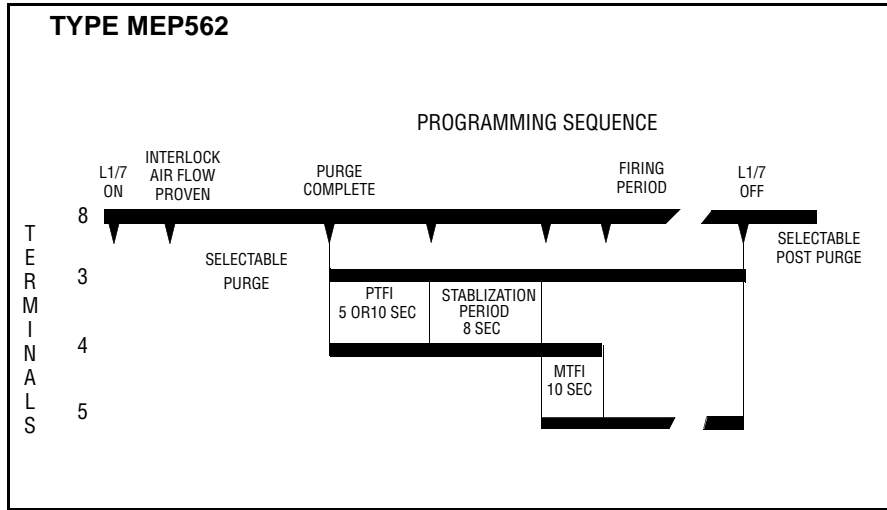

Pilot stabilization timing begins as soon as flame is proven.
 Lockout on loss of air flow (interlock circuit) after flame is proven.
 Lockout on flame fail.

MEP300 SERIES

This programmer type must be used with the MEC320 or MEC480 type chassis. Refer to typical wiring arrangement illustrated on page 41.

The MEP300 Series Programmers provide additional relays used to control Terminal 3 and 4 separately. This allows the implementation of early spark termination, pilot proving period and interrupted pilot operation. The MEP397 programmer contains a “run-check” switch to assist in testing size, position and stabilization of pilot in conjunction with the flame detector.

TIMING CHARTS

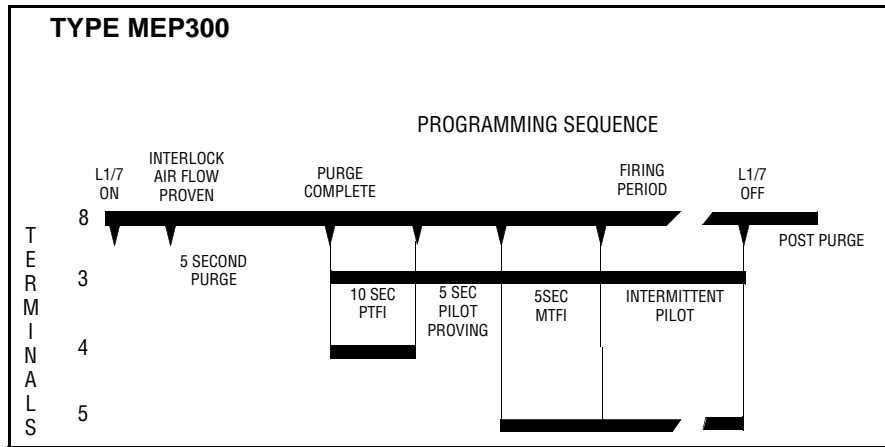

0 Second post purge on operating control open.
 15 Second post purge on flame fail during PTFI, Proving and MTFI.
 Lockout on flame fail during PTFI, Proving and MTFI.
 Relight operation on main flame fail.
 Recycle operation on air flow failure.
 Reset from lockout from pushbutton on line voltage.

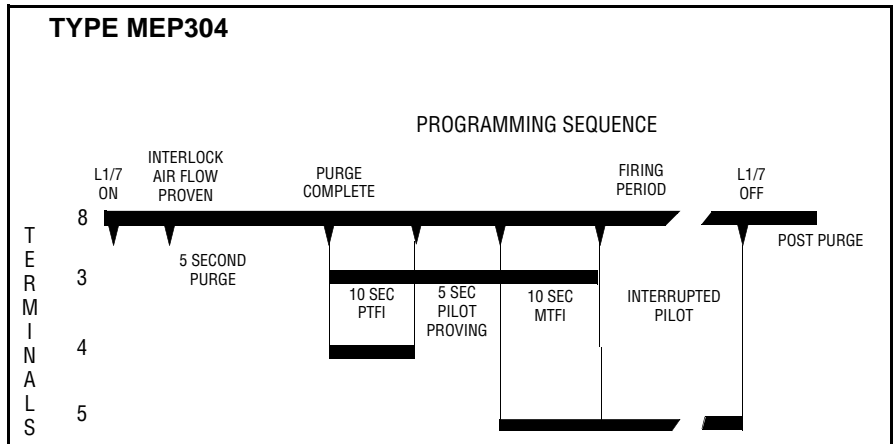

0 Second post purge on operating control open. 15 Second post purge on flame fail.
 Non-recycle operation on flame fail.
 Recycle operation on air flow failure.

CHARTS

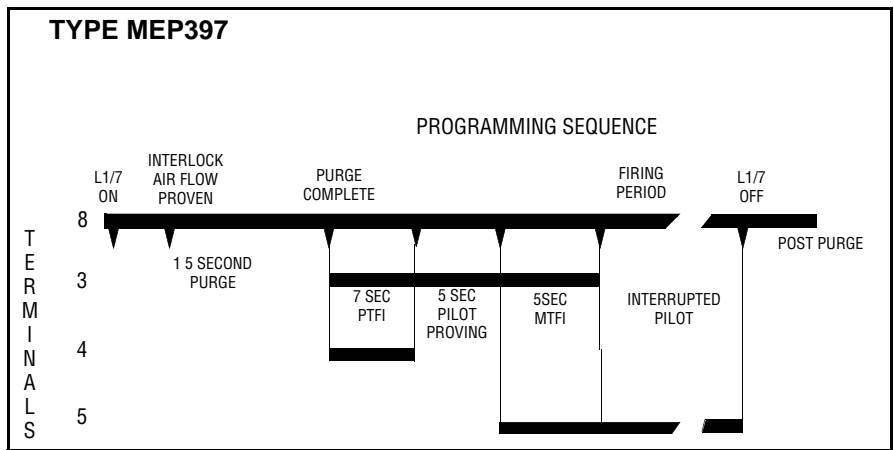

0 Second post purge on operating control open.
 15 Second post purge of flame fail during PTFI, Proving and MTFI.
 Lockout on flame fail during PTFI, Proving and MTFI.
 Relight operation on main flame fail.
 Recycle operation on air flow failure.
 Reset from lockout from pushbutton on line voltage.

OPTIONAL PLUG-IN BOARDS

Description

A family of optional plug-in boards are available separately for the MicroM chassis to provide remote reset, remote alpha-numeric display and serial communications as a stand alone or in combination. Refer to ORDERING INFORMATION for MicroM Chassis types for units that have pre-installed functions.

FIGURE 4. PLUG-IN BOARD LOCATION AND INSTALLATION

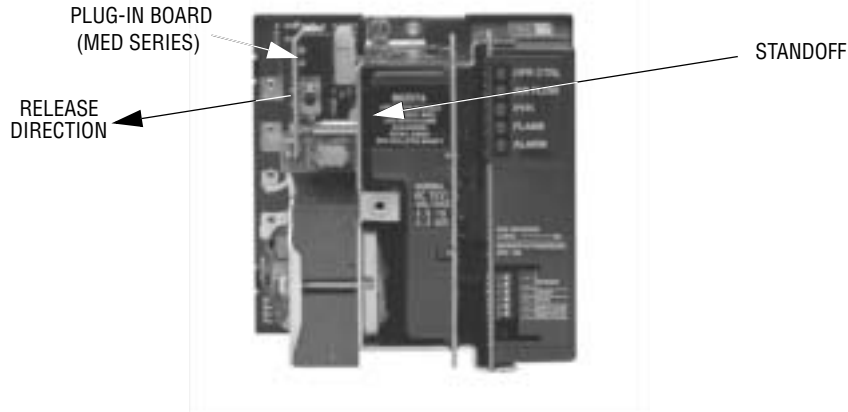

Installation



WARNING: Remove power when servicing the control.

For upgrading standard units or for replacing the installed plug-in board, grasp plug-in board at the top and pull away from the chassis, freeing the unit from the retaining standoff. Lift plug-in board up and away from connector located on chassis board. Guide new plug-in board into the same connector and push onto standoff.

Function

Remote Reset

Any MicroM chassis type with the appropriate plug-in board installed provides remote reset capabilities in the event of a lockout condition. A remote reset switch consists of a dry contact such as a remote momentary push-button wired to the two (2) terminals located on the plug-in board as shown in Figure 5. The reset switch will also force the MicroM to recycle if depressed and released during the purge or run period.

FIGURE 5. REMOTE RESET

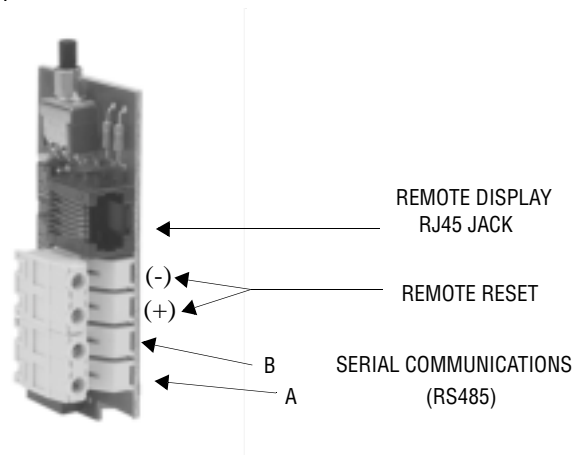



CAUTION: Remote reset is recommended only on a control solely for proved ignition programming (pilot ignited burner) or a control for use only with applications in which unburned fuel cannot accumulate and that is intended for installation in inaccessible locations such as open-flame, ceiling-suspended gas heaters. The remote reset location must be within sight and sound of the fired equipment.

ADVANCED RESET FUNCTIONS

Multiple functions have been integrated into the reset push button located on the MicroM and provided by way of the remote reset terminals. Among these are reset/recycle, reset from lockout only, recycle only and set unit address. **The functions of the switch is determined by the length of time the push button is depressed and released.**

The MicroM allows the connection of the remote resets to be connected together, usually in a multi-burner system where multiple MicroM's are mounted in a common panel. The reset push button located on the MicroM daughter board is in parallel with the remote reset terminals when provided by the other MED daughter boards.

Normal Operation

If the push button is depressed and released for greater than 1/2 second but less than 3 seconds, the MicroM will either reset if in lockout, or shutdown and revert back to the start of the cycle. If the MicroM is in the Idle state, this action will cause the LED's to sequence from the bottom to top and serves as a LED test.

Smart Reset

If the push button is depressed and released greater than 3 seconds but less than 5 seconds, the MicroM will reset from the lockout state only. This is especially useful where, through the use of remote reset daughter boards, all reset inputs can be connected together to a common reset pushbutton or intelligent device (PLC). If the push button is depressed as described above it will only cause the unit that is in lockout to reset and not effect any other units.

Smart Recycle

If the push button is depressed and released greater than 5 seconds but less than 7 seconds, all connected MicroM units will recycle back to the beginning of purge. All units that are in lockout will remain in lockout.

Address Mode

If the unit is in the Idle or Standby mode and the push button is depressed and released for greater than 10 seconds, the unit address of the MicroM will be displayed on the LED's in a binary format. The range of the address is 0 to 31 and is used for Modbus or E500 communications. Because the default address is 0 and since address 0 would mean no LED's would be lit; the ALARM LED is made to flash when the address is 0. The OP CTRL LED is the least significant bit while the FLAME relay is the most significant bit. The ALARM LED is used to indicate if the address is greater than or less than 16. If the ALARM LED is flashing, the address is less than 16 and conversely if the ALARM LED is solid, the unit address is greater than 16. This only applies to the address. To increment the address on the control, depress and release the RESET push button and observe the LED pattern. If the RESET switch is untouched for 30 seconds, the current address displayed will be stored to memory and the MicroM will automatically exit the address mode.

	LED	BINARY VALVE
OP CNTRL	○	1
INTRLCK	○	2
PTFI	○	4
FLAME	○	8
ALARM	○	16

The ALARM LED flashes for addresses less than 16.

The ALARM LED is solid for addresses greater than 15.

REMOTE DISPLAY

The MicroM provides an interface to the optional ED510 display module. The ED510 connects to the MicroM through the plug-in board using a ED580 cable. The ED580 cable is available in 2, 4, or 8 foot lengths. Part number 129-145 -1 (4 ft.), -2 (8 ft.), -3 (2 ft.) is available for remote mounting the ED510 Display Module and to provide NEMA 4 protection.

The ED510 Display Module is a backlit, 2 line by 16 character LCD display with keypad to provide both current operation and historical information of the MicroM. The ED510 contains a keypad consisting of three push keys, SCRL, RESET and MODE. Remote reset is available through the ED510 Keypad.

The ED510 displays current burner status, first out annunciation in the event of a lockout condition, historical burner information, detailed lockout information of the last six (6) lockout conditions and programmer configuration information. Through the display the ability to program the unit address for communications, as well as resetting the stored information (cycles, hours, and lockouts) to zero is provided.

Depending on the information being displayed, data is displayed on the ED510 screen in the following locations:

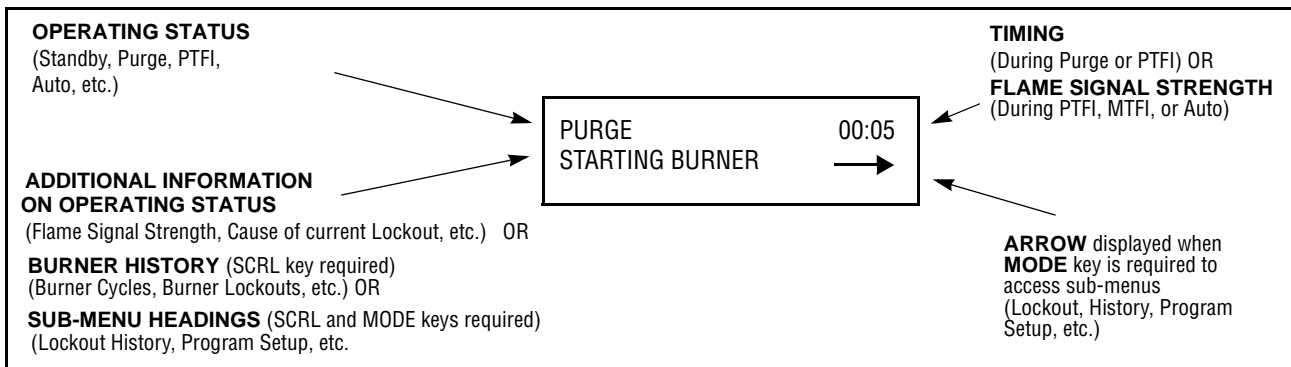

At any time the MicroM is powered, the SCRL key is used to scroll through and display the total number burner hours, burner cycles, burner lockouts and system hours on the bottom line of the ED510 display. The top line will continue to show the current run mode of the control (e.g. PURGE, AUTO, etc.) Following the historical information, the SCRL key will display three (3) sub-menus providing the following information and/or functions:

- Lockout History (with burner cycle and burner hour time stamp).
- Program Setup (to display programmer type, purge timing, switch configuration, etc.)
- System Information (values of average pilot and main flame signal, and reset burner history).

The system sub-menus require the MODE key to gain access to the information associated with each sub-menu. An arrow is displayed in the lower right hand corner of the display to indicate a system sub-menu is available. Once within the sub-menu, pressing the SCRL key displays the next item within the sub-menu, and pressing the MODE key will exit the sub-menu and return the display to the top of the main menu.

AUTO	40	Number of burner operating hours. (Terminal #5 energized).
BNR HOURS	673	

AUTO	40	Number of burner cycles.
BNR CYCLES	2784	

AUTO	40
BNR LOCKOUTS	21

Number of burner lockouts.

AUTO	40
SYS HOURS	1386

Number of hours the control has been powered.

AUTO	40
LOCKOUT HISTORY	→

Sub-menu to display the cause of the last 6 lockouts. The MODE key is required to display the actual lockouts.

AUTO	40
PROGRAM SETUP	→

Sub-menu to display various operating parameters of the programmer and amplifier. The MODE key is required to enter the sub-menu.

AUTO	40
SYSTEM INFO	→

Sub-menu to display information pertaining to the operation of the control. The MODE key is required to enter the sub-menu



LOCKOUT HISTORY

The sub-menu “LOCKOUT HISTORY” will display the last six (6) lockouts, along with the burner cycle and burner hour when the lockout occurred. When the MODE key is pressed, the screen will display the most recent lockout condition and the number of that lockout (e.g. LO #127 represents the 127th lockout of that control). The SCRL key will display the Burner Hour, followed by the Burner Cycle when the lockout occurred. The SCRL key will advance to the next lockout, and repeat the sequence listed above. The MODE key will exit the sub-menu.

PRESS	SCREEN DISPLAYS	DESCRIPTION
SCRL	AUTO 45 LOCKOUT HISTORY	Scrolling through the historical information.
MODE	LO #127 PTFI FLAME FAIL	The latest (most recent) lockout condition. This is the 127th lockout of the control. History indicates the lockout occurred during PTFI.
SCRL	LO #127 PTFI @ BNR HOURS 136	The last lockout occurred after 136 hours of burner operation.
SCRL	LO #127 PTFI @ BNR CYCLE 744	The last lockout occurred at burner cycle 744.
SCRL	LO #126 PURGE AIR FLOW OPEN	The second latest lockout condition. This is the 126th lockout of the control. History indicates the lockout occurred during purge.
MODE	AUTO 45 FLAME SIGNAL	Screen has returned to the normal run message.

PROGRAM SETUP

The sub-menu “PROGRAM SETUP” allows the user to review the various operational settings of the programmer module (e.g. programmer type, purge timing, etc.). The MODE key is used to enter the “PROGRAM SETUP” sub-menu, and the SCRL key is used to advance through the sub-menu.

MODE	AUTO 45 PROGRAMR MEP230	Programmer Type is an MEP230.
SCRL	AUTO 45 ENGR CODE NO. 5	Software Engineering code of the programmer module is code 5.
SCRL	AUTO 45 AMP. TYPE= MEUV	Amplifier module is an EUV1 or an ERT1.
SCRL	AUTO 45 FLAME FAIL TIME = 3s	Flame Failure Response Time (FFRT) is 3 seconds.
SCRL	AUTO 45 PURGE TIME = 7s	Purge timing (selected by the dipswitches) is 7 seconds.
SCRL	AUTO 45 PROVE 7-6 OPEN = N	Prove 7-6 open to start is disabled (selected by dipswitches).
SCRL	AUTO 45 POST PURGE = 0s	Post purge time is 0 seconds (selected by dipswitches).
SCRL	AUTO 45 TYPE RECYCLE	Control recycles on flame fail (selected by dipswitches).
SCRL	AUTO UNIT ADDRESS 00	Unit Address is 00. Refer to section on communications.



SCRL	PRESS RESET TO ACCEPT SETTINGS	Force storage of dipswitch settings before 8 hours time-out.
MODE	AUTO 45	Mode key returns to normal run message.

SYSTEM INFO

The sub-menu "SYSTEM INFO" allows the user to review information pertaining to the operation of the control (e.g. average main flame signal strength, status of the high fire and low fire end switches, etc.). The MODE key is used to enter the "SYSTEM INFO" sub-menu, and the SCRL key is used to advance.

Press	Screen Displays	Description
SCRL	AUTO 45 SYSTEM INFO >	SCRL key advances through the historical information until "System Info" is displayed. Pressing and releasing the MODE Key enters the sub-menu.
MODE	AUTO 45 AVG. PILOT FLM 22	The average flame signal strength of the pilot flame = 22
SCRL	AUTO 45 AVG. MAIN FLM 40	The average flame signal strength of the main flame = 40.
SCRL	PRESS RESET TO CLEAR HISTORY	Historical data will be cleared to 0. Must be done while terminal I-7 is open.
MODE	AUTO 45 FLAME SIGNAL	Mode key returns to run message.

COMMUNICATIONS

The protocol to be used is Modbus RTU. This is implemented by the master (PC, PLC, etc.) issuing a poll to the slave (MicroM) and the slave responding with the appropriate message.

A typical format of a poll request is as follows:

DST	FNC	ADR HI	ADR LO	DAT HI	DAT LO	CRC LO	CRC HI
-----	-----	-----------	-----------	-----------	-----------	-----------	-----------

DST refers to the logical address of the slave set but using reset pushbutton or ED510.

FNC is the function being requested. FNC 03 is a read request.

ADR is the message number or register number of the data being requested. In Modbus, register addresses begin at 40001 but is interpreted as address 00.

DAT is the number of words being requested. A word is an integer consisting of 2 bytes.

The normal response from a slave is as follows:

DST	FNC	DBC	DATA.... Hi/Lo	CRC LO	CRC HI
-----	-----	-----	-------------------	-----------	-----------

DBC is the data byte count being returned. It must be two times the DAT number from the poll request.

DATA is the data returned and is always a series of 2 byte integers. If 4 words were requested then DBC would be 8 and there would be 8 data bytes or 4 data words containing the requested data.

The format of the data is 4800, N, 8, 1 meaning 4800 baud, no parity, and 1 stop bit.

Below is a table of currently available messages provided by the MicroM programmers, followed by a description where necessary.

MESSAGE ADDRESS	WORDS REQUESTED	RESPONSE	VALUE
00	1-6	STATUS	83 (053H) = RUN; 202 (0CAH) = LOCKOUT
01	1	MSGN	Current message being displayed (see Table 3)
02	1	GSTAT	Defines Timer Type
03	1	TIMER	Time, Flame, Address
04	1	FLAME	Flame Signal
05	1-3	LOGSTAT	Current logic module, PURGE, PTFI, AUTO (See Table 1)
06	1	INPUTS	Input limits state
07	1	OUTPUTS	Output relays state
08	2, 4 or 8	SYSMINS	System on minutes
10	2 or 4	BNRMINS	Burner on minutes
12	2	CYCLES	Completed Burner Cycles
14	1	LOCKOUT COUNT	Stored Lockout Count
15	1-6	LOCKOUT HISTORY	Last 6 Lockouts, first word is most current lockout
21	1-2	DEVTYP	Programmer device type, 5=EP, 6=EPD, 7=MicroM
22	1	AMPTYP	Amplifier Type; MECD=080H; MEUV=090H; MEIR=0A0H; MERT=0B0H; MEUVS=0C0H
23	1	PROGTYP	Programmer Type (See Table 2)
24	2	FLAME SIGNAL AVERAGES	PTFI and Auto Flame Signal Averages
26	1-9	Combined Status	See Description Below
35	6	Most Recent Lockout Data	Returns complete lockout description of stored lockout history. Includes lockout message, lockout module, @ burner hours, and @ burner cycles
41	6	2nd Most Recent Lockout Data	
47	6	3rd Most Recent Lockout Data	
53	6	4th Most Recent Lockout Data	
59	6	5th Most Recent Lockout Data	
65	6	6th Most Recent Lockout Data	

Messages 00, 05, 08, 10, 15, 21 and 26 are unique in that a limited number of successive registers can be combined with these requests. For example, a request to message 00 can contain up to 6 data words. The response to this would contain STATUS, MSGN, GSTAT, TIMER, FLAME and LOGSTAT. If the requested data word count (DAT) were to be 2 then the response would contain STATUS and MSGN only. Message 15, last 6 lockouts, can return data ranging from 1 to 6, with 1 referring to the most recent lockout.

Message 26 returns the current operating status as well as stored burner hours and burner cycles as a snapshot of the entire MicroM system. When all 9 words are requested, the data returned consists of STATUS, MSGN, FLAME, INPUTS, OUTPUTS, BNRMINS, and BNRCYCS.

The MSGN being transmitted is a numerical value and must be interpreted by the communicating device, which actually is an advantage since this can be made to be whatever message text the end user wants. In other words, it allows for programming custom messages without actually changing the message in the programmer.

The MicroM stores its burner on time (Terminal 5 powered) and system on time (L1 powered) in minutes. Internally, the programmer converts this to hours for display purposes, however the result is rounded down. The information being supplied by Modbus will be the actual time in minutes and it is up to the communicating device to do the conversion. Since the maximum value stored in the MicroM is 9,999,999 minutes, the maximum value in hex therefore, is 98967FH and comprises of two data words. The maximum cycle count is 999,999 decimal or 0F423FH, still two data words. As an example, the System on Minutes data is transmitted from the MicroM to the interface as high word / low word as shown below:

MESSAGE ADDRESS 8		MESSAGE ADDRESS 9	
HIGH WORD		LOW WORD	
HIGH BYTE	LOW BYTE	HIGH BYTE	LOW BYTE
0	98H	96H	7FH

Note: Data from address 9 cannot be accessed directly.

All values are represented in a HEX or base 16 format.

GSTAT determines the type of value TIMER represents. TIMER can be a running timer such as is used in purge, a flame signal or meaningless. Only the lower nibble of GSTAT has any value. If this value is 0 then the TIMER value has no meaning. The value in TIMER is a background minute timer in the MicroM and should be ignored. If GSTAT is between 4 and 7, the TIMER represents the current value flame signal. If GSTAT is a 1, 2, or 3 then TIMER represents a running timer value.

The baud rate of the MicroM is fixed at 4800 bits per second. The format of the data is 8 data bits, no parity and 1 stop bit. Due to the RS485 format, the communication format is considered half-duplex. That is, only one user is permitted on the communication lines at a time.

The information contained in INPUTS and OUTPUTS represents the status of the interlocks and relays respectively. For the INPUTS, a 1 in the interlock position defines the interlock as being on or energize where the 1 in any bit position in the OUTPUT register signifies the relay as being energized.

INPUTS

			Term 5	Term 3	Term 6	Term 7	
Reset	Scrl	Mode	RF	Pilot	Intrlck	OpCntrl	Ref

Reset, Scrl and Mode represent the keypad located on the ED510 display. A '0' in any of these positions indicates the switch is depressed. A '1' in the opto-coupler position indicates the opto-coupler is on or interlock closed.

OUTPUTS

			Term 8	Term A	Term 3	Term 5	Term 4
N/A	N/A	N/A	Blower	Alarm	Pilot	Main Fuel	MTFI

A '1' in any terminal position indicates the relay is energized. Term 4 indicates the state of K1 relay, located in the MEP500 series programmers.

It is suggested that repeated polling interval not be less than 200 mSec per request. Requesting data such as burner minutes, system minutes and burner cycles be kept at a minimum due to the amount of processing time required to gather that data.

Table 1: Logic Dispatch

LOGIC DISPATCHER		
VALUE		MicroM
HEX	DEC	
45H	69	MPOSTIDLE
46H	70	MPREPURGE1
47H	71	MPURGE
48H	72	MTFI
49H	73	MSTABLE
4AH	74	MTFMF
4BH	75	MAUTO
4CH	76	MSHTDWN1
4DH	77	MSHTDWN2
4EH	78	MIDLE

Logstat represents the current software module the Flame-Monitor is currently executing. They are named as close to the logic module the actual burner sequence is in. For instance, in the Flame-Monitor, MPURGE represents High Fire Purge where MPOSTPURGE represents low fire start purge. MSHUTDWN1 represents the post purge period after a complete cycle or the cool down period after a lockout.

MIDLE or STANDBY is the period of time where the operating control is open or the control is in lockout waiting for reset. On instances of false flame during the purge period, the control algorithm forces the control back to STANDBY until false flame ceases or lockout occurs.

MPREPURGE1 is the period of time prior to PURGE where the control checks the status of the air flow interlocks or in the case of the Flame-Monitor, high fire proving switch (D-8). If found open, the control will remain in this state until the respective switch closes or lockout occurs.

MTFI represents the pilot ignition stage of a burner sequence. MTFMF represents the main trial for ignition period where main fuel is introduced along with pilot.

MAUTO is the run period of the burner sequence.

MPOSTIDLE and MSHTDWN2 are small periods of time where certain internal tests are conducted and general cleanup before and after a cycle is performed.

PROGTYP is represented by 1 data word. The upper byte identifies the family and the lower byte represents the programmer type within the family. The data represented by PROGTYP can be used to guard against the wrong programmer being installed in a system.

Table 2: Program Module Identification

Programmer Module	Identifier
MEP100	0H, 01H
MEP101	0H, 02H
MEP102	0H, 03H
MEP103	0H, 04H
MEP100P	0H, 05H
MEP109	0H, 06H
MEP130	0H, 08H
MEP104	0H, 09H
MEP105	0H, 0AH
MEP106	0H, 0BH
MEP107	0H, 0CH
MEP108	0H, 0DH
MEP230	1H, 01H
MEP230H	1H, 02H
MEP235	1H, 04H
MEP236	1H, 05H
MEP290	1H, 06H
MEP238	1H, 09H
MEP237	1H, 0AH
MEP560	2H, 01H
MEP561	2H, 02H
MEP562	2H, 03H
MEP536	2H, 04H
MEP537	2H, 05H
MEP300	0H, 01H
MEP304	0H, 09H
MEP397	0H, 0DH

Table 3: Message Description

DEC	HEX	MicroM Message
1	1	L1-7 OPEN
2	2	FALSE FLAME
3	3	STARTING BURNER
4	4	
5	5	INTRLCK OPEN
6	6	LOCKOUT LINE FREQUENCY NOISE DETECTED
7	7	LOCKOUT FLAME FAIL - PTFI
8	8	UNIT ADDRESS
9	9	MTFI
10	0AH	IGNITION TIMING
11	0BH	
12	0CH	FLAME SIGNAL
13	0DH	CYCLE COMPLETE
14	0EH	OFF
16	10H	LOCKOUT AMPLIFIER HIGH COUNT FAIL
19	13H	LOCKOUT FLAME FAIL – MTFI
20	14H	LOCKOUT FALSE FLAME – STANDBY
21	15H	LOCKOUT INTRLCK OPEN
22	16H	LOCKOUT INTRLCK CLOSED
23	17H	INTRLCK CLOSED (PROVING AIR FLOW OPEN AT START)
24	18H	LOCKOUT OPTO FAILURE
30	1EH	FALSE FLAME
37	25H	LOCKOUT FLAME FAIL - AUTO
39	27H	FUEL VALVE STATE CHANGE
40	28H	AIR FLOW CLOSED
49	31H	LOCKOUT FLAME FAIL - PTFI
54	36H	LOCKOUT CHECK CHASSIS
55	37H	LOCKOUT CHECK PROGRAMMER
56	38H	LOCKOUT CHECK AMPLIFIER
58	3AH	LOCKOUT AMPLIFIER AUTO CHECK FAIL
59	3BH	LOCKOUT CHECK BLOWN FUSE
76	4CH	LOCKOUT CHECK SCANNER

Addressing Modes

For communication in a multi-burner or multi-control environment, each MicroM must have a unique address. The range of address allowed within the MicroM is 0 to 31 allowing for a possible 32 units to be connected in a single multi-drop node. As shipped the default address is 0. The address of the MicroM may be set using two methods. Using the ED510 display, it is necessary is SCRL to the PROGRAM SETUP menu and enter that submenu with the MODE key. SCRL down until the display indicates UNIT ADDRESS with the actual address of the MicroM being displayed on the top line of the display. Pressing and releasing the RESET key will cause the address to increment. The

address after 31 is 0. The second method is to use the local reset located on the plug-in board. It is first necessary to open the operating control (L1-7) to have the MicroM in the IDLE or STANDBY position. Depressing the reset switch for greater than 10 seconds will cause the address of the MicroM to be displayed in a binary format on the LEDs located on the programmer board. Because the default is address 0, and since address 0 would mean no LEDs would be lit; the ALARM LED is made to flash when the address is 0. The OP CTRL LED is the least significant bit while the ALARM relay is the most significant bit. To increment the address counter, depress and release the RESET push button and observe the LED pattern. If the RESET switch is untouched for 30 seconds the current address displayed will be stored to memory and the MicroM will automatically exit the address mode.

TEST JACK VOLTAGE

For all amplifiers, the MicroM provides a uniform 0-10 volt signal to represent the flame signal strength. A signal reading greater than 4 volts is considered sufficient to provide reliable operation. This same signal is also available in a numerical format on the ED510 display. The chart below correlates the test jack voltage to the numerical value. The signal clamps at 10 volts at a numerical value greater than 42 and the numerical value clamps at 80.

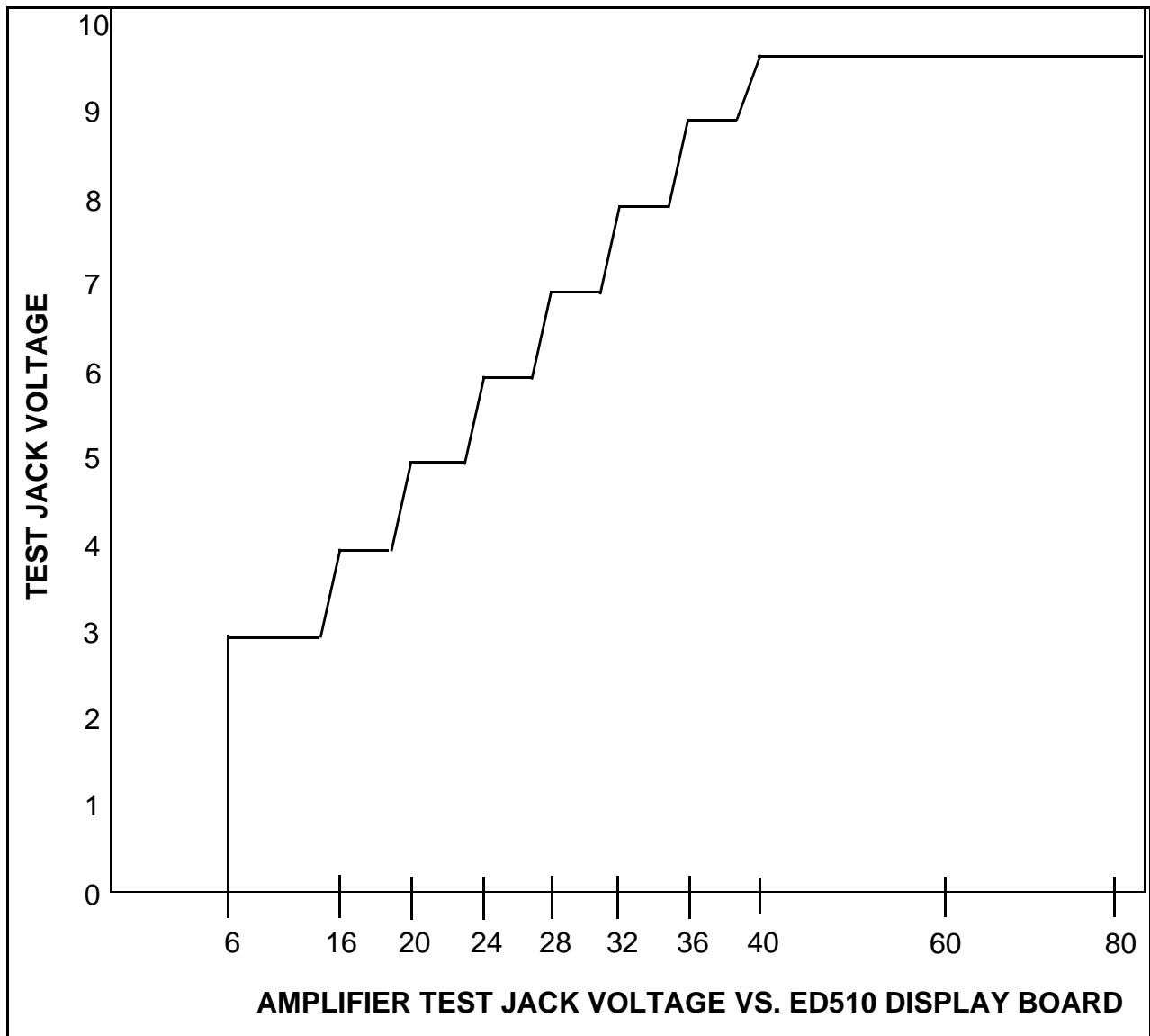

EXTERNAL METER CONNECTIONS

The test jacks are located on the amplifier card. If external access is desired for a panel meter the shown below will assist you in locating the position to drill through on the front cover. The hole sizes should be large enough to accommodate the body of the meter probes. The tests accept meter probes up to .080" or 2mm diameter.

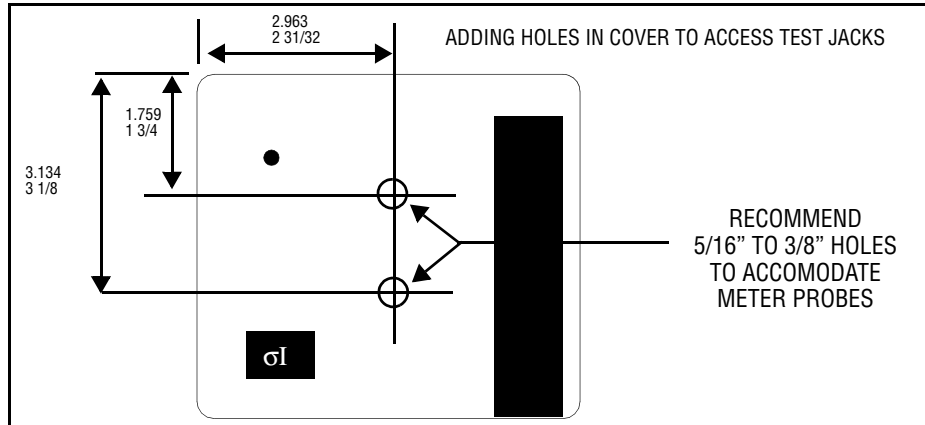

INSTALLATION TESTING

Use of Test Meter (All Controls)

Testing the Fireye MicroM Controls requires the use of a test AC/DC multimeter, with a minimum 1000 ohm/volt AC scale and 20,000 ohm/volt DC scale.

With the test meter on the DC scale, and the test meter leads inserted into the test jacks on the amplifier (Red for positive (+) polarity, Black for minus (-) polarity), a DC voltage reading of 4.0 to 10 volts for all amplifier types should be obtained when the control is detecting flame and 0 volts when no flame is present. Wildly fluctuating readings are an indication of an unstable flame or flame sensor requiring maintenance. Inadequate flame signal may be improved by:

1. Assuring that the flame detector and wiring installations have followed the instructions beginning on page 47.
2. Assuring that the flame detector is clean and within the ambient temperature limits.
3. Assuring that the flame is sufficiently large to detect.
4. Assuring that the flame quality (fuel to air ratio, combustion air velocity) is satisfactory.
5. Trying a shorter sight pipe or increasing the sight pipe diameter. **(The burner manufacturer should be consulted before mechanical changes are made).**

When using a flame rectification amplifier, a micro-ammeter may be connected in series with the wire to Terminal S2. Normal flame will produce a meter reading between 4 and 10 micro-amps.

With the test meter on the AC scale, line and load voltages may be measured at the identified test points on the chassis.



WARNING: Before making a pilot flame test, manually shut off the fuel supply to the main burner.

Normal Pilot Flame Test (Programmers with Run/Check Switch)

1. At pilot trial for ignition (PTFI) place the Run/Check switch in the Check position.
2. During the pilot flame test and adjustment period, if flame is not detected within 30 seconds, the control will lock out and require manual reset to initiate another cycle.

3. Observe the pilot flame signal on the test meter or the ED510 display. If the flame signal is below 4.0 volts DC or a reading of 10 on a remote display, re-adjust the pilot flame or realign the flame detector.



WARNING: DO NOT TOUCH a flame rectification rod with power applied.

4. When using UV detection, a test is required to verify that UV radiation from the ignition spark is not being detected. To accomplish this, manually shut off both the pilot and main fuels. Initiate a normal start-up. Observe the test meter which should read no more than 1/2 volt DC. If higher levels are observed, realign the UV scanner, and/or shield the spark from the scanner's view.
5. Move the Run/Check switch to the Run position, check pilot flame response time by manually shutting off the pilot fuel and initiate a normal start-up. With no pilot flame present, the control will de-energize the pilot assembly at the end of the trial for ignition interval (selectable by dipswitch #4) and go into safety shutdown.



WARNING: The minimum pilot test must be accomplished by a trained and qualified burner technician.

Minimum Pilot Test

This test assures that the flame detector will not sense a pilot flame too small to light the main flame reliably. It must be made on every new installation as well as following the repositioning or replacement of the flame detector. This procedure should not be used on a direct spark burner.

1. Manually shut off the fuel to the main burner.
2. Place the Run/Check switch in the Check position. (MEP500 Series Programmers only).
3. Connect a test meter to the test jacks on the Amplifier Module or observe the reading on the ED510 display.
4. Initiate a normal start-up.
5. Reduce the fuel to the pilot until the DC voltmeter reads 4.0 volts. This is the minimum pilot. For flame rectification the flame signal for minimum pilot varies depending on the application. See WARNING below.
6. Return the Run/Check switch to the Run position (MEP500 Series Programmers only).
7. Slowly turn on the main fuel and insure the main flame lights off promptly and normally.



WARNING: If light off is delayed, shut off the power to the installation. Realign the flame detector so a larger pilot flame is required before flame is detected. Repeat this test until the main flame lights reliably with minimum pilot.

Flame Failure Test

1. Temporarily connect spark ignition and pilot to Terminal #3.
2. Initiate a normal start-up.
3. Manually shut off all fuel and observe the loss of flame signal on the test meter.
4. If flame signal does not reduce to zero within the flame failure response time of the control (FFRT determined by the selection of the amplifier), verify the UV flame detector is not actuated by the ignition spark. If spark is detected, a metallic shield or relocation of the UV detector is required.



5. IMPORTANT: When the test is completed, reconnect the spark ignition to Terminal #4.

MicroM SERVICE GUIDE

SITUATION #1 NORMAL LOCKOUT

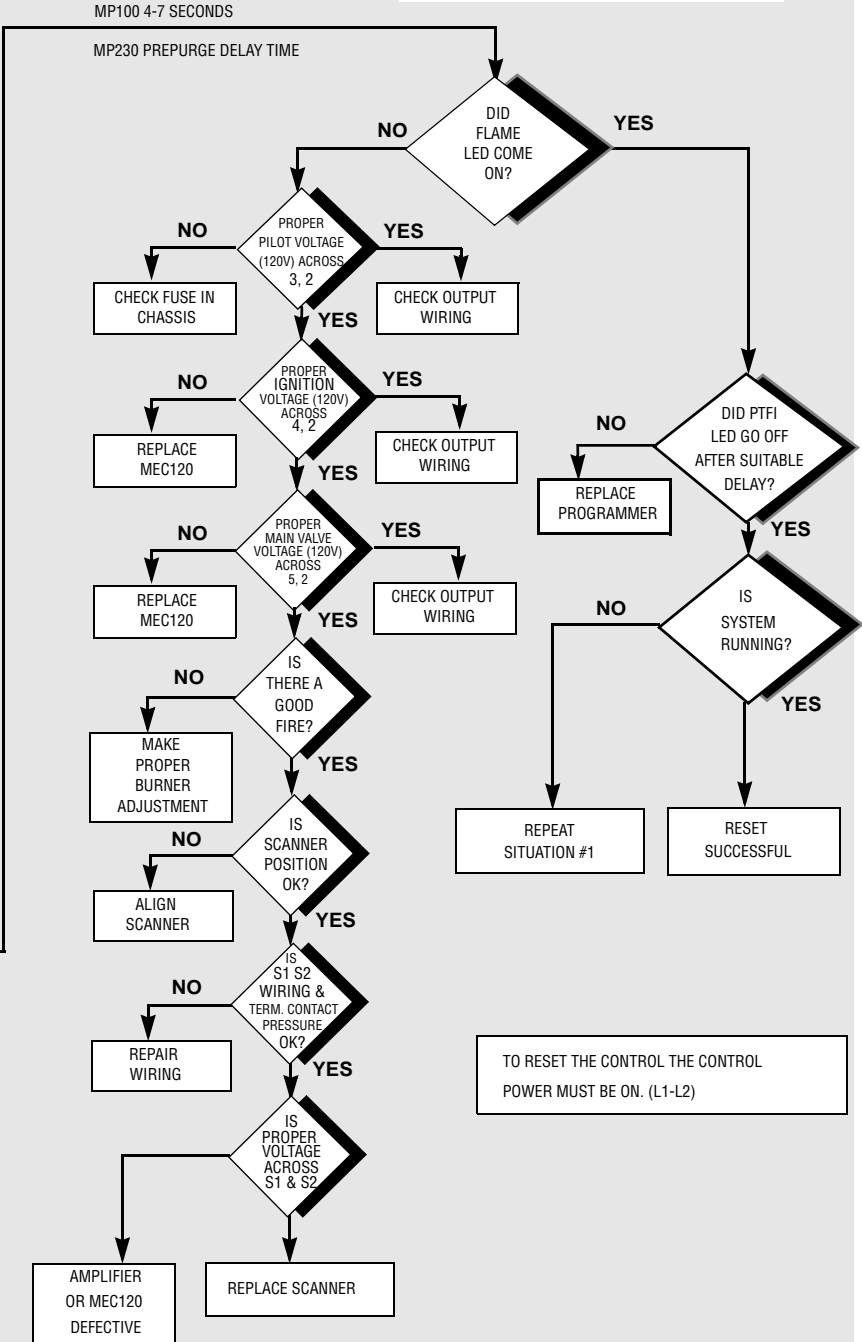
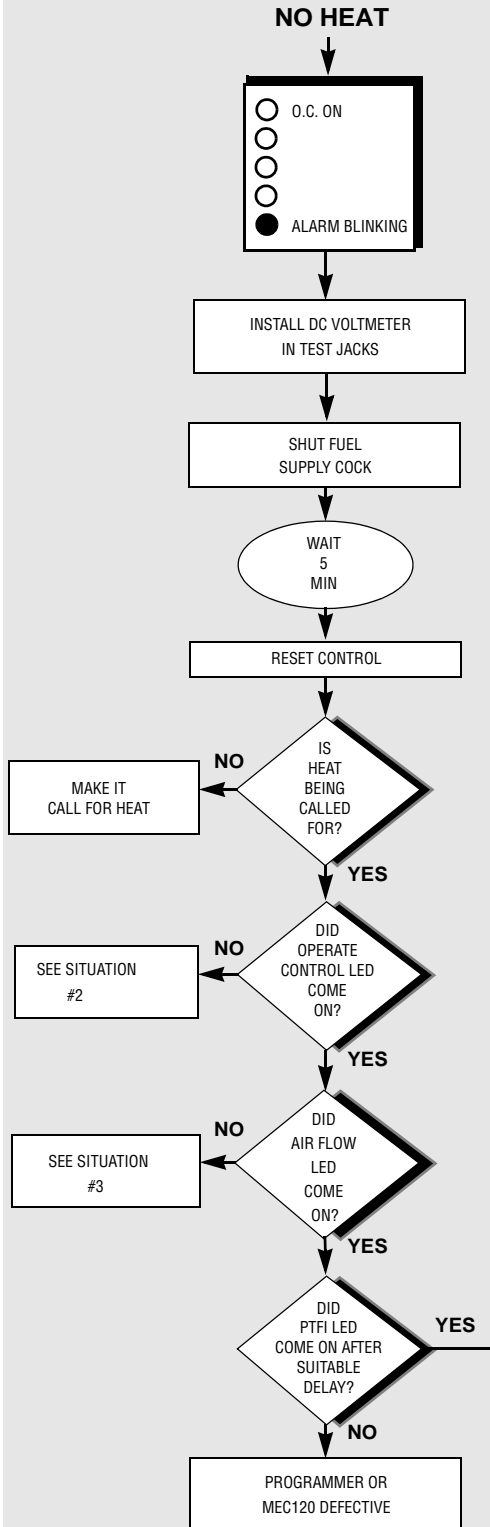
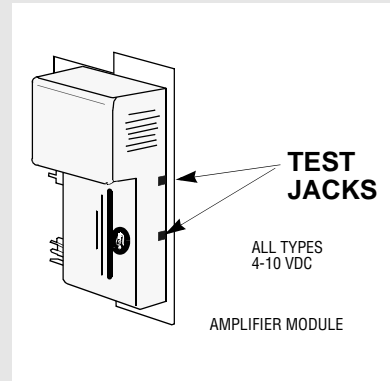

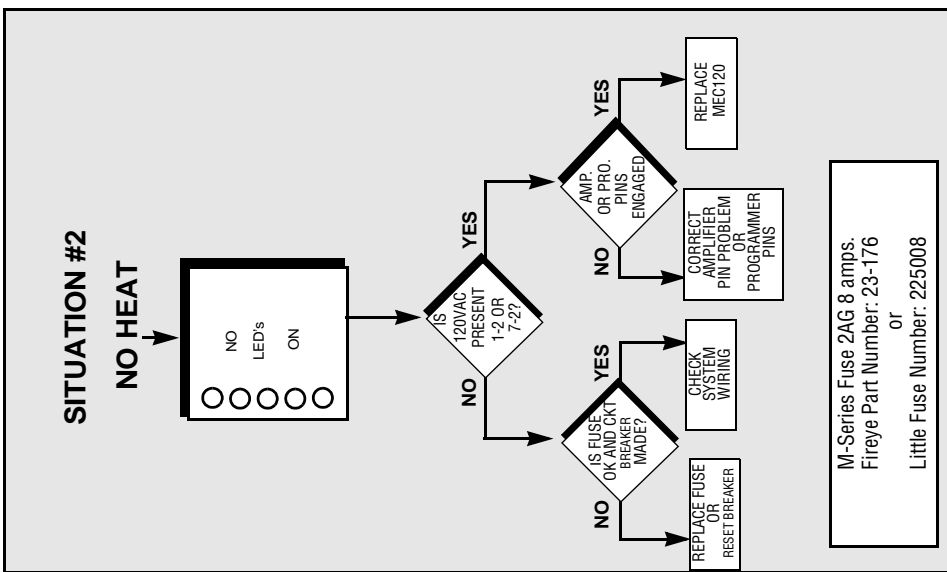
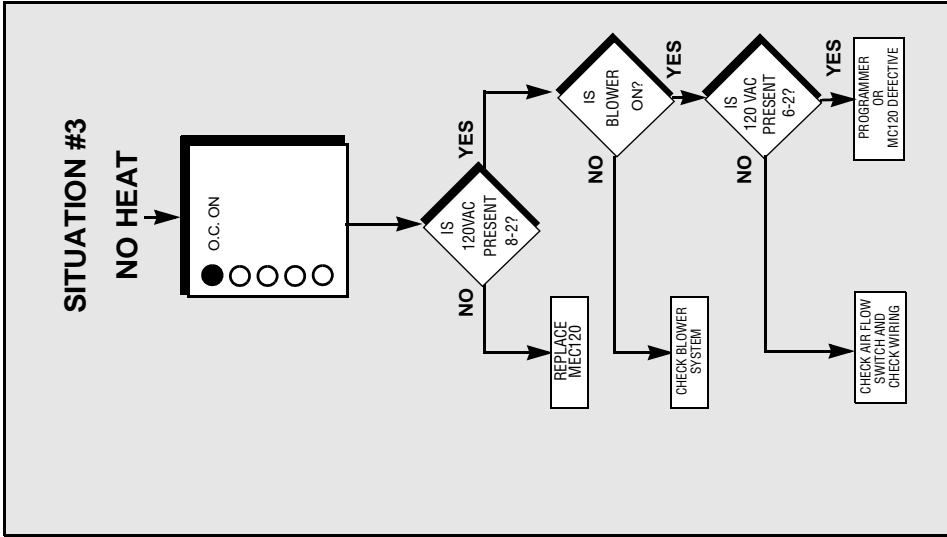
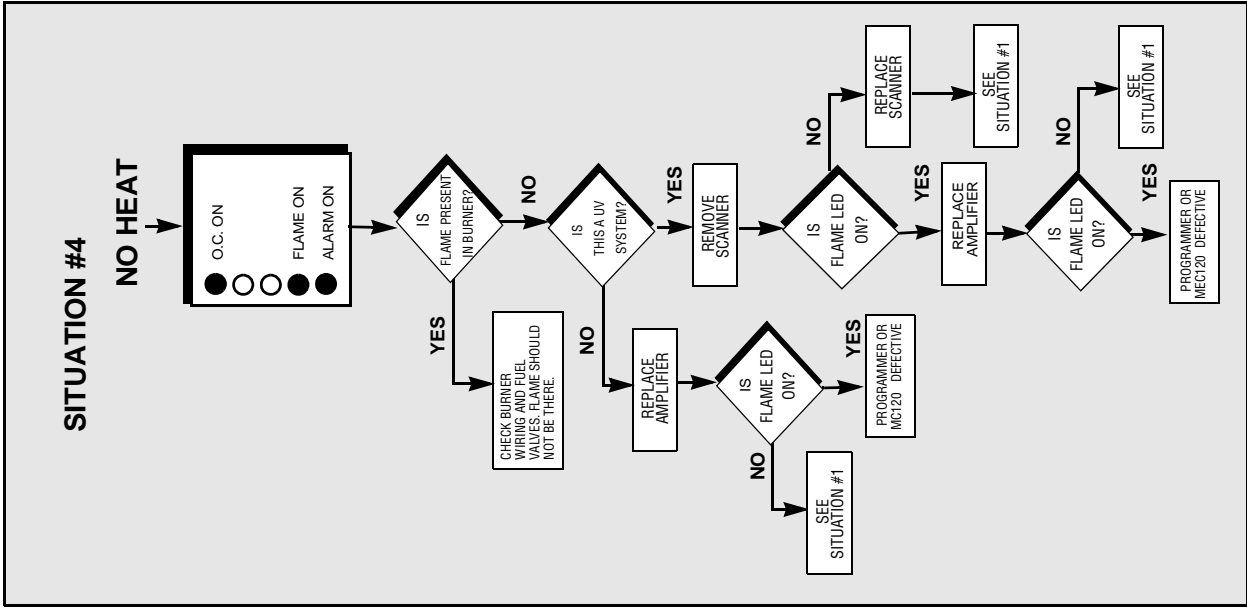

- #### TROUBLESHOOTING TIPS
1. Verify that there is a solid earth ground wire brought to the panel that the Fireye base is mounted to.
 2. In a rectification system, verify that terminal S1 is solidly earth grounded, and confirm that the flame rod is aligned so it doesn't droop near the ignition spark.
 3. Confirm that there is no measurable voltage present between the ground screw and terminal 2 (neutral).
 4. Confirm that the 120 volt AC supply has its neutral leg earth grounded at the supply, (floating isolation transformers can cause problems).
 5. Confirm that the ignition transformer's secondary winding is solidly earth grounded. The grounding method is usually through the transformer case. Dirt, paint, loose mounting hardware, etc., can all be factors.
 6. There may be a problem with transients in the main power supply. If you think this may be the problem, you may want to run a ground wire directly from the pilot assembly back to the electrical panel where the Fireye control is mounted.

Wiring Arrangements



IMPORTANT: Use moisture resistant wire rated 90°C minimum.



CAUTION: When powered, 560 VAC across S1, S2 with MEUV4, MEUV1, MEUVS4 and MEUVS1; 260 VAC across S1, S2 with MERT4 and MERT1.



CAUTION: Control wiring procedures which deviate from those shown in the diagrams may bypass safety functions designed in the control. Check with the Fireye Representative before deviating from the recommended wiring diagrams.

FIGURE 6. WIRING ARRANGEMENT FOR PILOT IGNITED BURNERS USING MEP100 AND MEP200 SERIES PROGRAMMERS

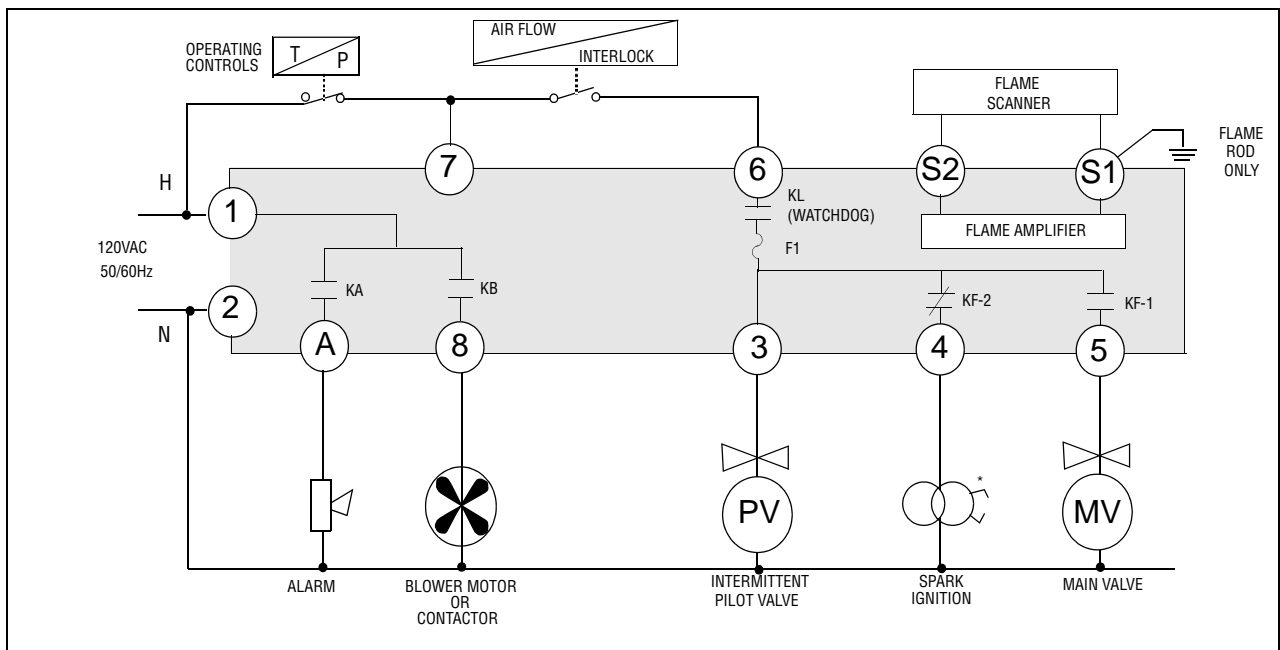

*For intermittent ignition, connect to terminal 3

FIGURE 7. WIRING ARRANGEMENT FOR PILOT IGNITED BURNERS AND PROVISION FOR MAIN FLAME STABILIZATION USING MEP236 SERIES PROGRAMMERS

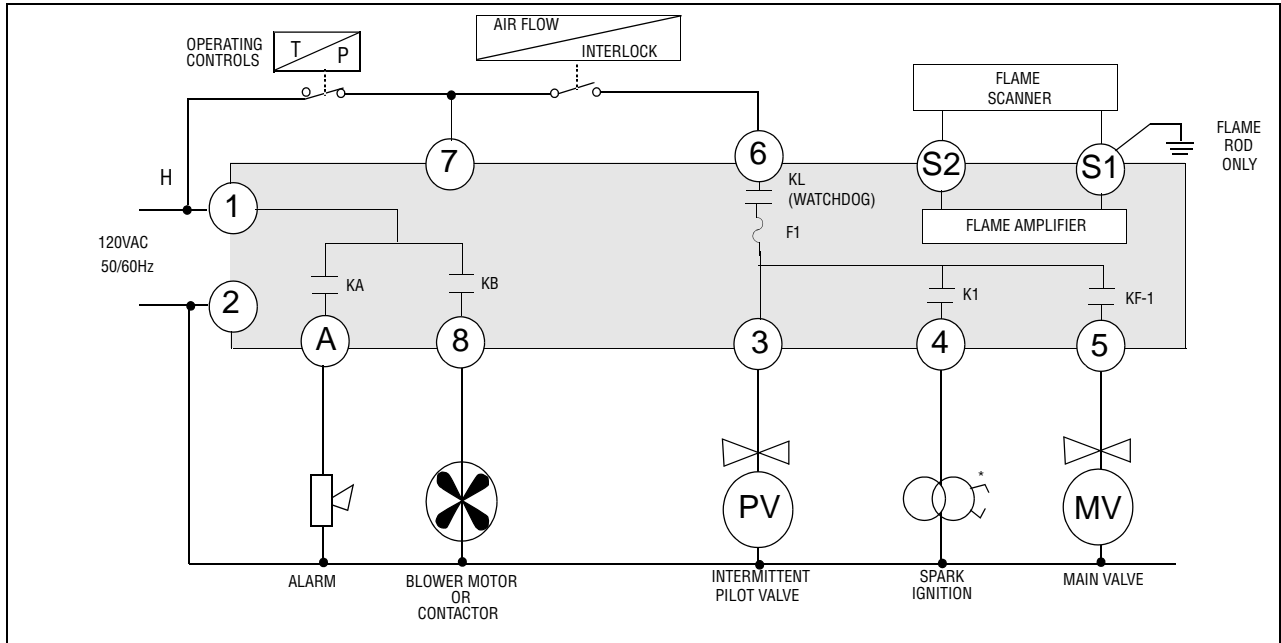
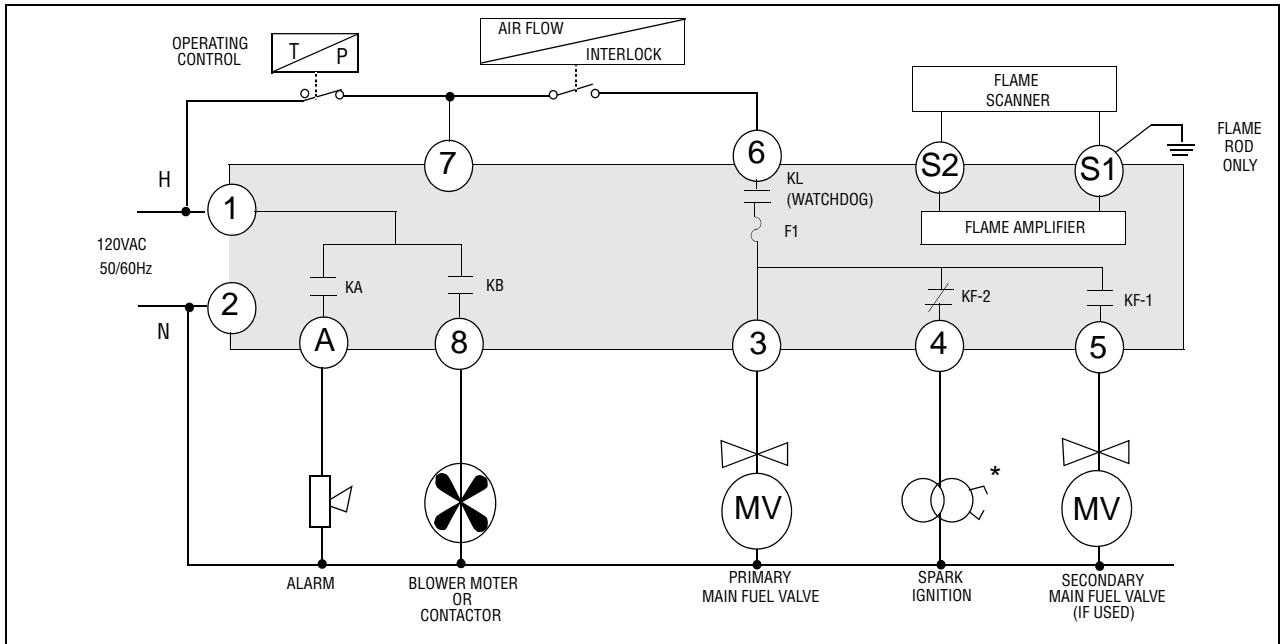

FIGURE 8. WIRING ARRANGEMENT FOR DIRECT SPARK IGNITED BURNERS, TWO STAGE OPERATION USING MEP100 AND MEP200 SERIES PROGRAMMERS



*For intermittent ignition, connect to terminal 3

FIGURE 9. WIRING ARRANGEMENT FOR PILOT IGNITED BURNERS AND INTERRUPTED PILOT USING MEP500 SERIES PROGRAMMERS

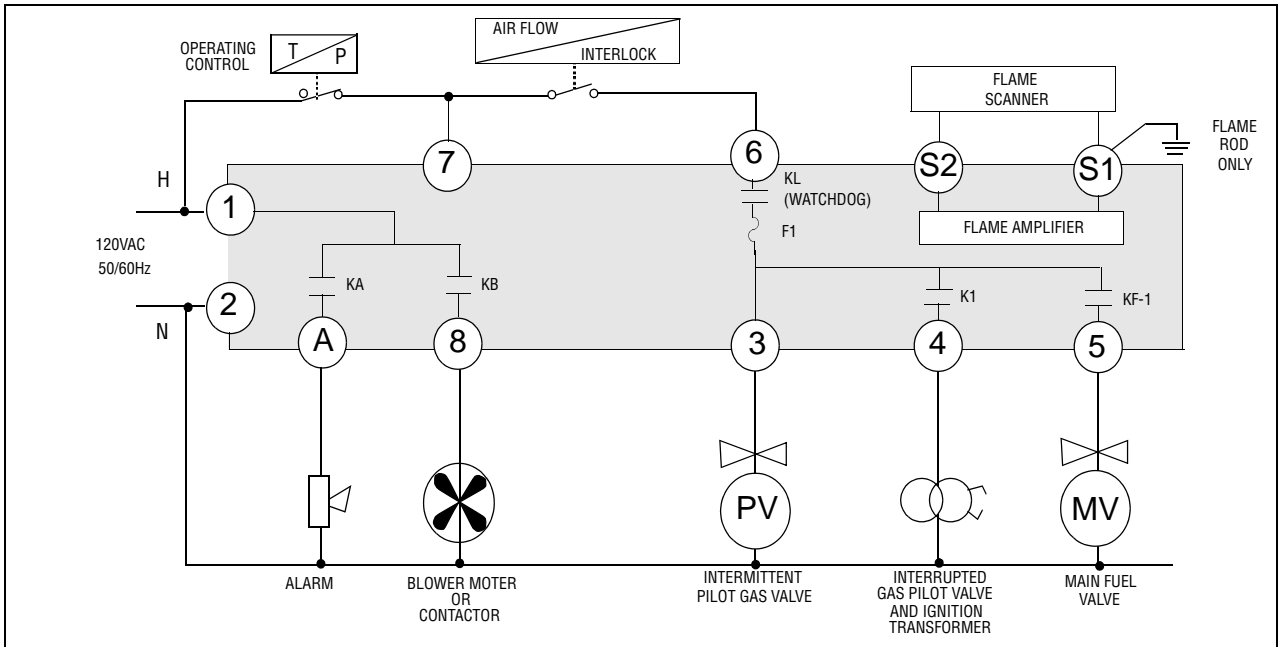
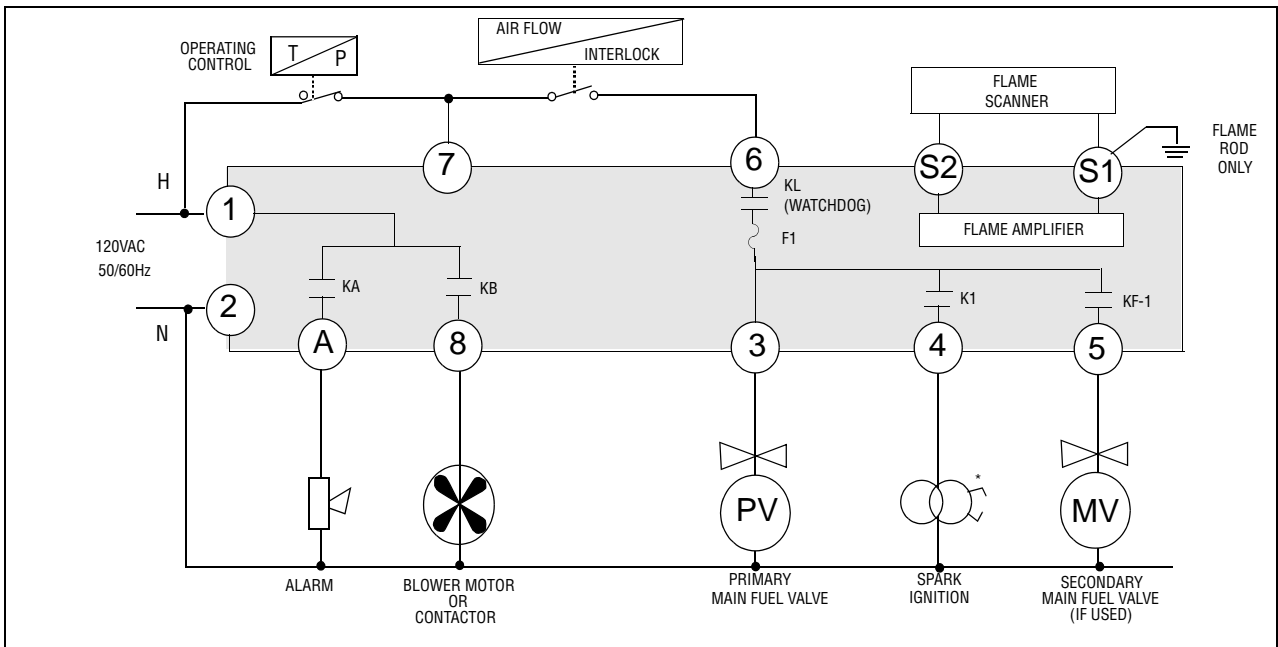
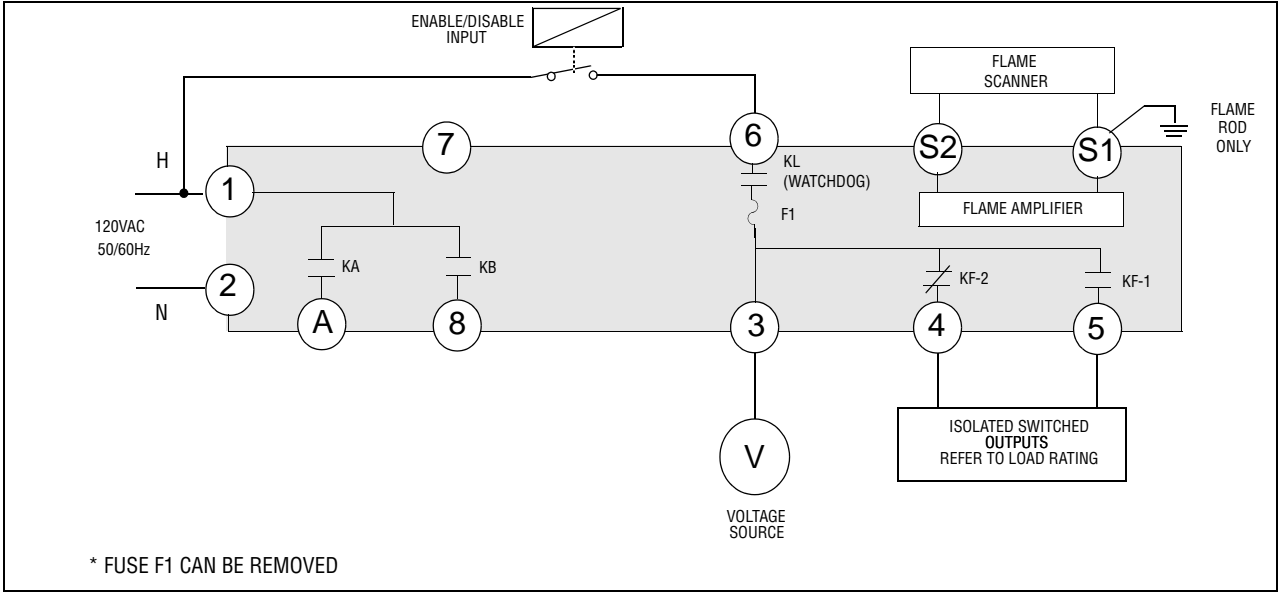

FIGURE 10. WIRING ARRANGEMENT FOR DIRECT SPARK IGNITED BURNERS AND INTERRUPTED IGNITION USING MEP500 SERIES PROGRAMMERS



*For intermittent ignition, connect to terminal 3

FIGURE 11. WIRING ARRANGEMENT FOR FLAME SWITCHES USING MEP100 PROGRAMMERS



NOTE: Air Flow LED will blink while flame is detected and KF relay is energized.

FIGURE 12. WIRING ARRANGEMENT FOR PILOT IGNITED BURNERS USING MEP300, MEP400 AND MEP600 SERIES PROGRAMMERS.

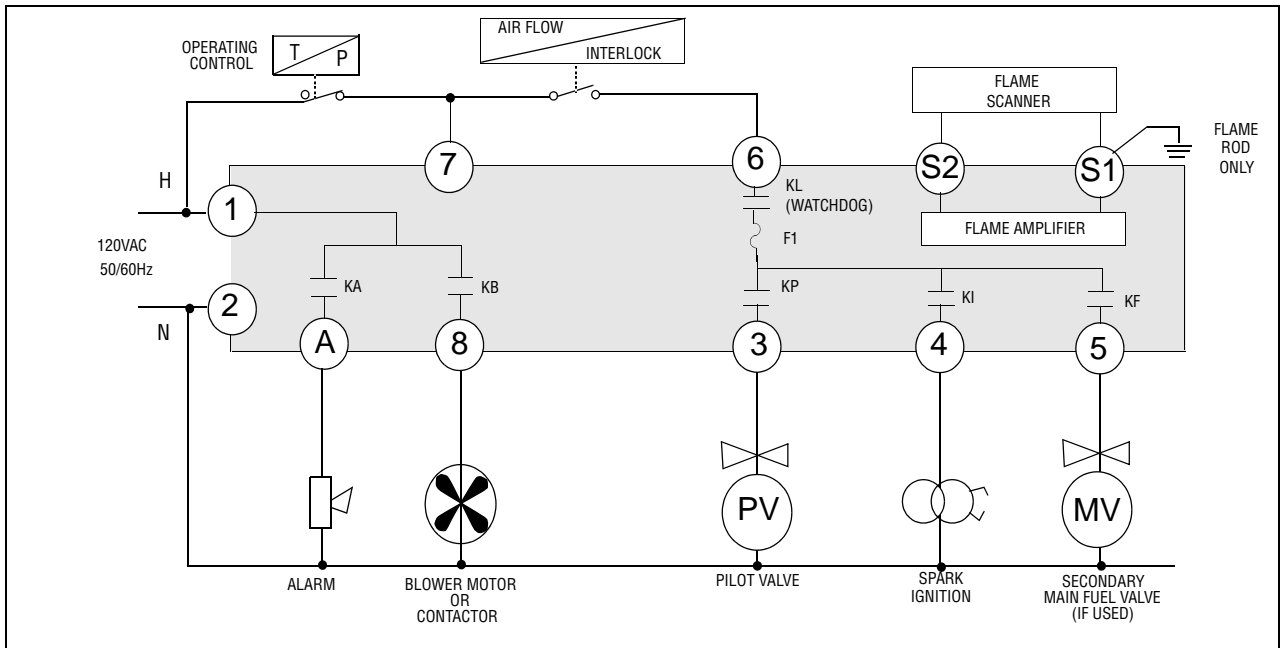
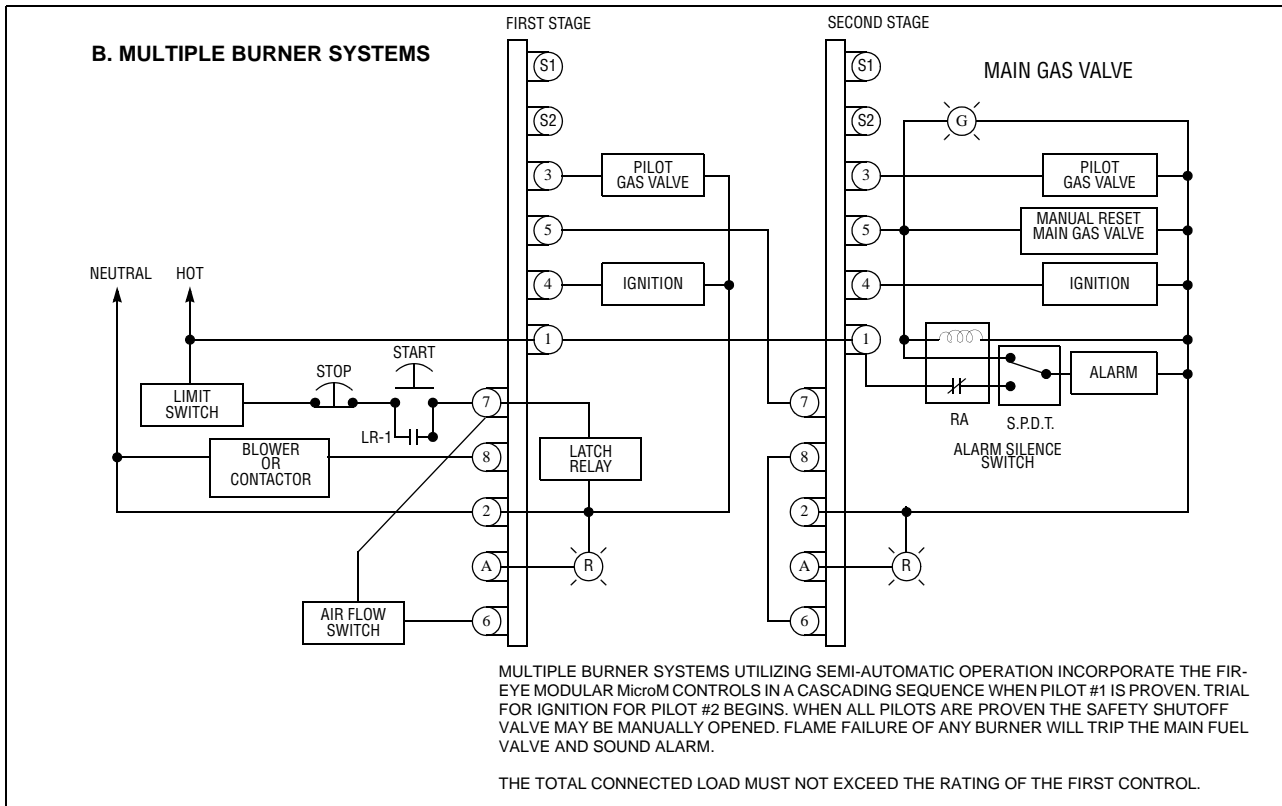
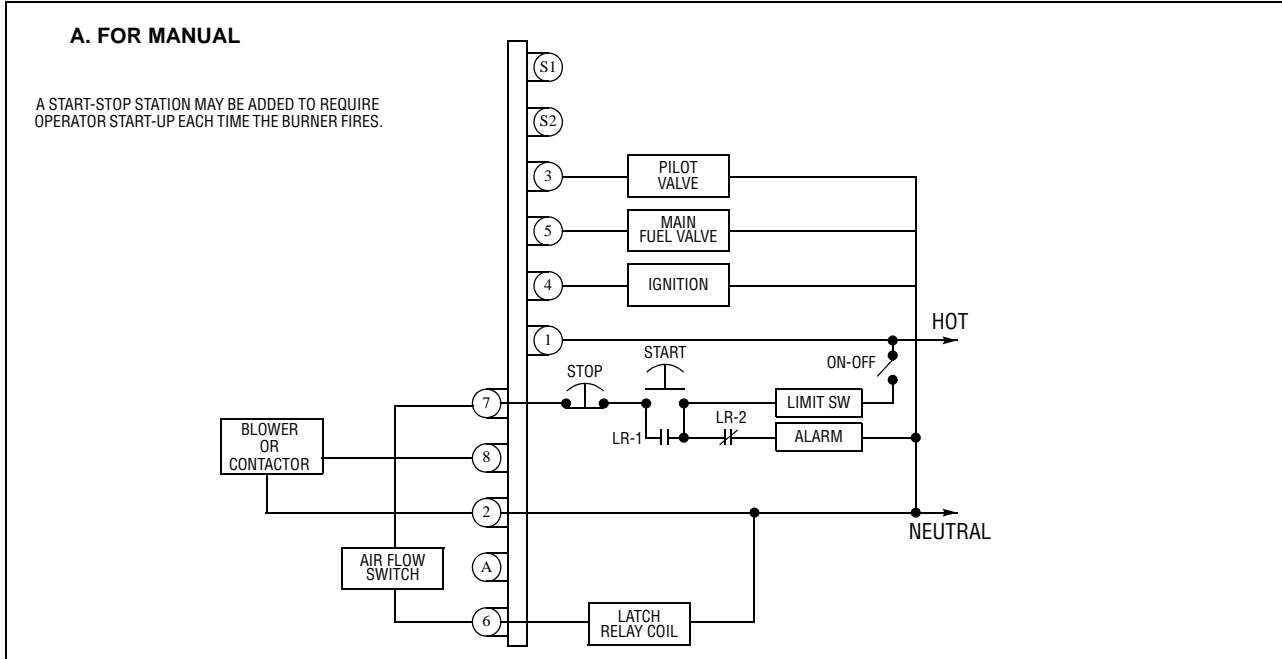
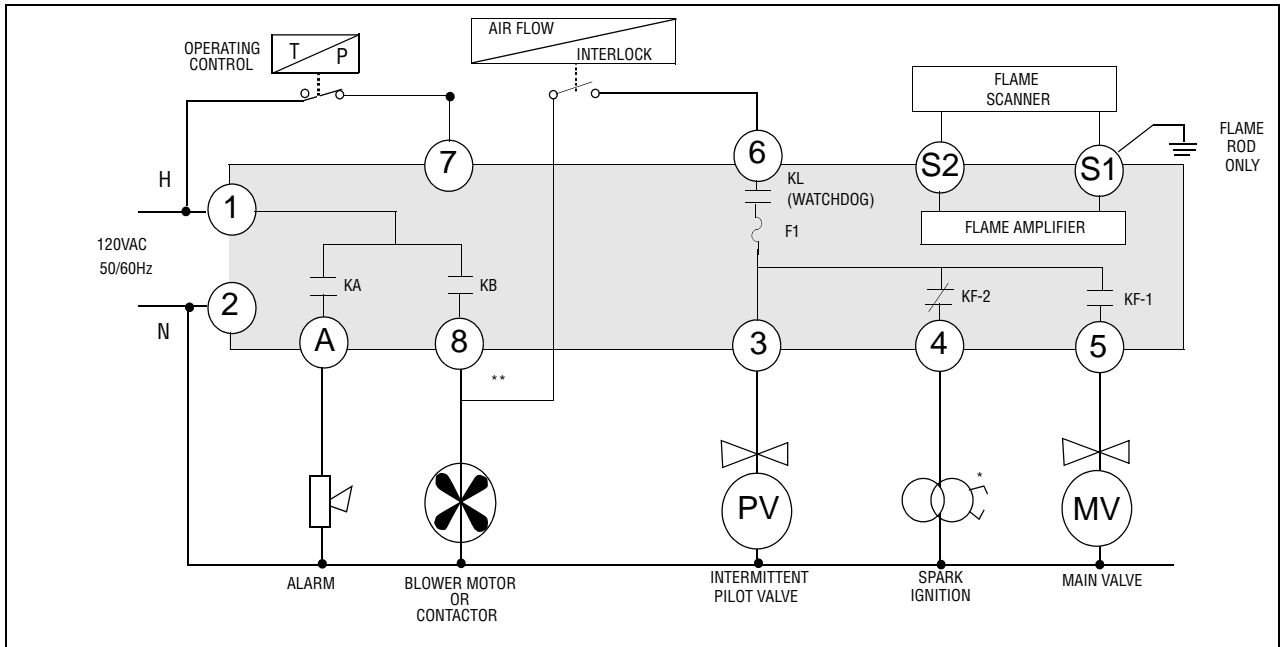

FIGURE 13. ALTERNATE WIRING ARRANGMENT FOR MEP CONTROLS



IMPORTANT: Use moisture resistant wire rated 90°C minimum.

FIGURE 14. BACKWARD COMPATIBLE WIRING USING MEP100 AND MEP200 SERIES PROGRAMMERS (PILOT IGNITED BURNERS).



- * For intermittent ignition, connect to terminal 3
- ** Combined current from Terminal 8 must not exceed 9.8 Amps

FIGURE 15. BACKWARD COMPATIBLE WIRING USING MEP500 SERIES PROGRAMMERS (PILOT IGNITED BURNERS)

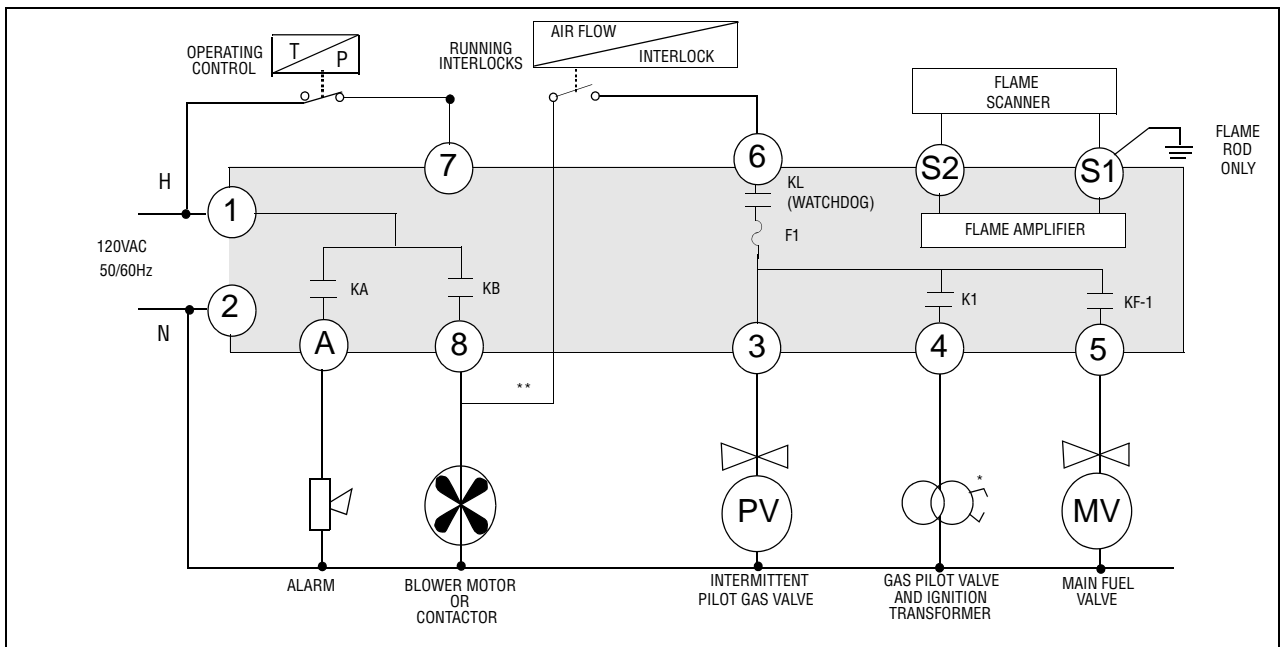

- * For intermittent ignition, connect to terminal 3
- ** Combined current from Terminal 8 must not exceed 9.8 Amps

SUGGESTED GROUNDING RULES

The MicroM system, being microprocessor based, requires a ground system that provides a zero-voltage reference. The voltage measured from L2 to all other terminals except L1 should be 0 volts.

1. The most effective ground is to run the ground wire in the same raceway as the hot and neutral from the main distribution service panel (not intermediate sub-panels) to the burner control panel and insure that this ground wire is well bonded to the control panel.
2. The wiring base of the MicroM must have earth ground providing a connection between the sub-base and the control panel or the burner.
3. The earth ground wire must be capable of conducting the current to blow the 20A fuse in event of an internal short circuit. A number 14 AWG copper conductor is adequate, wide straps or brackets are preferred rather than lead wires.
4. The ground path needs to be low impedance (less than 1 ohm) to the equipment frame which in turn needs a low impedance to earth ground. For a ground path to be low impedance at RF frequencies, the connection must be made with minimum length conductors having maximum surface areas.
5. All connections should be free of nonconductive coatings and protected against rust.
6. Utilizing conduit as a means of providing a ground must be avoided.
7. Installing ground rods at the burner control panel defeats the purpose of a single point ground as described above and could also present a safety hazard.

INSTALLATION

Do not run high voltage ignition transformer wires in the same conduit with flame detection wiring.

Do not run scanner wires in a conduit with line voltage circuits.

Ensure the frame of the ignition transformer is securely connected to control panel frame or preferably the burner frame.

The MicroM chassis (MEC120) contains a transient suppressing device connected internally across hot and neutral and then to the internal bracket. For this to be effective the chassis must be screwed securely into the wiring subbase.

REMOTE DISPLAY

When the ED510 is to be remotely mounted on the front of the control panel, the ED580 cable must contain a ferrite core, currently supplied by Fireye with the cable. The cable end with the ferrite core must be mounted at the control end. High frequency currents flow more to the surface of the conductor. The 60 Hz ground system, properly designed, has sufficient low-impedance at 60 Hz to maintain all metal surfaces at the same ground reference. But, this same system is unable to provide this at higher frequencies, because of the increased impedance caused by the 'skin effect'. The purpose of the ferrite core is to provide a low-impedance at these higher frequencies and absorb this unwanted energy.

Care must be taken not to route the ED580 cable in close proximity to any starter motor contactors located in the control panel or across any high voltage ignition wires. Refer to Fireye bulletin E-8002 for proper installation.

COMMUNICATIONS

When interfacing Fireye controls to a communication system, be it an E500, PLC or other microprocessor based device, ferrite cores should also be utilized. Proper twisted shielded pair cable must be utilized. In a multi-drop system, the shields should be tied together within a cabinet and not to any ground point. The shield at the source end of the cable of the multi-drop connection can then be terminated to ground. Source end is defined as the originating end of the communication system

Care must be taken not to route communication cables in close proximity to any starter motor contactors located in the control panel or across any high voltage ignition wires. Refer to Fireye bulletin E-8002 for proper installation.

SCANNERS

The armored cable supplied with the Ultra-Violet and Infrared scanners should be connected to equipment by means of a good mechanical connection such as a conduit fitting. It may be necessary to utilize heat insulator (P/N 35-69) to isolate the sensing end of the scanner from boiler ground. Care must be taken not to route the scanner cable across the high voltage ignition cable. The high energy ignition cable should be checked periodically for cracking, connections and aging.

In applications using flame rod units and the MERT amplifier, it may be beneficial to route a separate return wire from the S1 terminal to the flame rod assembly. This will minimize the effects of transient currents flowing into the MicroM.

In all cases, scanner wires should be routed in separate conduit and not joined with any high voltage AC or ignition cables.

MAINTENANCE

Periodically, the spark electrode should be inspected for proper gapping and cracked ceramics. At ignition time, the high energy from the ignition transformer will attempt to conduct to the point of least resistance and with an improper spark gap, where the conduction takes place will no longer be controlled.

The VA rating of the control transformer must be sized to handle the inrush currents of the pilot solenoid and ignition transformer at PTFI and then the inrush currents of the main fuel valve assembly at MTFI time.

Inspect neatness of wiring in junction boxes and cabinets. It is best to have connections short and direct and also not having wires bunched up and tied off. Also, connections should be periodically inspected for tightness and corrosion.

INSTALLATION - UV SCANNERS

Where possible, obtain the burner manufacturer's instructions for mounting the scanner. This information is available for most standard burners. The scanner mounting should comply with the following general instructions:

1. Position the UV1, UV2 scanner within 30 inches of the flame to be monitored; the 45UV5 within 72 inches, closer if possible.
2. Select a scanner location that will remain within the ambient temperature limits of the UV Scanner. If cooling is required, use an insulating coupling (Fireye P/N 35-69 for UV1, UV2 Scanners, P/N 35-127-1 for 45UV5) to reduce conducted heat.
3. The UV1, UV2, 45UV5 Scanners are designed to seal off the sight pipe up to 1 PSI pressure. Higher furnace pressures should be sealed off. To seal off positive furnace pressure up to 100 PSI for UV1, UV2 Scanners, install a quartz window coupling (#60-1257) For 45UV5 Scanners, use #60-1199 coupling. Add cooling air to reduce the scanner sight pipe temperature.
4. Install the scanner on a standard NPT pipe (UV1: 1/2", UV2: 3/8", 45UV5: 1") whose position is rigidly fixed. If the scanner mounting pipe sights through the refractory, do not extend it more

than halfway through. Swivel flanges are available if desired (#60-302 for UV1, UV2 Scanners, #60-1664-3 for 45UV5). The sight pipe must permit an unobstructed view of the pilot and/or main flame, and both pilot and main flames must completely cover the scanner field of view.

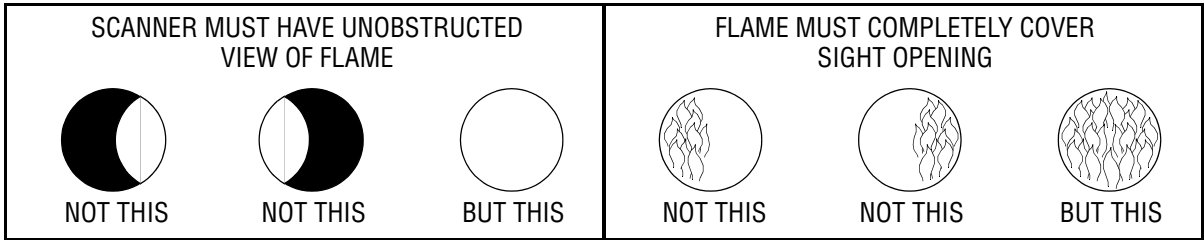

5. Smoke or unburned combustion gases absorb ultraviolet energy. On installations with negative pressure combustion chambers, a small hole drilled in the UV1, UV2 sight pipe will assist in keeping the pipe clean and free from smoke. For positive pressure furnaces, provide clean air to pressurize the sight pipe, if necessary.
6. Two UV1 or UV2 Scanners may be installed on the burner if it is necessary to view two areas to obtain reliable detection of the flame. They should be wired in parallel. Only one repetitive self-checking 45UV5 Scanner may be installed on a burner.

To increase scanner sensitivity with UV1, UV2 Scanners, a quartz lens permits location of the scanner at twice the normal distance. Use 1/2" x 1 1/2" pipe nipple between UV1 Scanner and the coupling. Use 3/8" pipe nipple and a 1/2" x 3/8" bushing on UV2 installations.

7. Request the assistance of any Fireye field office for recommendations of a proper scanner installation on a non-standard application.

TYPICAL SCANNER INSTALLATIONS

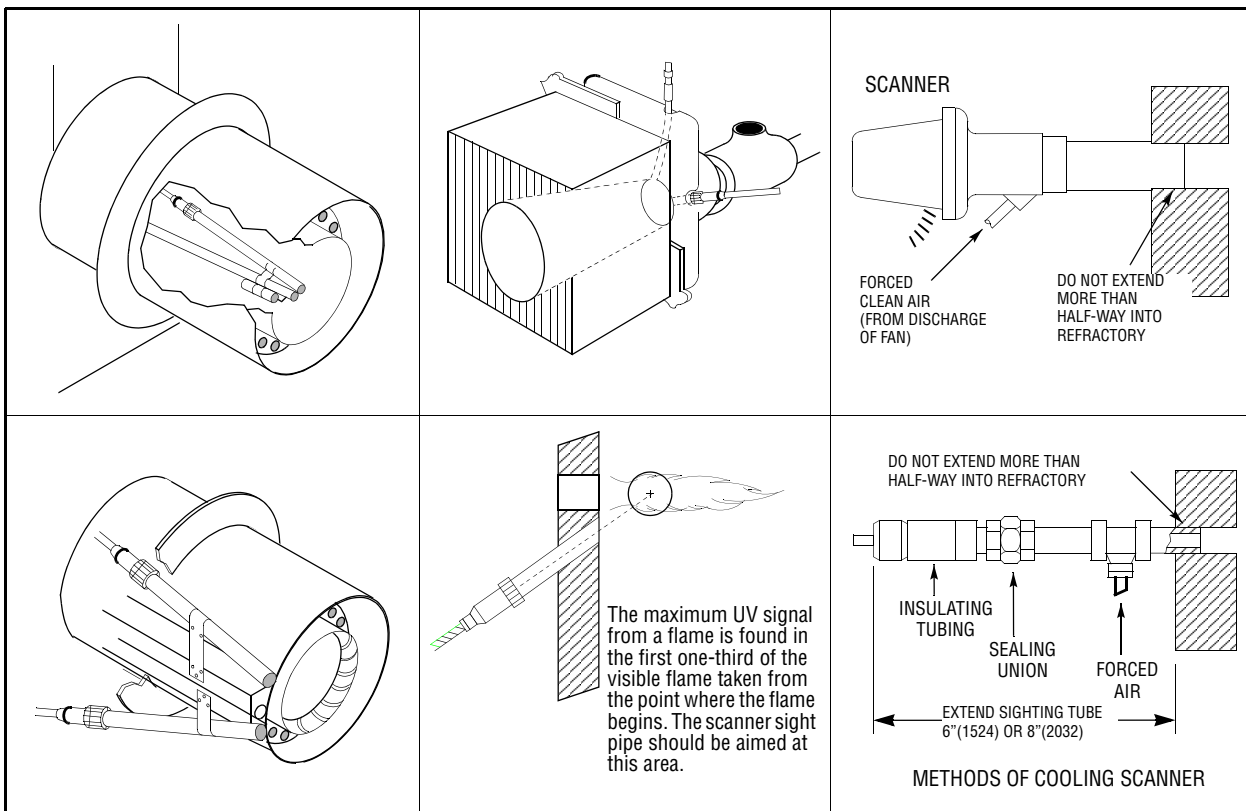

OPERATION — 45UV5 SELF-CHECKING UV SCANNER

Self-checking ultraviolet scanners should be used in applications where burner firing operation is continuous or where the burner is on for long periods of time without recycling. In addition, ultraviolet self-checking systems are mandatory in some locations.

The operation of this type of system consists of maintaining the flame scanning capability at all times while also proving that the ultraviolet tube is firing properly. This is done periodically by mechanically closing off the sight of the UV tube and checking to make sure that the flame signal goes away. A shutter assembly in the 45UV5 scanner performs this function. The diagram below explains the process further.

If the shutter assembly in the scanner fails, the tube is faulty, or there is insufficient power to the scanner, the MicroM will LOCKOUT and display the following message LOCKOUT CHECK SCANNER. The ultraviolet tube is replaceable (P/N 4-314-1).

A lockout will result if a minimum signal is detected for three consecutive shutter closed periods.

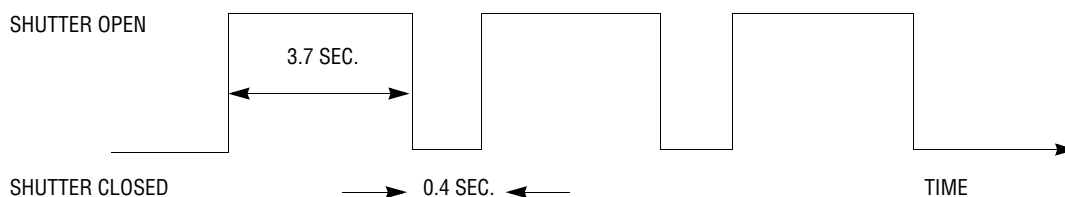

WIRING - UV SCANNERS

To connect the scanner to the control, the UV1 Scanner is supplied with 36" or 72" of flexible cable. The 45UV5 is supplied with four 72 inch lead wires. Install them in a suitable length of flexible armor cable and connect it to the control. A conduit connector is supplied with the scanner. Connect black wires (shutter) to terminals L1, L2; red wires (UV tube) to terminals S1, S2.

If it is necessary to extend the scanner wiring, the following instructions apply:

Scanner wires should be installed in a separate conduit. The wires from several scanners may be installed in a common conduit.

1. Selection of Wire
 - a. Wiring: For extended scanner wiring up to 500 feet, and for shorter lengths to reduce signal loss, use a shielded wire (Belden 8254-RG62 coaxial cable, or equal) for **each scanner wire** of UV1, UV2 and **each red wire** of the 45UV5. **The ends of the shielding must be taped and not grounded.**
 - b. Asbestos insulated wire should be avoided.
 - c. Multiconductor cable is not recommended without prior factory approval.
2. High voltage ignition wiring should not be installed in the same conduit with flame detector wires.

INSTALLATION—INFRARED SCANNER TYPE 48PT2

Where possible, obtain the burner manufacturer's instructions for mounting the scanner, otherwise proceed as follows:

A single scanner is used to detect both pilot and main flames. The sight pipe on which the scanner mounts must be aimed so that the scanner sights a point at the intersection of main and pilot flames.

Proper scanner positioning must assure the following:

1. Reliable pilot flame signal.
2. Reliable main flame signal.
3. A pilot flame too short or in the wrong position to ignite the main flame reliably, must not be detected.
4. Scanner must have an unobstructed view of flame being monitored.
5. Flame being monitored must completely cover the scanner field of view.
6. To avoid nuisance shutdowns, it is important to avoid sighting hot refractory and to keep scanner temperature low (below 125° F) (50°C).

When the proper position has been established, drill a hole through the furnace wall and install a 4" to 8" length of threaded 1/2" black iron pipe on which to mount the 48PT2 scanner.

7. When satisfactory sighting position has been confirmed by operating tests, the sight tube should be firmly welded in place.

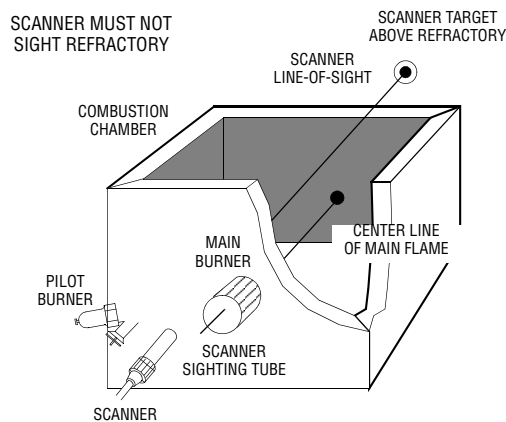

Wiring

Attach the cable supplied with the scanner to a junction box. Splice the cable wires to a pair of wires not smaller than #18. Install the complete run in a separate conduit to the control. **Continuous conduit bonding between scanner and the control is mandatory!** Scanner may be located up to 100 feet from control. Do not pass scanner wiring through any junction box containing other wires. Do not run other wires through scanner conduit. Asbestos insulated wire should be avoided.

Keeping the Scanner Cool

The Infrared Scanner (Temperature Limit 125° F) should never get too hot to grasp comfortably in the hand. Keep the scanner cool by one or more of the following methods.

1. Use 6" to 8" length of pipe between scanner and hot furnace front plate.
2. Use insulating tube (P/N 35-69) on the end of the iron pipe.
3. Force air into sighting tube. Use Fireeye Sealing Union (P/N 60-801).
4. Make sure sighting tube does not extend more than halfway into refractory wall.

INSTALLATION - 69NDI FLAME ROD

The 69NDI flame rod proves a gas pilot flame and/or main gas flame. It is a spark plug type unit consisting of 1/2" NPT mount, a KANTHAL flame rod, a glazed porcelain insulating rod holder and a spark plug connector for making electrical connections. The 69ND1 is available in 12", 18" or 24" lengths.

The flame rod may be located to monitor only the gas pilot flame or both the gas pilot and main gas flames. It is mounted on a 1/2" NPT coupling.

The following instructions should be observed:

1. Keep flame rod as short as possible.
2. Keep flame rod at least 1/2" from any refractory.
3. Flame rod should enter the pilot flame from the side so as to safely prove an adequate pilot flame under all draft conditions.
4. If the flame is nonluminous (air and gas mixed before burning), the electrode tip should extend at least 1/2" into the flame, but not more than halfway through.

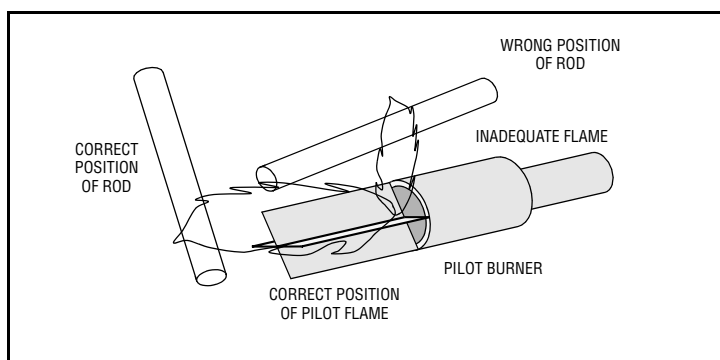

5. If the flame is partly luminous, the electrode tip should extend only to the edge of the flame. It is not necessary to maintain absolutely uninterrupted contact with the flame.
6. It is preferable to angle the rod downward to minimize the effect of sagging and to prevent it from coming in contact with any object.
7. An adequate grounding surface for the flame must be provided. The grounding surface in actual contact with the flame must be at least four times greater than the area of the portion of the flame rod in contact with the flame. It is essential to adjust the flame rod and ground area ratio to provide a maximum signal reading.

NOTE: Interference from the ignition spark can alter the true signal reading by adding to, or subtracting from it. This trend sometimes may be reversed by interchanging the primary wires (line voltage) to the ignition transformer. This interference can also be reduced by the addition of grounded shielding between the flame rod and ignition spark.

8. Proven types of flame grounding adapters, as shown below, may be used to provide adequate grounding surface. High temperature stainless steel should be used to minimized the effect of metal oxidation. This assembly may be welded directly over the pilot or main burner nozzle.

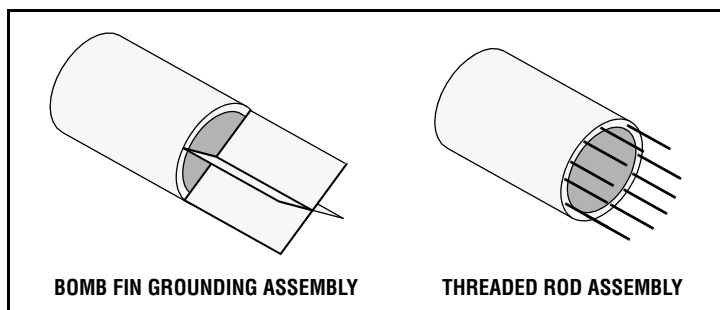

MAINTENANCE

Type 48PT2 Infrared and Type UV1, UV2 and 45UV5 Ultraviolet Scanners

The viewing area of the scanner must be kept clean. Even a small amount of contamination will reduce the flame signal reaching the detector by a measurable amount. Wipe the viewing area routinely using a soft cloth dampened with concentrated detergent.

- Type 48PT2 Scanners include a replaceable #4-263-1 Firetron cell.
- Type 45UV5 Scanners include a replaceable #4-314-1 UV tube.

Type 69ND1 Flame Rod

The flame rod and its insulator should be kept clean by washing routinely with soap and water. Rods should be routinely replaced as they oxidize.

Flame Signal Strength

Routine observation of the flame signal strength will forewarn any deterioration in the capability of the flame detector or its application.

Contacts

There are no accessible contacts in the MicroM. Where contacts are used, their design assures long trouble-free life when the load circuits are maintained within the published load ratings.

Humidity

In areas of high humidity, the control chassis should be removed and placed in a dry atmosphere when the system is expected to be out of service for an extended period.

Periodic Safety Check

It is recommended that a procedure be established to test the complete flame safeguard system at least once a month. This test should verify the proper operation of all limit switches and safety interlocks as well as flame failure protection and fuel safety shutoff valve tightness.

Rotation

It is recommended that control and scanner units purchased as spares be installed periodically to ensure proper operation.

FIGURE 16. Mounting 45UV5 Scanner

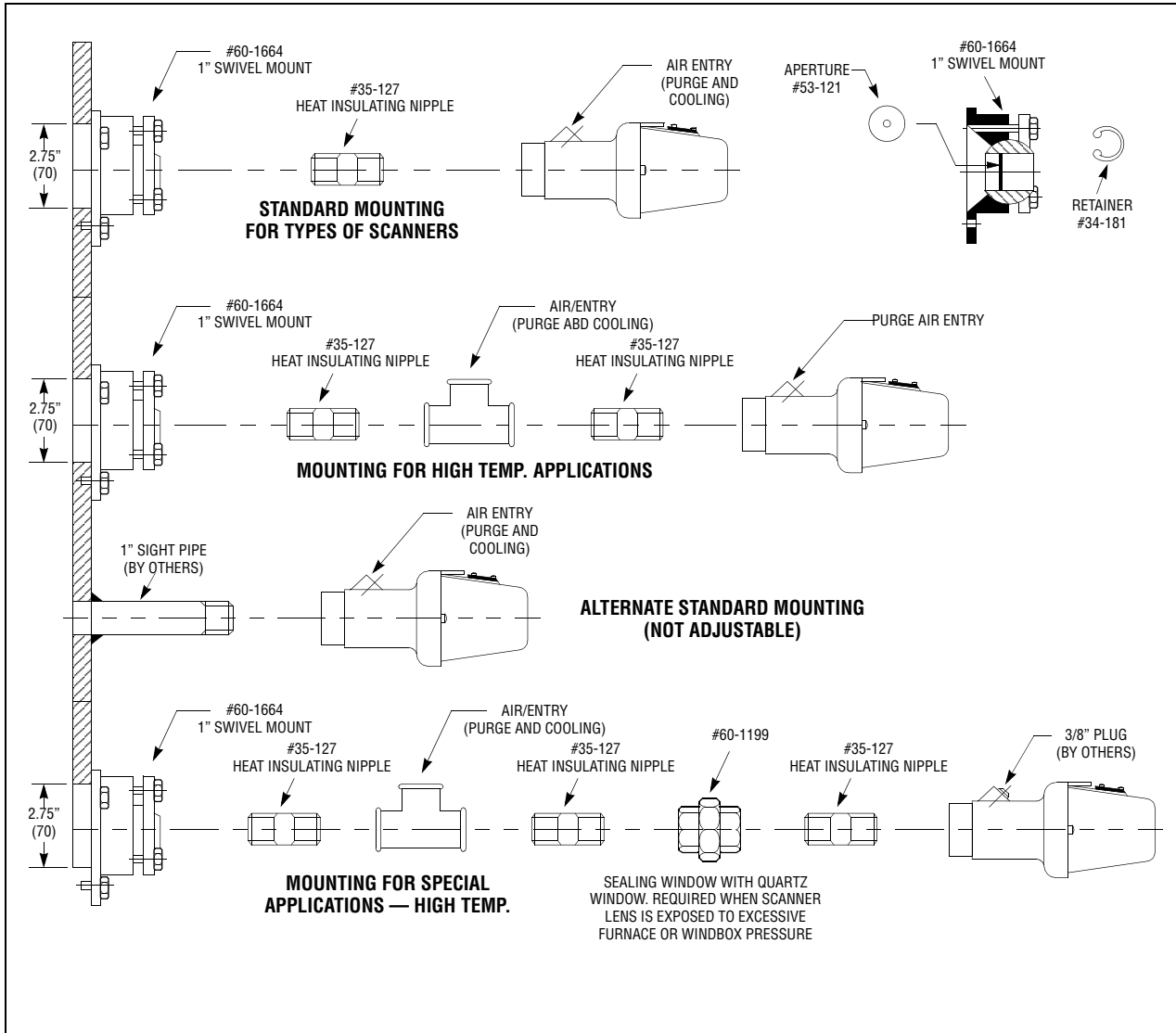

FIGURE 17. UV8A Scanner

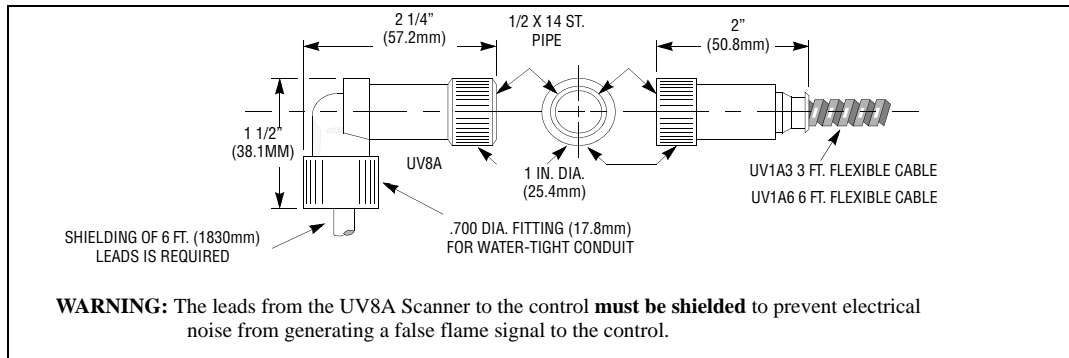
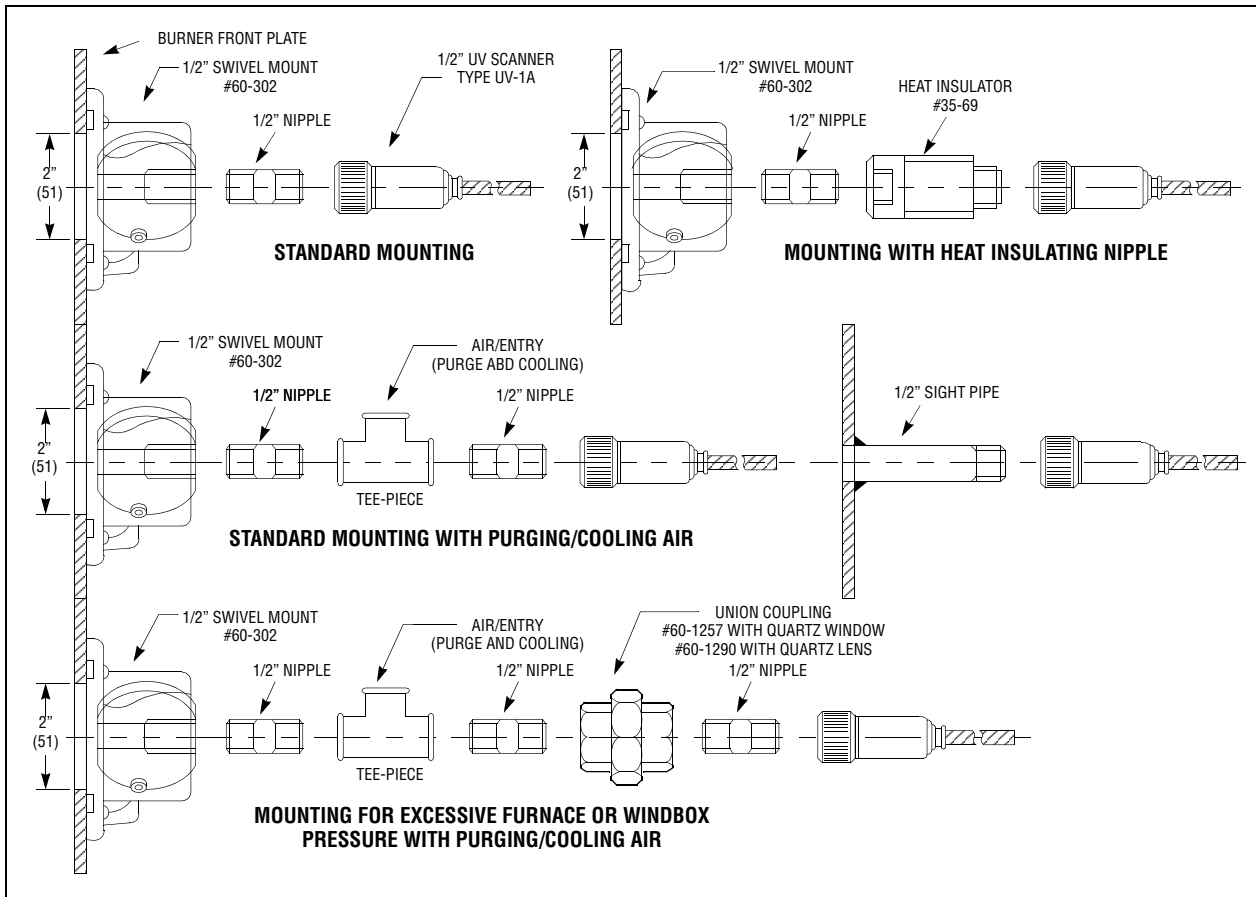

FIGURE 18. Mounting UV1A/UV1B Scanners





M-SERIES TO M-SERIES II TO MICROM CROSS REFERENCE LISTING

M-SERIES Part Number	M-SERIES II REPLACEMENT MODULES				MicroM REPLACEMENT MODULES			
	Chassis	Amplifier	Programmer	Programmer Dipswitch #8	Chassis	Amplifier	Programmer	Programmer Dipswitch #6
UVM1D	MC120	MAUV1T	MP100	N/A	MEC120	MEUV1	MEP100	N/A
UVM1F	MC120	MAUVI	MP100	N/A	MEC120	MEUV4	MEP100	N/A
TFM1D	MC120	MART1T	MP100	See Note #1	MEC120	MERT1	MEP100	N/A
TFM1F	MC120	MART1	MP100	See Note #1	MEC120	MERT4	MEP100	N/A
UVM2	MC120	MAUV1	MP230	OFF	MEC120	MEUV4	MEP230	C
TFM2	MC120	MART1	MP230	OFF	MEC120	MERT4	MEP230	C
UVM3	MC120	MAUV1	MP230	ON	MEC120	MEUV4	MEP230	O
TFM3	MC120	MART1	MP230	ON	MEC120	MERT4	MEP230	O
UVM3H	MC120	MAUV1	MP230H	ON	MEC120	MEUV4	MEP230H	O
TFM3H	MC120	MART1	MP230H	ON	MEC120	MERT4	MEP230H	O
UVM5	MC120	MAUV1	MP560	ON	MEC120	MEUV4	MEP560	O
UVM6	MC120	MAUV1	MP560	See Note #2	MEC120	MEUV4	MEP560	C
- N/A — Not Applicable - Programmer Dipswitches apply to MP230H, and MP560 only. - Dipswitch #8 sets Recycle / Non-Recycle Operation. - MP560 Programmer Module has "Check-Run" Switch. - Note #1: For Standing Pilot, clip out red jumper on MP100. - Note #2: Dipswitch #8 ON when red jumper of UVM6 is clipped.					- N/A — Not Applicable - Programmer Dipswitches apply to MEP200, and MEP500 Series Programmers - Dipswitch #6 sets Recycle / Non-Recycle Operation. (O = Non-Recycle, C = Recycle) - MEP500 Series Programmer Module has "Check-Run" Switch			

PURGE	PTFI	M-Series II PROGRAMMER DIPSWITCH SETTINGS							MicroM PROGRAMMER DIPSWITCH SETTINGS			
TIME	TIME	#1	#2	#3	#4	#5	#6	#7	#1	#2	#4	#6
7	5	ON	OFF	OFF	OFF	OFF	ON	OFF	C	C	C	C
7	5	OFF	ON	OFF	OFF	OFF	ON	OFF	C	C	C	C
30	5	OFF	OFF	ON	OFF	OFF	ON	OFF	O	C	C	C
7	10	OFF	ON	OFF	OFF	OFF	OFF	ON	C	C	O	O
90	5	OFF	OFF	ON	ON	OFF	ON	OFF	O	O	C	C
30	10	OFF	OFF	ON	OFF	OFF	OFF	ON	O	C	O	O
60	10	OFF	OFF	OFF	ON	OFF	OFF	ON	C	O	O	O
90	10	OFF	OFF	ON	ON	OFF	OFF	ON	O	O	O	O
- Dipswitches #1 through #5 set Purge Timing - Dipswitches #6 and #7 set TFI Timing									- Dipswitches #1 through #2 set Purge Timing - Dipswitch #4 sets TFI Timing - Dipswitch #6 set Recycle/Non-Recycle			

M-SERIES TIMING CARDS	PURGE TIME	PTFI TIME
MT55	5	5
MT74	7	4
MT304	30	4
MT710	7	10
MT904	90	4
MT3010	30	10
MT6010	60	10
MT9010	90	10





NOTICE

When Fireye products are combined with equipment manufactured by others and/or integrated into systems designed or manufactured by others, the Fireye warranty, as stated in its General Terms and Conditions of Sale, pertains only to the Fireye products and not to any other equipment or to the combined system or its overall performance.

WARRANTIES

FIREYE guarantees for *one year from the date of installation or 18 months from date of manufacture* of its products to replace, or, at its option, to repair any product or part thereof (except lamps, electronic tubes and photocells) which is found defective in material or workmanship or which otherwise fails to conform to the description of the product on the face of its sales order. **THE FOREGOING IS IN LIEU OF ALL OTHER WARRANTIES AND FIREYE MAKES NO WARRANTY OF MERCHANTABILITY OR ANY OTHER WARRANTY, EXPRESS OR IMPLIED.** Except as specifically stated in these general terms and conditions of sale, remedies with respect to any product or part number manufactured or sold by Fireye shall be limited exclusively to the right to replacement or repair as above provided. In no event shall Fireye be liable for consequential or special damages of any nature that may arise in connection with such product or part.



FIREYE
3 Manchester Road
Derry, New Hampshire 03038 USA
www.Fireye.com

MC-5000
DECEMBER 19, 2005
Supersedes July 7, 2005

