



Installation, Operation, and Maintenance Manual

CONQUEST® Water Heater with EOS (Electronic Operating System)

Models with B&G Pump:

CQT (400, 500, 600, 700, 800, 900, 1000, 1100, 1200) (O)

Outdoor Model Numbers (O)

Read this Manual BEFORE using this equipment. Failure to read and follow all safety and use information can result in death, serious personal injury, property damage, or damage to the equipment.

Keep this Manual for future reference.

Important: This manual contains information required for installation, operation, and maintenance of this equipment. Read and follow the information in this manual and all other provided instructions, labels, and markings before installing, operating, or servicing this unit. Installation and service must be performed by a qualified service installer, service agency, or the gas supplier.

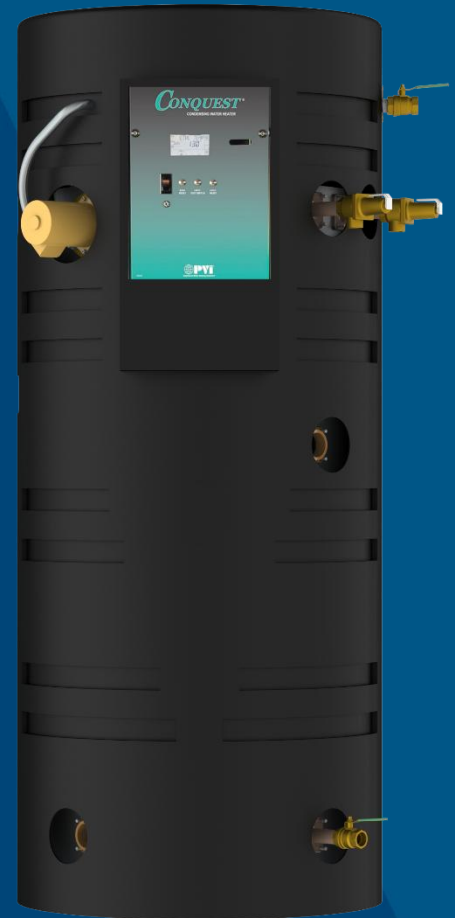

Disclaimer

The information contained in this manual is subject to change without notice from Watts Heating and Hot Water Solutions LLC d/b/a PVI Industries, LLC. ("PVI"). PVI makes no warranty of any kind with respect to this material, including, but not limited to, implied warranties of merchantability and fitness for a particular application. Some states do not allow the exclusion or limitation of incidental or consequential damages, so the above limitation may not apply. PVI is not liable for errors appearing in this manual, not for incidental or consequential damages occurring in connection with the furnishing, performance, or use of these materials.



Manufacturing ASME Commercial Water Heaters Since 1961

PVI Industries, LLC • Fort Worth, TX
USA: T: (817) 335-9531 • Toll Free: (800) 784-8326 • PVI.com
Technical Support • (800) 433-5654 (Option 1) • Mon-Fri, 8 am – 5 pm CST
© 2024 PVI, a Watts Brand

TABLE OF CONTENTS

SECTION 1: SAFETY CONSIDERATIONS	4
SECTION 2: PRODUCT DESCRIPTION	7
2.1 Models 400 through 1200	7
2.2 Models 400 through 1200 (O) Outdoor Conquest	8
SECTION 3: Water HEATER INSTALLATION.....	9
3.1 Checking Equipment Before You Install	9
3.2 Codes	9
3.3 Electrical Requirements	9
3.4 Handling and Positioning	10
3.5 Clearances To Combustible Surfaces	11
3.6 Service Clearances	11
3.7 Other Code and Regulatory Clearances and Requirements	11
SECTION 4: GENERAL PIPING GUIDELINES	12
4.1 Inlet and Outlet Connections	12
4.2 Building Return Piping.....	12
4.3 Requirement for 180°F Delivered Water to a Dish Machine.....	15
4.4 Booster Heater Applications	16
SECTION 5: CONDENSATE DRAIN, TRAP & DISPOSAL	18
5.1 Condensate Neutralization System (Optional).....	19
SECTION 6: GAS SUPPLY AND PIPING.....	21
6.1 Gas Train and Controls Certification	21
6.2 Gas Control Trains	21
6.3 Inlet Pressure	21
6.4 Gas Piping Size.....	21
6.5 Appliance Isolation during Gas Supply Piping Pressure Test.....	22
6.6 Gas Connection	23
SECTION 7: COMBUSTION SUPPLY AIR.....	24
7.1 Equipment Located in Confined Spaces	24
7.2 Maximum Remote Combustion Air Inlet Length (Equivalent)	25
7.3 Remote Combustion Air Cap	26
7.4 Vertical or Horizontal Remote Air Duct Termination	26
7.5 Combining Remote Air Ducting.....	26
7.6 Optional Filter Box for Dusty or Dirty Combustion Air.....	27
SECTION 8: VENTING	28
8.1 Venting the CONQUEST:.....	28
8.2 Maximum Vent Length (Equivalent Length).....	30
8.3 Vertical or Horizontal Vent Termination:	31
8.4 Combining Category IV Vents.....	32
8.5 Optional Concentric Vent for Combustion Air and Exhausting Flue Products (Models 400 to 800).....	32
8.6 Polypropylene Venting and Low-Profile Terminations	34
8.7 Connecting to an Existing Vent System	34
SECTION 9: OPERATING AND SAFETY CONTROLS	35
9.1 Temperature and Pressure Relief Valve(s).....	35
9.2 Cathodic Protection	35
9.3 Electronic Low Water Cut-Off	35
9.4 Operating Temperature Control	36
9.5 High Water Temperature Limit.....	36
SECTION 10: ELECTRONIC OPERATING SYSTEM (EOS)	37
10.1 Touch Screen User Interface	37
10.2 Status Field Display	38
10.3 Operational Sequence Field Display.....	38

10.4 View Menu (Home Screen - Default Display)	39
10.5 Control System Menus	39
10.6 Changing the Vent Material Type (Advanced Level Access)	40
10.7 Changing The Operating Set Point (USER Level Access)	41
10.8 Setting The Real Time Clock (User & Installer Level Access)	41
10.9 Scheduled Setback (USER Level Access)	42
10.10 Using the Manual Override Menu (ADVanced Level Access)	44
10.11 Using Toolbox Menu	45
10.12 Basic Operational Reference Information	46
SECTION 11: Section 11: COMMUNICATIONS AND DIAGNOSTICS	47
11.1 Indicators	47
11.2 Alarm Messages – Diagnostic Codes (Flashes)	47
11.3 Replacing the Fuse	48
11.4 Self-Check/Control Failure	48
11.5 System Safety Checks	48
11.6 Flame Current Measurements	48
11.7 Non-Volatile Lockout/Manual Reset	49
11.8 ID Card	49
SECTION 12: NETWORK MENU	50
SECTION 13: REMOTE CONNECTIONS – TERMINAL STRIP	51
13.1 BMS/BAS Remote Connections for Analog and Binary Signals	51
13.2 Terminal Functions	51
SECTION 14: SEQUENCE OF OPERATION	52
SECTION 15: INITIAL STARTUP	55
15.1 Initial Startup Requirements	55
15.2 Tools and Instrumentation Required	55
15.3 Resources	55
15.4 On-Site Considerations	55
15.5 Pre-Startup Checklist	55
15.6 Startup Procedure	58
SECTION 16: POTENTIOMETER (Adjusting the Set-point)	62
SECTION 17: NSF COMPLIANCE	62
SECTION 18: FOOD SERVICE INSTALLATION GUIDELINES	63
SECTION 19: INSTRUCTIONS FOR OUTDOOR MODELS	64
19.1 Flue Venting Termination	64
19.2 Condensate Drain	64
19.3 Service and Control Adjustment Access	65
19.4 Air Filter Cleaning	65
19.5 Control Enclosure Outdoor Cover	65
SECTION 20: TROUBLESHOOTING PROCEDURE	66
20.1 LED Error Code Listing	68
SECTION 21: REPLACEMENT PARTS (Indoor models only)	69
21.1 Blower & Burner Assemblies (Models 400 – 1200)	69
21.2 Control Panel Components	73
21.3 Drain Valve – T & P Relief Valve – Integral Circulating Pump Assembly	74
21.4 Condensate Drain Trap & Optional Condensate Neutralizer	74
21.5 Component Wiring and Routing Details	75
SECTION 22: PERIODIC MAINTENANCE GENERAL	76
SECTION 23: RECOMMENDED MAINTENANCE SCHEDULE	79
SECTION 24: MASSACHUSETTS REQUIREMENTS	80

SECTION 1: SAFETY CONSIDERATIONS

IMPORTANT SAFETY NOTE

It takes only 5 seconds of skin contact with 140°F water to cause a second-degree burn! You must protect against high water temperatures at all lavatories, tubs, showers, and other points of hot water contact.

Accidental scalding from high water temperatures is a greater risk in some types of installations. Some examples are:

- Homes for the mentally handicapped
- Homes for the physically handicapped
- Hospitals and nursing homes
- Elder care facilities and rest homes
- Orphanages and childcare facilities
- Other installations - where the response to contact with hot water may be slower, or the danger of hot water contact is greater.

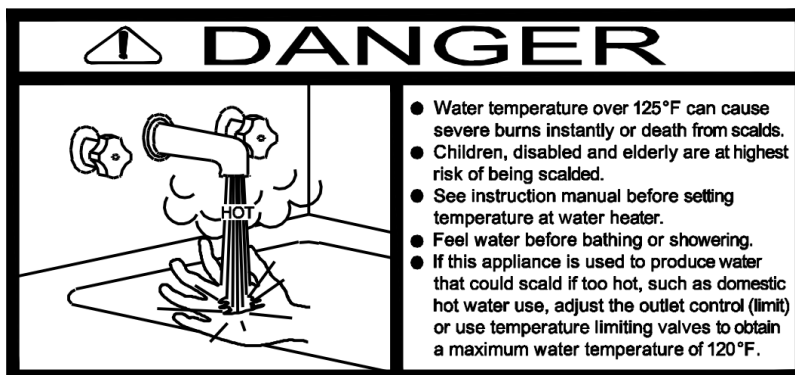

Thermostatically controlled mixing valves must be used in the design of the potable hot water system.

Potable hot water should be tempered to no more than 110°F when used for bathing or other personal uses at the point of use.

Good engineering practice mandates using thermostatically controlled mixing valves set at 120°F or less to keep the delivered water temperature below scalding temperatures within hot water systems.

WARNING: If the information in the supplied manual(s) is not followed exactly, a fire, explosion, or exposure to hazardous materials may result in property damage, personal injury, or death.

AVERTISSEMENT. Assurez-vous de bien suivre les instructions données dans cette notice pour réduire au minimum le risque d'incendie ou d'explosion ou pour éviter tout dommage matériel, toute blessure ou la mort.

FOR YOUR SAFETY

Do not store or use gasoline or other flammable vapors or liquids in the vicinity of this or any other appliance.

Ne pas entreposer ni utiliser d'essence ou ni d'autres vapeurs ou liquides inflammables à proximité de cet appareil ou de tout autre appareil.

WHAT TO DO IF YOU SMELL GAS

Do not try to light any appliance.

Do not touch any electric switch or use any phone in your building.

Immediately call your gas supplier from a location away from your building and the gas smell. Follow the gas supplier's instructions.

If you cannot reach your gas supplier, call the fire department.

QUE FAIRE SI VOUS SENTEZ UNE ODEUR DE GAZ:

Ne pas tenter d'allumer d'appareil.

Ne touches à aucun interrupteur; ne pas vous servir des téléphones se trouvant dans le bâtiment. Appelez immédiatement votre fournisseur de gaz depuis un voisin. Suivez les instructions de fournisseur. Si vous ne pouvez rejoindre le fournisseur, appelez le service de incendies.

A qualified installer, service agency, or gas supplier must perform installation and service.

L'installation et l'entreretien doivent être assurés ou un service d'entretien qualifié ou par le fournisseur de gaz.

This product contains or may come to contain materials identified as carcinogenic or possibly carcinogenic to humans. Read and follow the instructions before installing, servicing, or removing this product.

Clearance in accordance with the local installation codes and the requirements of the gas supplier. Dégagement conforme aux codes d'installation locaux et aux exigences du fournisseur de gaz.

Turn off the manual gas control valve if the appliance overheats or the gas supply fails to shut off.

En cas de surchauffe ou si l'alimentation en gaz ne s'arrête pas, fermez manuellement le robinet d'arrêt de l'admission de gaz.

WARNING: Installation and service must be performed by a qualified installer, service agency, or gas supplier, who must read and follow the supplied instructions before installing, servicing, or removing this appliance. Refer to the information contained in this manual. Improper installation, adjustment, alteration, service, or maintenance can cause property damage, personal injury, exposure to hazardous materials, or death.

WARNING: Do not use this appliance if any part is underwater. Immediately call a qualified service technician to inspect the unit and replace any part of the control system, all gas controls, and all other items affecting safe appliance operation that have been under water.

AVERTISSEMENT: N'utilisez pas cet appareil s'il a été plongé dans l'eau, même partiellement. Faites inspecter l'appareil par un technicien qualifié et remplacez toute partie du système de contrôle et toute commande qui ont été plongés dans l'eau.

WARNING: In an emergency, shut the main gas supply valve to the appliance from a location safely away from the emergency. Failure to follow these instructions can cause property damage, personal injury, exposure to hazardous materials, or death.

PRODUCT SAFETY INFORMATION
REFRACTORY CERAMIC FIBER PRODUCT WITH CRYSTALLINE SILICA

WARNING: This product contains or may come to contain crystalline silica, which the International Agency for Research has identified on Cancer (IARC) as carcinogenic to humans. This product also contains refractory ceramic fibers, which the IARC has identified as possibly carcinogenic to humans. Avoid breathing fiber particulates and dust.

RISKS:

- Air-borne fibrous insulation is a possible cancer hazard caused by inhalation.
- Airborne crystalline silica may cause silicosis (lung disease) by inhalation.
- May cause temporary irritation to eyes, skin, and respiratory tract.

PRECAUTIONARY MEASURES:

- Minimize airborne fibers with engineering controls.
- Use NIOSH/MSHA-approved respirators as required (see SDS).
- Wear long-sleeved, loose-fitting clothing, eye protection, and gloves.

FIRST AID MEASURES: (If any of the irritations listed persists, seek medical attention.)

- Eyes: Flush with water.
- Skin: Wash with soap and warm water.
- Ingestion: Do not induce vomiting. Get medical attention if gastrointestinal symptoms develop.
- Inhalation: Remove to fresh, clean air.

WARNING: If you are unfamiliar with the safe handling of refractory ceramic fiber products, or if you wish additional information prior to beginning any disassembly of the water heater or boiler that might expose refractory ceramic fiber materials, contact Unifrax Corporation, 2351 Whirlpool Street, Niagara Falls, NY 14305-2413, 1-800-322-2293.

IDENTIFICATION OF REFRACTORY CERAMIC FIBER MATERIALS (RCF):

The burner assembly utilizes RCF material. (The RCF materials are located within the product and are not generally exposed except during service, disassembly, or assembly.)

SECTION 2: PRODUCT DESCRIPTION

2.1 Models 400 through 1200

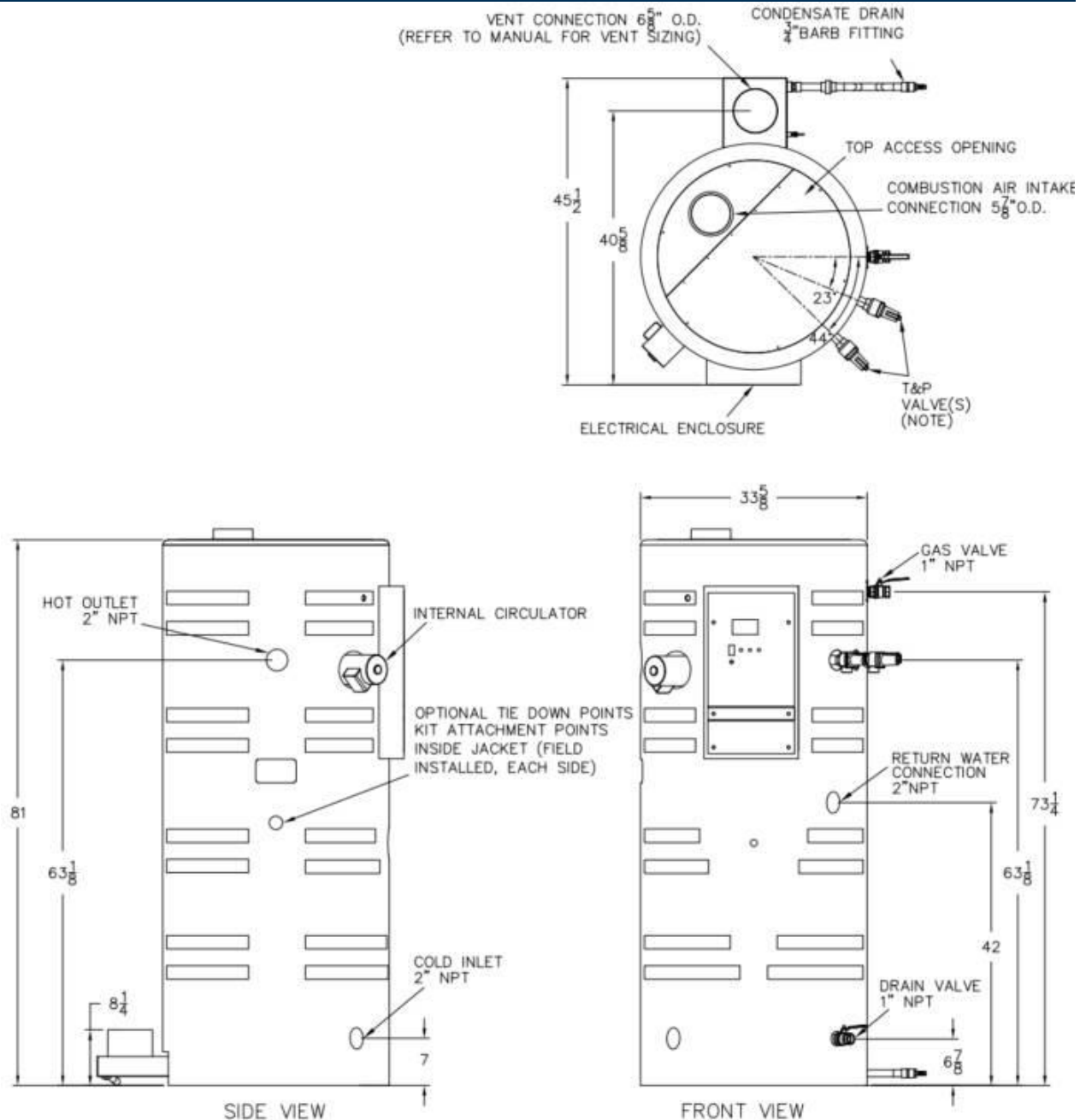

NOTES:

- THE STANDARD PRODUCT OFFERING WILL COME WITH ONE T&P VALVE. FOR THE CSA RELIEF VALVE OPTION STARTING AT 700,000 BTU, A SECOND RELIEF VALVE WILL BE PROVIDED AS SHOWN.

2.2 Models 400 through 1200 (O) Outdoor Conquest

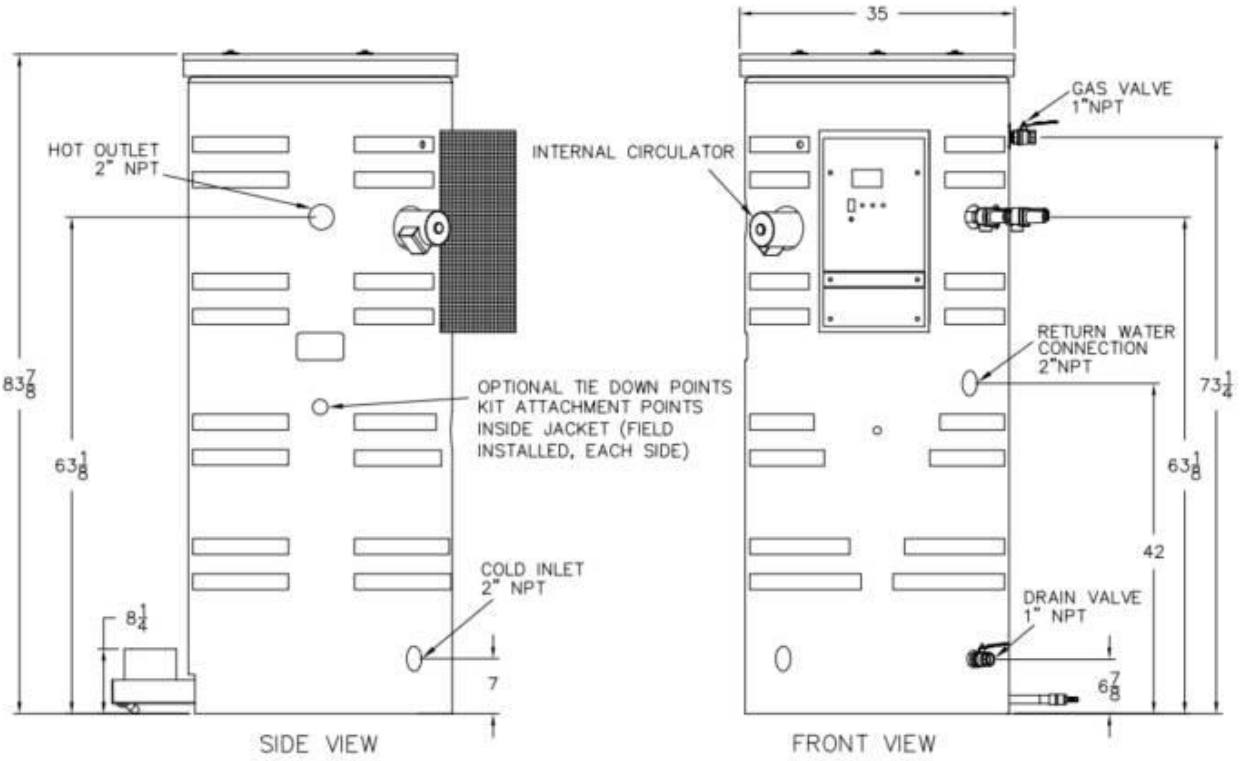
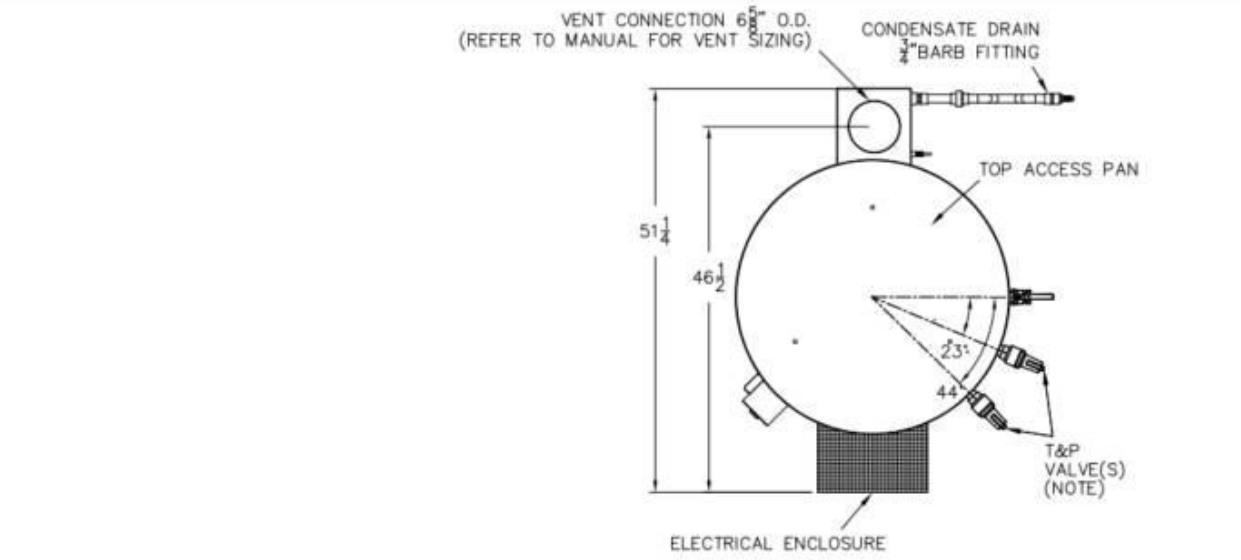

- NOTES:
- THE STANDARD PRODUCT OFFERING WILL COME WITH ONE T&P VALVE. FOR THE CSA RELIEF VALVE OPTION STARTING AT 700,000 BTU, A SECOND RELIEF VALVE WILL BE PROVIDED AS SHOWN.

SECTION 3: WATER HEATER INSTALLATION

3.1 Checking Equipment Before You Install

- Inspect the unit completely upon receipt from the freight carrier before signing the bill of lading. Inspect the appliance and all accompanying parts for signs of impact or mishandling. Verify the total number of pieces shown on packing slips with those received. Contact the freight carrier immediately if any damage or shortage is detected.
- Check the data decal on the appliance. Ensure the electrical, water, and gas supply is adequate for the installation.
- Carefully remove all side and top shipping supports and bracing. If possible, do not remove the wooden base/skid assembly until the product has been moved to its final location for installation and operation (see: Handling & Positioning).

3.2 Codes

Equipment shall be installed in accordance with local regulations. Consult with the appropriate authorities prior to installation. In the absence of such requirements, the installation must be in accordance with the instructions in this manual, appliance markings, and supplemental instructions and in compliance with the latest edition of the National Fuel Gas Code, ANSI Z223.1/NFPA 54. Where required by the Canadian authority having jurisdiction, the equipment must be installed in accordance with the latest edition of the CSA B149.1 Natural Gas and Propane Installation Code and applicable Provincial Regulations. All appliances conform to the current edition of the ASME Boiler and Pressure Vessel Code, Section IV, Part HLW.

3.3 Electrical Requirements

See the appliance rating decal for electrical service requirements. The appliance must be electrically supplied and grounded in accordance with the requirements of the authority having jurisdiction or, in the absence of such requirements, with the latest edition of the National Electrical Code ANSI/NFPA No. 70. In Canada, the electrical service must conform to local electrical codes and/or CSA C22.1, Canadian Electrical Code, Part 1.

- All wiring between the unit and field-installed devices must be made with properly rated stranded copper wire.
- Line voltage wire exterior to the appliance must be enclosed in approved conduit or approved metal clad cable.
- To avoid serious damage, DO NOT energize the unit until the system and appliance are full of water.
- Utiliser du fil de cuivre de la taille appropriée pour le service électrique entrant. Les dommages résultant de l'utilisation de fil d'aluminium seront exclus du champ d'application de la garantie de cet appareil.

3.4 Handling and Positioning

WARNING! When lifting this product, use industry-standard safe rigging methods, such as strapping the base/skid assembly and spreader bars. Failure to follow these methods can result in property damage, serious injury, or death. As with any electrical product, care should be taken to guard against the potential risk of fire, electric shock, and injury to persons.

1. The water heater must be located indoors unless it is the approved outdoor model identified by model suffix O.
2. This water heater can be installed directly on a combustible floor.
3. Locate the water heater in an area not exposed to freezing temperatures. For instructions on outdoor models, see section 18 of this IOM manual.
4. Locate on a level surface. Installation on a 4-inch to 6-inch housekeeping pad is recommended.
5. Install the water heater near a suitably sized floor drain. Locate the unit so that if the tank or water connections should leak, water damage will not occur to the adjacent area or the lower floors of the building. When such locations are unavoidable, install an adequately drained metal drain pan underneath the water heater. The manufacturer's warranty does not cover water damage.
6. Protect associated electrical components and connections from water (dripping, spraying, rain, etc.) during appliance operation and service.
7. Choose a location for the water heater where the vent and air intake piping will remain within the maximum equivalent lengths allowed when installed. See Venting.
8. When connecting the heater to the floor, locate anchors or attachment points using the following diagram. Commonly used concrete anchors are 5/16" x 1-3/4" double expansion shields.

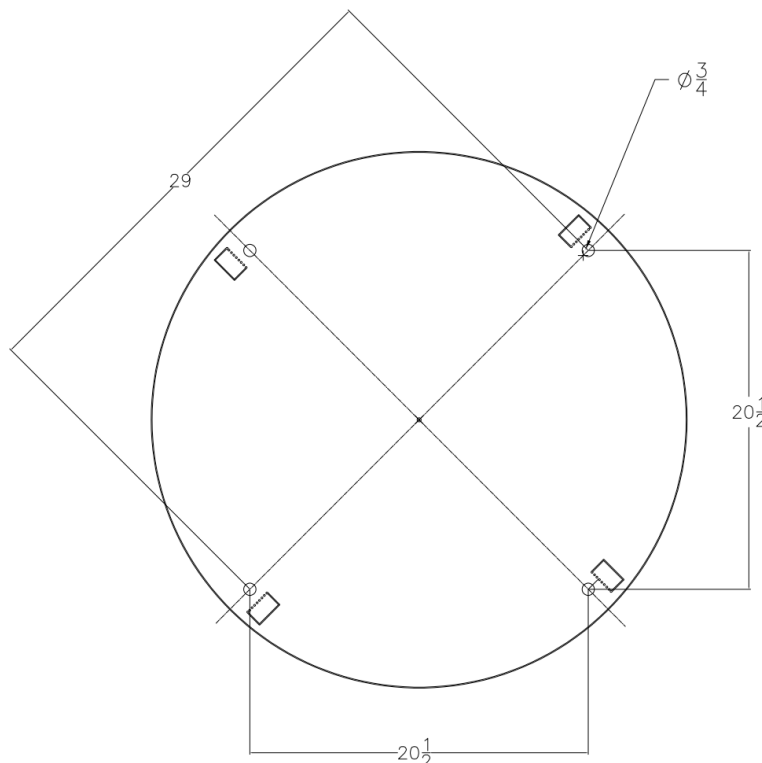

Figure 3-1: Front

3.5 Clearances To Combustible Surfaces

The minimum clearance to combustible material is 15" from the top, 24" from the front, and zero clearance (0") from the sides and back of the water heater. The Conquest can be installed directly on a combustible floor.

Distance minimale aux matériaux combustibles est égale à zéro (0 cm) sur les côtés et à l'arrière, avant les 61 cm, 38 cm de haut et peut être installé directement sur un plancher combustible.

3.6 Service Clearances

Additional clearance beyond the minimum required for combustible material should be considered to facilitate easy access for inspection and service of items such as the burner, gas controls, and plumbing connections. Also, allow sufficient space for installing and servicing building water, gas, vent, combustion air, electrical, pump, and other auxiliary/optional equipment and connections.

3.7 Other Code and Regulatory Clearances and Requirements

Additional clearance beyond the minimum required for combustible materials and other requirements may be necessary to comply with local, state, or national codes and regulations. It is the responsibility of the installer to comply with these requirements. Examples of codes or regulations that may apply are the National Electric Code, State/Regional/National drain water and flue emissions regulations, the National Fuel Gas Code, Building Construction and Safety Codes, the Americans with Disabilities Act (ADA) and, in states where a water heater above a specific input or storage capacity is considered a boiler, the applicable boiler code requirements, the applicable boiler installation requirements in "Safety Code for Controls and Safety Devices for Automatically Fired Boilers" (CSD-1) and other regulatory requirements.

SECTION 4: GENERAL PIPING GUIDELINES

WARNING: Hot outlet and cold-water piping materials connected to this product must be suitable for temperatures up to 212°F at normal operating water pressures.

4.1 Inlet and Outlet Connections

Use only non-ferrous water piping and fittings. Do not use galvanized pipes or fittings. The use of ferrous or galvanized pipes or fittings can cause rust to form.

Install shut-off valves and unions on the inlet and outlet water piping for servicing. Use caution when threading pipe nipples into tank connections to prevent cross-threading or over-tightening. Always use a backup wrench on tank nipples when tightening unions, valves, etc.

Insulate hot water and return circulation lines. If cold water supply lines are subject to freezing during shutdown periods, insulate them as well. **IMPORTANT:** Do not use the plumbing connected to the appliance as a ground for welding or any other purpose.

It is highly advised to use the building return. If not utilizing the return connection, install a plug.

Pipe the drain valve to a suitable open drain capable of receiving discharge temperatures up to 212°F.

IMPORTANT: The inlet water to the Conquest should not exceed 100°F for maximum efficiency. It is also recommended that the building return or dishwasher recirculation piping be connected to the return water connection located at the mid-tank and not to the cold inlet water supply. The Conquest utilizes cold inlet water to help extract almost all the heat energy from the combustion products, which lowers the vent temperature to allow the use of PVC vent pipe. Higher cold inlet water temperatures will reduce heater efficiency and increase the vent temperature. If the vent temperature approaches the maximum allowed, a vent temperature limit switch will cycle the heater off to protect the PVC vent. When high-temperature inlet water is applied, such as the Booster Heater Application described in section 4, follow the instructions for required venting selection and vent limit adjustment.

4.2 Building Return Piping

Do not connect the building return or dishwasher recirculation piping to maximize water heater efficiency directly to the cold inlet. Connect directly to the dedicated building return fitting located at the rear of the tank at mid-tank level (~ 5 gpm).

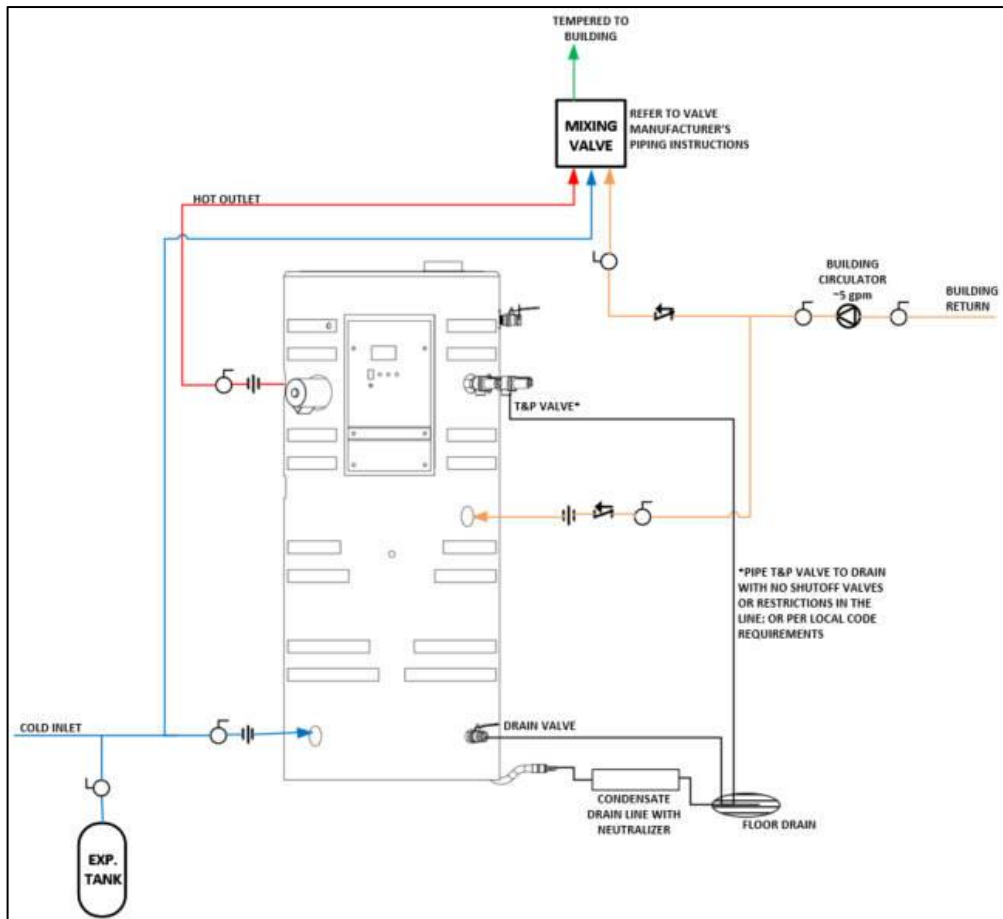

Figure 4-1: Single Water Piping

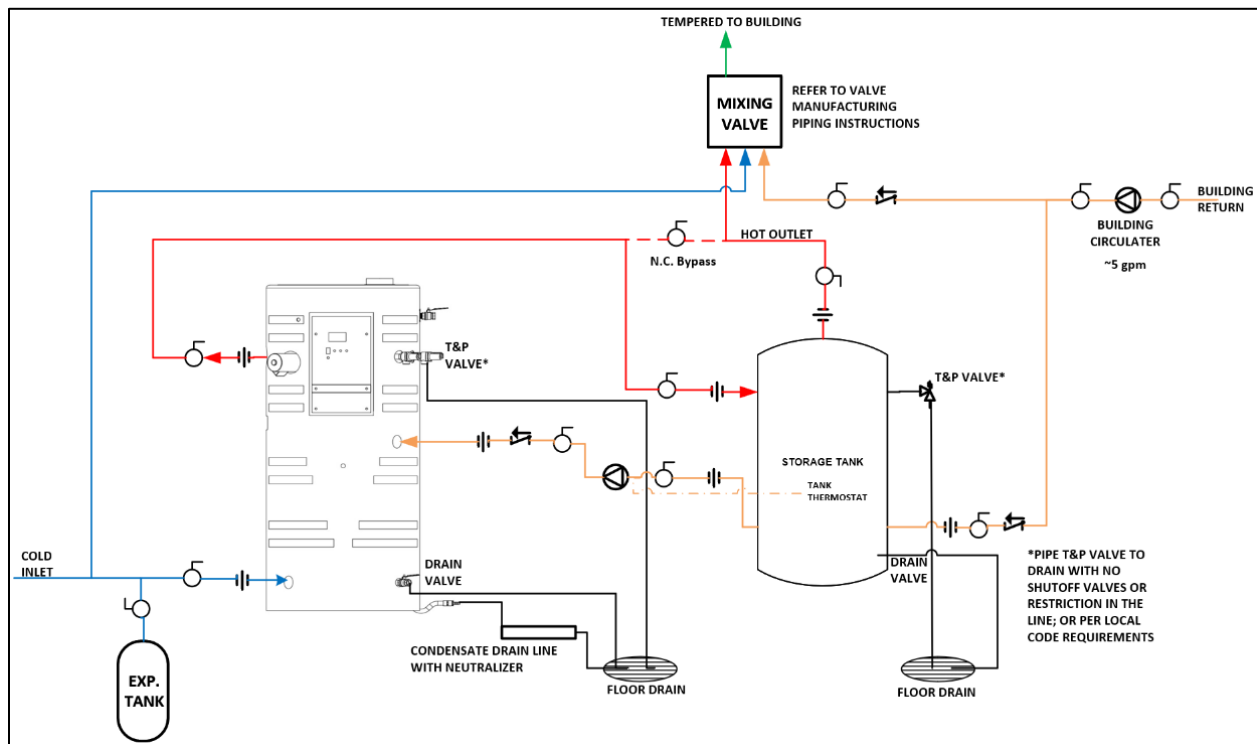

Figure 4-2: Single Storage Water Heater With Supplemental Storage Tank

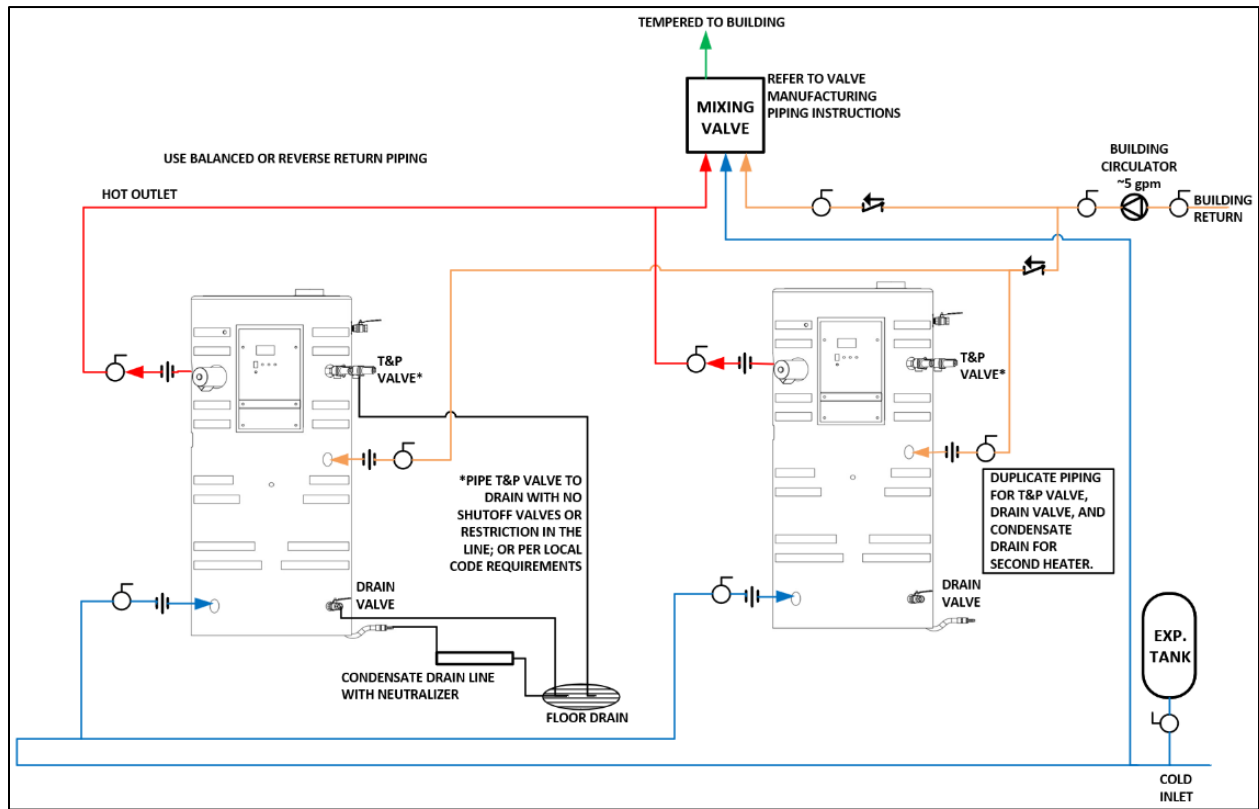
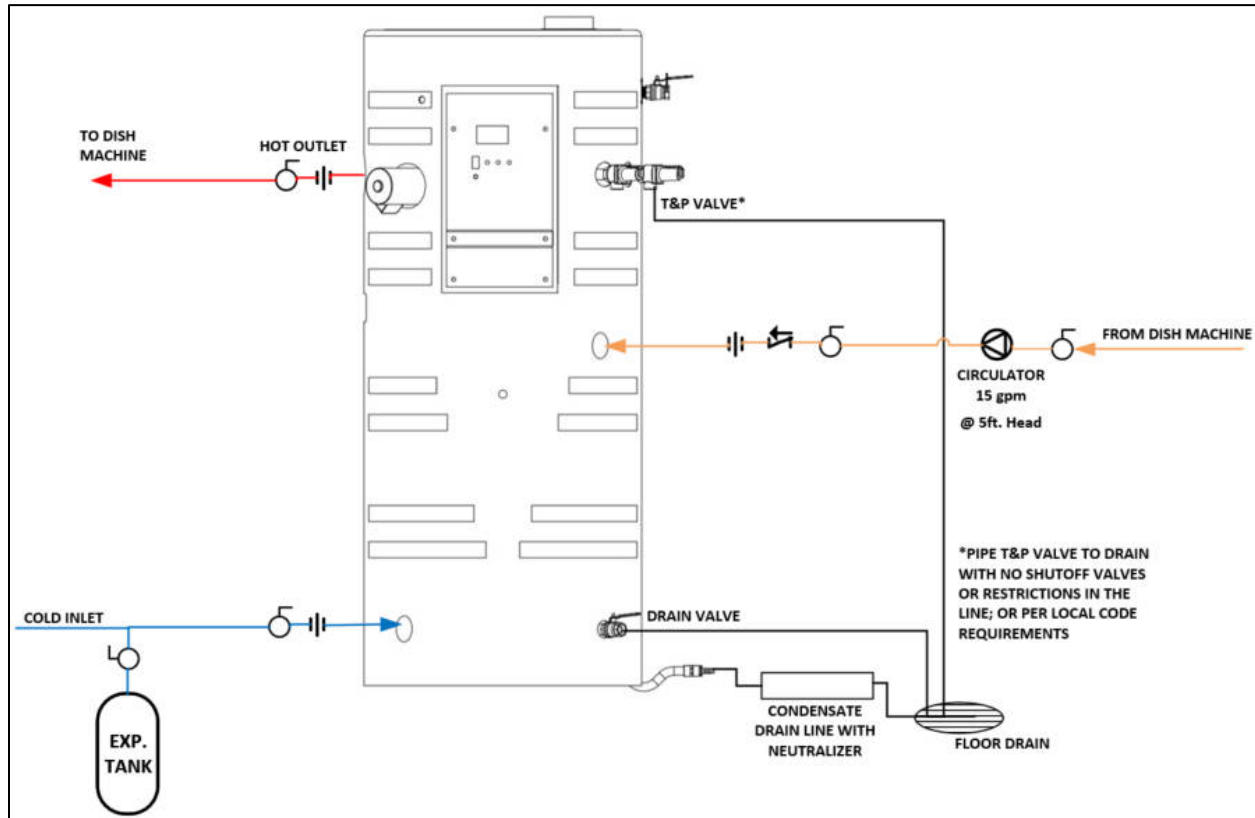

Figure 4-3: Two Water Heaters With Reverse Return Piping

4.3 Requirement for 180°F Delivered Water to a Dish Machine

When the Conquest water heater is used as the high-temperature water source for a dishwashing application, the application requirements and notes below must be followed.



4.3.1 Application Requirements and Notes

For Conquest applied as the high-temperature water source for a dishwashing application, follow all instructions in the “VENTING” and “GENERAL PIPING GUIDELINES” Sections of this manual, EXCEPT that:

1. These instructions are for operation with normal cold inlet water temperatures of less than or equal to 110°F. Contact the factory for inlet water temperatures above 110°F.
2. Solid PVC exhaust venting is acceptable for inlet water temperatures less than or equal to 100°F. If inlet water temperatures are above 100°F, solid CPVC, ETL, UL, ULC, or CSA-listed polypropylene or stainless-steel venting is required. The vent limit switch must be adjusted for the higher temperature rating these vent materials allow (Contact the factory for instructions).
3. Change the following EOS control settings on the Conquest water heater applied as the high-temperature water source for a dishwashing application:
 - a. Adjust the operating differential (DIFF) to 2°F.
 - b. Adjust the operating offset (OFFSET) to 3°F and
 - c. If the installed exhaust venting material is solid CPVC, ETL, UL, ULC, or CSA-listed polypropylene or stainless steel, adjust the vent limit switch (Contact the factory for instructions). Adjust these parameters in the Setup menu of the digital control display. These settings are used in most dishwashing applications but may require adjustment for optimal performance.

4. The application must include a 15 GPM circulation loop between the booster heater and the dish machine. A B&G NBF 22 pump with a minimum 1-inch pipe return to the heater is recommended.
5. All dishwashing machines meeting National Sanitation Foundation (NSF) requirements must operate between 15 and 25 PSI water flow pressure. Pressure-reducing or flow-regulating control valves in the hot water supply line to the dishwasher should be adjusted within these limits.

4.4 Booster Heater Applications

When the Conquest water heater is used as the high-temperature water heater in a booster heater application, the application requirements and notes below must be followed.

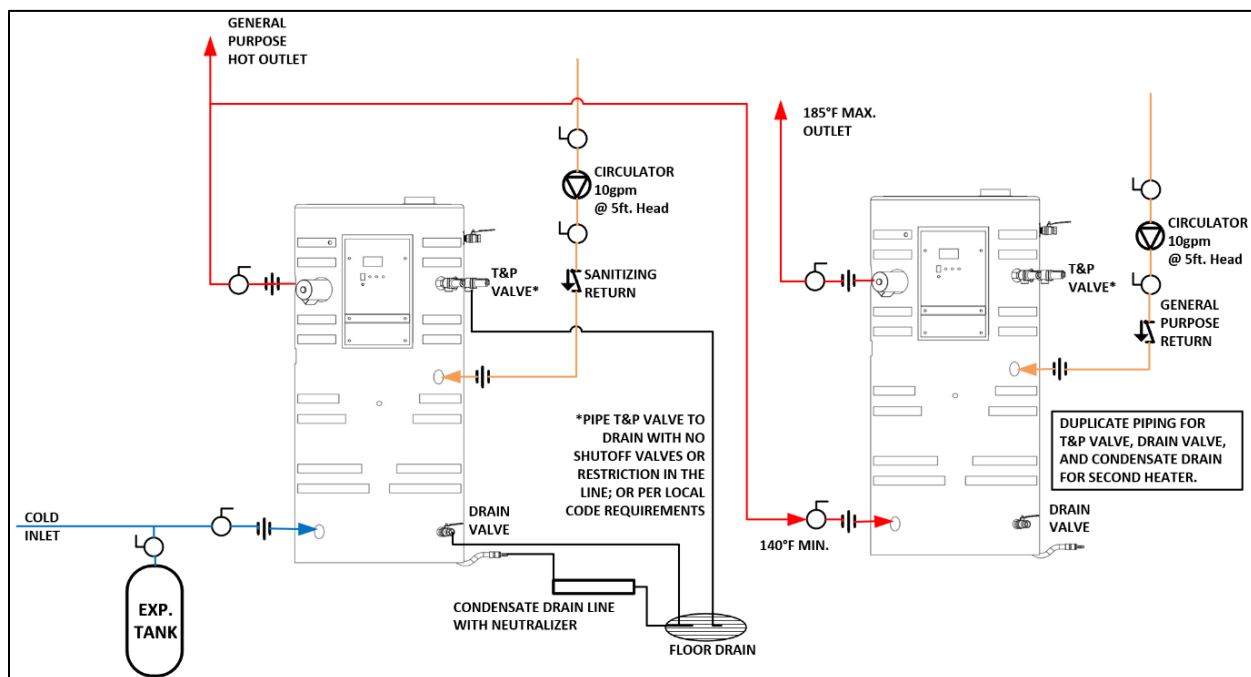

4.4.1 Application Requirements and Notes

For Conquest applied in a booster heater application, follow all instructions in Sections 4, 5, and 8 of this manual EXCEPT that:

1. When applied as a booster heater, the general-purpose water heater must supply the inlet with a minimum water temperature of 140°F. Contact the factory if the general-purpose water heater cannot supply a minimum water temperature of 140°F.
2. The booster heater requires a solid CPVC or ETL, UL, ULC, or CSA-listed polypropylene or Stainless-Steel venting system. If a concentric vent is used, it must be solid CPVC and terminated with an IPEX CPVC System concentric vent termination kit. The General-Purpose Water Heater has no special installation requirements when it supplies 140°F water to the booster heater's inlet.
3. When used as a booster heater, the vent limiting switch must be adjusted for the higher temperature rating allowed by using solid CPVC, polypropylene, or stainless-steel venting (Contact the factory for instructions).
4. Change the following EOS control settings on the Conquest water heater applied as a booster heater using the required CPVC or ETL, UL, ULC, or CSA-listed polypropylene or stainless-steel venting system:

- a. Adjust the operating differential (DIFF) to 2°F.
 - b. Adjust the operating offset (OFFSET) to 3°F and
 - c. Adjust the vent temperature limit switch (contact the factory for instructions). These parameters can be adjusted in the Setup menu of the control display. These settings are used on most booster heater applications but may require adjustment for optimal performance.
5. Install a 3/4" CPVC threaded pipe plug into the condensate outlet fitting near the vent connection. Do not use the supplied "P" trap. Since booster heater operation with an inlet water temperature of 140°F or higher does not result in condensate formation, no liquid is available to form the water seal in a "P" trap. Some flue gas can escape into the installed space without the water seal.
 6. The booster heater application must include a 10 GPM circulation loop between the booster heater and the dish machine. A B&G NBF 22 pump with a minimum 1-inch pipe return to the heater is recommended and is available from PVI.
 7. All dishwashing machines meeting National Sanitation Foundation (NSF) requirements must operate between 15 and 25 PSI water flow pressure. Pressure-reducing or flow-regulating control valves in the hot water supply line to the dishwasher should be adjusted within these limits.

SECTION 5: CONDENSATE DRAIN, TRAP & DISPOSAL

All Conquest water heaters, except those applied as a booster water heater (see Section 4.3 for booster instructions), are for operation with normal cold inlet water temperatures of less than or equal to 110°F and produce a significant amount of condensate. The condensate drain is under slightly positive flue pressure, so the provided 3/4" PVC condensate trap must always be used. This trap is sized and designed to fill with the proper amount of condensate to create a liquid barrier to prevent flue gases from escaping through the condensate drain into the installed space.

WARNING: The trap included with this unit must be installed and maintained as described in these instructions and must be included as part of the condensate piping system. This trap is required to keep potentially hazardous products of combustion from continually entering the installed space where the condensate piping terminates. Failure to properly install this trap can cause personal injury, exposure to hazardous materials, or death.

1. The condensate drain is located at the bottom rear of the water heater near the flue outlet. Connect the condensate trap assembly to the PVC fitting on the condensate drainpipe. Additional PVC fittings and pipe can be added to the condensate drain connection to relocate the condensate trap assembly as long as all added parts are at the same elevation. After attachment, the trap must be rotated so the pipe offset aims toward the floor. Do not rotate the offset toward the ceiling. Do not use tools to tighten the PVC union. Hand-tighten the PVC union to seat the internal gasket.
2. Do not combine condensate drains from multiple condensing appliances into a single drain line. Route each drain line into a drain suitable for condensate and ensure that the end of the drain lines is not submerged or otherwise blocked.
3. All condensate plumbing must be protected from freezing. Do not locate the condensate piping such that an ice dam of frozen condensate can block condensate from leaving the outlet.
4. The condensate is only slightly acidic (3-5 pH); however, local codes may require it to be neutralized before entering the drainage system. The factory offers an optional, field-installed Condensate Neutralization System.
5. Connect a condensate drain line or the PVI Condensate Neutralization System to the barbed hose connection, sized for 1" heavy wall Vinyl tubing rated for 170°F or higher (3/4"ID), located at the end of the condensate trap. All piping from the condensate trap to the suitable drain must remain below the highest point (top of the condensate outlet pipe) on the properly attached and primed condensate trap.

The condensate trap must be primed before the unit starts up. Priming a unit means adding water to the trap.

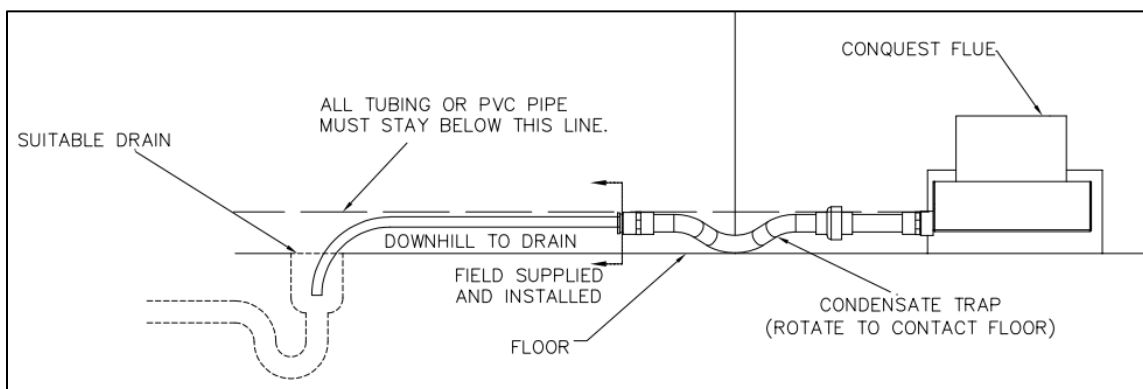

Figure 5-1: Condensate Trap Without Optional Condensate Neutralizer

5.1 Condensate Neutralization System (Optional)

Condensate is only slightly acidic (3-5 pH); however, this slight acidity can be neutralized by routing it through an optional PVI Condensate Neutralization System. Some “authorities having jurisdiction” require such neutralization before condensate disposal through a suitable drain. Condensate is neutralized while slowly flowing through a container filled with renewable neutralizing media. The condensate neutralizer reduces or avoids the need for separate chemical treatment or dilution using substantial quantities of tap water. If the Condensate Neutralization System is used, a maintenance interval of 3 months should include checking for adequate neutralization media, a fully closed system container, and any buildup of debris that could cause blockage in the system. Contact your local PVI representative to obtain a Condensate Neutralization System and follow the instructions included for assembly and connection.

Condensate Neutralization Systems (CNS) Installation Requirements:

1. Follow the steps in the Condensate Drain, Trap & Disposal section above.
2. The Condensate Neutralization System (CNS) must be mounted horizontally and level.
3. Locate the CNS in a convenient place between the condensate outlet and a suitable drain where the threaded end cap can be removed to recharge the Neutralizer. Use only the replacement materials specified by the CNS supplier.
4. The CNS must be located so that condensate flows downhill from the condensate trap outlet to the inlet on one end of the CNS and downhill from the other end of the CNS to the drain. If this continuous downhill flow is not maintained, the trap will not properly operate, and condensate could go back into the heater.
5. Follow the instructions in the Condensate Neutralization System for connecting the Vinyl tubing.
6. Keep the Condensate Neutralization System closed, except when the appliance is turned off for maintenance to recharge the condensate neutralizer with replacement media.

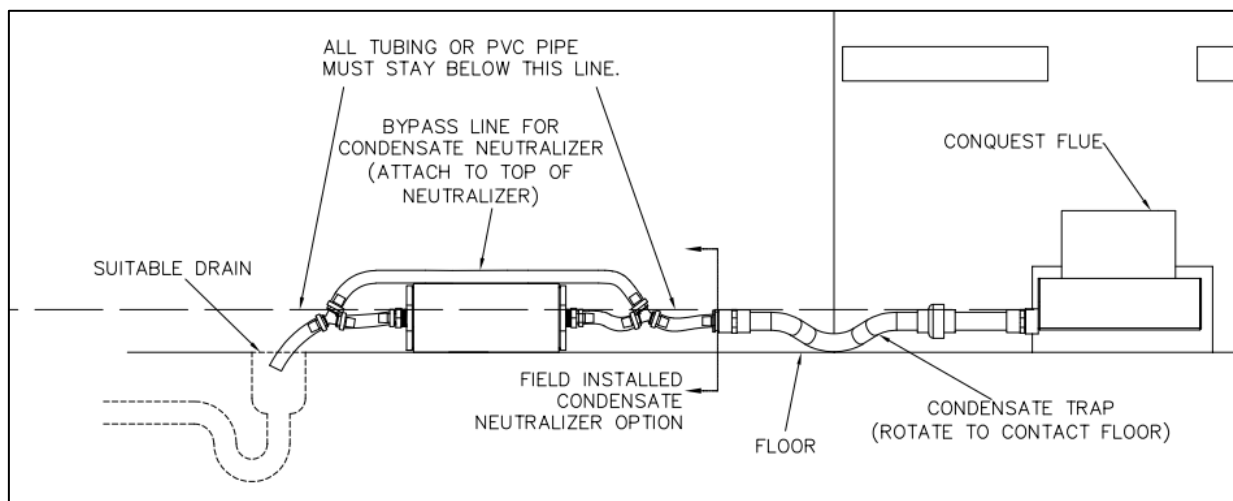

Figure 5-2 : Condensate Trap with Optional Condensate Neutralizer Located on the Same Level as the Conquest

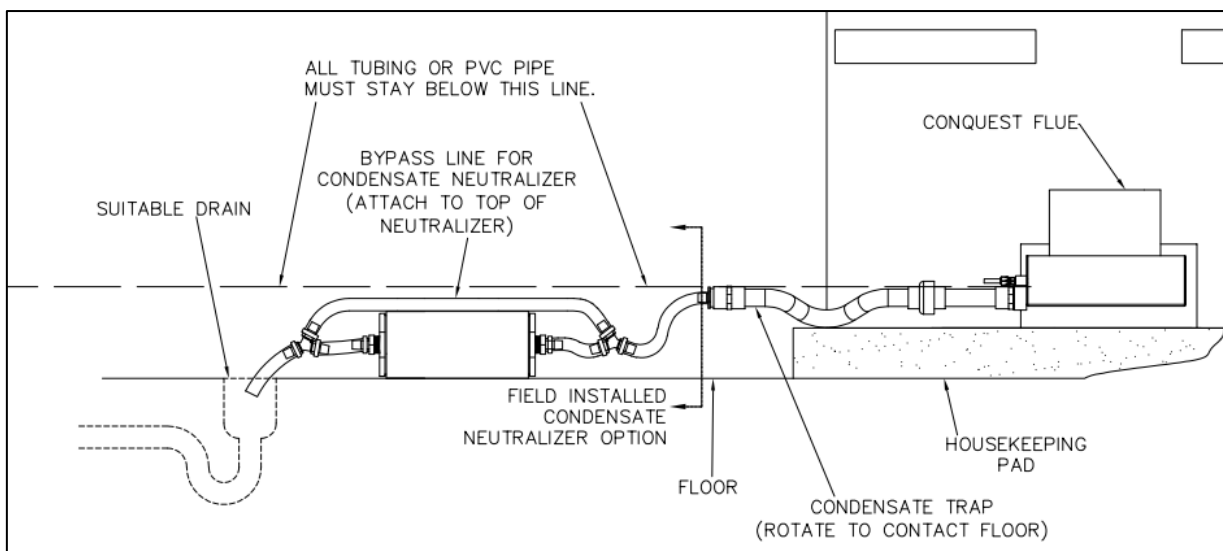

Figure 5-3: Condensate Trap with Optional Condensate Neutralizer Located Below Conquest

WARNING: Keep the Condensate Neutralization System closed while the appliance is operating. The system must remain closed to prevent potentially hazardous product combustion from continually entering the room. Failure to keep the Condensate Neutralization System closed during appliance operation can cause property damage, exposure to hazardous material, personal injury, or death.

SECTION 6: GAS SUPPLY AND PIPING

Verify the type of gas specified on the rating plate is supplied to the unit. This unit is designed for operation up to 2000 feet altitude. Appliance Btu/h input derates 4% per 1000 feet elevation above sea level. Consult the factory for installations above 2,000 feet.

6.1 Gas Train and Controls Certification

NOTE: The gas train and controls assembly provided on this unit have been tested under the applicable Nationally Recognized Standard to comply with safety and performance criteria such as ignition, combustion, and shutdown operation.

6.2 Gas Control Trains

All models include the following gas control train components: a manual shutoff valve, two safety shutoff valves, a zero governor type regulator, and a manual test valve. These components may be separate or combined in a common housing.

WARNING: Do not adjust or remove any screws or bolts on gas train control components which are secured with a red or blue sealing compound. In addition to voiding warranties and certification listings, such adjustment or disassembly can cause improper operation, resulting in property damage, personal injury, or death.

6.3 Inlet Pressure

Measure at the inlet pressure tap located at the main gas cock. The inlet pressure must remain within the minimum and maximum values while the unit is at rest and operating at the maximum firing rate. **Under no circumstance should the dynamic (flow) pressure drop be more than two inches below the supplied static pressure for either natural gas or propane.** Dynamic (flow) pressure is measured at the inlet pressure tap while the unit operates at the maximum firing rate.

INLET PRESSURE	NAT. GAS	Propane
Maximum Static Pressure (Inches-Water Column)	14.0"	13.0"
Minimum Flow Pressure (Inches-Water Column)	3.5"	8.0"

6.4 Gas Piping Size

Do not use the gas pipe connection size to determine the gas supply piping. Designing and sizing a gas supply piping system requires consideration of many factors and must be done by a gas supply piping expert. Always follow NFPA 54 National Fuel Gas Code for gas pipe sizing and gas pipe system design. The following charts provide examples of some of the information used by the gas supply piping expert to determine proper pipe sizes.

Use the values in the following table to add the equivalent straight pipe for each elbow or tee to obtain the total distance from the meter:

CONVERT FITTINGS TO EQUIVALENT STRAIGHT PIPE*								
Diameter Fitting (inches)	3/4"	1"	1 1/4"	1 1/2"	2"	3"	4"	5"
Equivalent Length of Straight Pipe (feet)	2'	2'	3'	4'	5'	10'	14'	20'

Use the following table to determine the possible pipe size based on distance from the gas meter for a Single Unit Installation using Schedule 40 Metallic Gas Pipe. *

SINGLE UNIT INSTALLATION – POSSIBLE SCHEDULE 40 METALLIC GAS PIPE SIZE*					
Distance from the meter in equivalent feet of schedule 40 metallic gas pipe. *Based on inlet pressure less than 2 psi, specific gravity of 0.60, and a pressure drop of 0.5 in. W.C.					
MODEL	0' - 10'	11' - 25'	26' - 50'	51' - 100'	101' - 200'
400	1"	1"	1-1/4"	1-1/4"	1-1/2"
500	1"	1-1/4"	1-1/4"	1-1/2"	2"
600	1"	1-1/4"	1-1/4"	1-1/2"	2"
700	1-1/4"	1-1/4"	1-1/2"	2"	2"
800	1-1/4"	1-1/4"	1-1/2"	2"	2-1/2"
900	1-1/2"	1-1/2"	1-1/2"	2"	2-1/2"
1000	1-1/2"	1-1/2"	2"	2"	2-1/2"
1100	1-1/2"	1-1/2"	2"	2"	2-1/2"
1200	1-1/2"	2"	2"	2-1/2"	2-1/2"

*See NFPA 54 National Fuel Gas Code for actual pipe size selection and for sizing Propane gas piping.

MULTIPLE UNIT INSTALLATIONS SCHEDULE 40 METALLIC GAS PIPE SIZE CHART*														
Maximum Capacity of Pipe in Thousands of Btu's per hour for gas pressures of 14 Inches Water Column (0.5 psig) or less and a pressure drop of 0.05 Inch Water Column (Based on NAT GAS, 1025BTU per Cubic Foot of Gas and 0.60 Specific Gravity).*														
Nominal Iron Pipe Size, Inches	Length of Pipe in Straight Feet													
	10	20	30	40	50	60	70	80	90	100	125	150	175	200
3/4	369	256	205	174	155	141	128	121	113	106	95	86	79	74
1	697	477	384	328	292	267	246	256	210	200	179	164	149	138
1 1/4	1400	974	789	677	595	543	502	472	441	410	369	333	308	287
1 1/2	2150	1500	1210	1020	923	830	769	707	666	636	564	513	472	441
2	4100	2820	2260	1950	1720	1560	1440	1330	1250	1180	1100	974	871	820
2 1/2	6460	4460	3610	3100	2720	2460	2310	2100	2000	1900	1700	1540	1400	1300
3	11200	7900	6400	5400	4870	4410	4000	3800	3540	3300	3000	2720	2500	2340
4	23500	16100	13100	11100	10000	9000	8300	7690	7380	6870	6150	5640	5130	4720

*See NFPA 54 National Fuel Gas Code for actual pipe size selection and for sizing Propane gas piping.

6.5 Appliance Isolation during Gas Supply Piping Pressure Test

1. IMPORTANT - The appliance and its manual shutoff valve must be disconnected from the gas supply piping system during any pressure testing of that system at test pressures greater than 1/2 psi (3.5 kPa).
2. The appliance must be isolated from the gas supply piping system by closing its manual shutoff valve during any pressure testing of the gas supply piping system at test pressures equal to or less than 1/2 psi (3.5 kPa).
3. The appliance and its gas connection must be leak-tested before placing it in operation.

6.6 Gas Connection

1. The safe operation of the unit requires an adequate gas supply with the required static and dynamic (flow) pressures. The gas piping system designer must carefully consider many variables when selecting the actual piping.
2. Do not select gas pipe sizes based only on the supplied tables. These tables are for the gas piping system designer to reference when checking pipe size selections.
3. The gas pipe size may be larger than the heater connection.
4. Installation of a union is suggested for ease of service.
5. Install a manual main gas shutoff valve on the gas supply piping connected to the appliance to isolate the burner and gas train from the main supply gas in compliance with NFPA 54, the National Fuel Gas Code, and most local Codes.
6. The gas system installer must identify the emergency shut-off device.
7. A sediment trap (drip leg) MUST be provided in the inlet of the gas connection to the unit.
8. Conquest combination gas valves and/or gas regulators incorporate either an internal vent limiter or an externally mounted vent limiting orifice and 1/4" aluminum tube located in a "T" attached to the regulator vent port. Venting outdoors is not required. Never remove, cut, splice, or alter the flexible tubing connected directly to the regulator vent port or to a vent limiting fitting attached externally to the regulator, as this will cause unreliable ignition and can cause improper operation. Although not required, a connection to the open end of the 1/4" aluminum tube can be made and routed to the outdoors. No other connection point is allowed. Do not remove the aluminum tubing and connect directly to the "T", as damage to the required vent limiter and improper gas control could result.
9. All Conquest models incorporate a combination gas valve/regulator, which includes two dual internal safety valves.

SECTION 7: COMBUSTION SUPPLY AIR

Provisions for adequate combustion and ventilation air to the mechanical room must be in accordance with Section “Air for Combustion and Ventilation” in the latest edition of the NFPA 54 National Fuel Gas Code, ANSI Z223.1 and/or CSA B149.1, Natural Gas and Propane Installation Code or applicable provisions of the local building codes and this document.

NOTE: It is not permissible to use plenum/louvers for individually ducted intake air without individual dampers.

7.1 Equipment Located in Confined Spaces

Equipment located in confined spaces requires two openings, one commencing within 12" (30.5 cm) from the top of the enclosure/room and one commencing within 12" from the bottom of the enclosure/room to ensure adequate combustion air and proper ventilation. The total input of all gas utilization equipment installed in the room must be used to determine the required minimum air volume needed for combustion, ventilation, and dilution of flue gasses. Also, consider makeup air requirements from other equipment within the mechanical room or other rooms that are pressure-connected with the mechanical room. Some examples of other makeup air requirements are from kitchen exhaust hoods, clothes dryers, powered exhaust fans, etc.

All Air from Outdoors:

If the enclosure's appliances are directly communicating with the outdoors or communicating to the outdoors through vertical ducts, each opening requires a minimum free area of 1 square inch per 4000 Btu/hr of the total input rating of all appliances in the enclosure.

If communicating with the outdoors through horizontal ducts, each opening requires a minimum free area of 1 square inch per 2000 Btu/hr of the total input rating of all appliances in the enclosure.

All Air from Inside the Building:

Follow NFPA 54 National Fuel Gas Code, ANSI Z223.1 “Indoor Combustion Air”.

Combination Of Air from Indoors and Outdoors:

Follow the requirements of NFPA National Fuel Gas Code, ANSI Z223.1 section “Combination Indoor and Outdoor Combustion Air”.

From Outdoors Through One Opening:

Follow NFPA National Fuel Gas Code, ANSI Z223.1 section “One Permanent Opening Method”.

NOTE: This unit may be installed with a remote air intake system which uses a make-up air duct to draw combustion air directly from outdoors.

WARNING: Adequate clean combustion air must be provided to the appliance. The appliance must never operate under negative pressure. Care must be taken when exhaust fans, compressors, air handling units, etc., rob air from the appliance. The combustion air supply must be completely free of any chemicals or fumes that may be corrosive to the appliance. Some common chemical fumes to avoid are fluorocarbons and other halogenated compounds, most commonly present as refrigerants or solvents, such as Freon, trichloroethylene, perchloroethylene, chlorine, etc. These chemicals, when in contact with the equipment or when burned, form acids that quickly attack the tubes, flue collector, stack, and other appliance and auxiliary equipment. Failure to provide adequate clean combustion air or operating under negative pressure can cause premature, unwarranted product failure or unsafe operation, producing carbon monoxide that could escape into the building. Exposure to carbon monoxide can lead to personal injury or death.

7.2 Maximum Remote Combustion Air Inlet Length (Equivalent)

A vertical or horizontal remote air inlet system can be connected to this appliance without modification. The maximum length of field-supplied single wall pipe, such as galvanized ventilation pipe, is shown in the chart below titled Maximum Air Inlet Duct Equivalent Length. Use metal tape or RTV sealant to seal each pipe joint.

Maximum Air Inlet Duct Equivalent Length / Max Elbows		
Duct Size	6" Duct	8" Duct
Max Equivalent Length Model 400 – 500	200 feet / 10	300 feet / 10
Max Equivalent Length Model 600 – 800	250 feet / 10	300 feet / 10
Max Equivalent Length Model 900 – 1000	150 feet / 5	250 feet / 10
Max Equivalent Length Model 1100 - 1200	100 feet / 5	200 feet / 5

To determine the maximum straight length of duct allowed, use the Duct Fitting Equivalent Length chart below to find the total equivalent length for all duct fittings in your combustion air system. Then subtract this number of feet from the total equivalent length allowed in Maximum Air Inlet Duct Equivalent Length chart above. The sum of this calculation is the maximum length of straight duct allowed. If a longer length is required, repeat the calculation using a larger duct size. No additional deduction is required for the addition of the duct system terminal.

Duct Fitting Equivalent Length for Model 400 – 500	
Duct Pipe:	6" Duct
90° Elbow	10 feet
90° Long Radius Elbow	6 feet
45° Elbow	6 feet

Duct Fitting Equivalent Length for Model 600 – 1200		
Duct Pipe:	6" Duct	8" Duct
90° Elbow	20 feet	10 feet
90° Long Radius Elbow	12 feet	6 feet
45° Elbow	12 feet	6 feet

The following remote air duct information is provided for use in design calculations, if needed.

Remote Air Duct Specifications	
Input MBtu/h	Required Air (SCFM)
399	87
500	108
600	130
700	152
800	173
900	195
1000	216
1100	237
1200	259

7.3 Remote Combustion Air Cap

A suitable remote air termination must be used to prevent water, debris, animals, or obstructing material from entering the remote air supply.

7.4 Vertical or Horizontal Remote Air Duct Termination

- Air inlet must be located no less than 3 feet (0.91m) below the exhaust terminal if they are within 10 feet (3.05 m) of each other unless the flue outlet terminates with a straight discharge. If the flue outlet terminates with a straight discharge, the air inlet can be located no less than 18 inches (0.46m) below the exhaust terminal.
- If terminating through the roof, the air inlet must terminate at least 12 inches (0.3 m) above roof level and at least 12 inches (0.3 m) above snow levels.
- If terminating through a sidewall, the air inlet must terminate at least 12 inches (0.3 m) above grade and/or at least 12 inches (0.3 m) above possible snow levels.

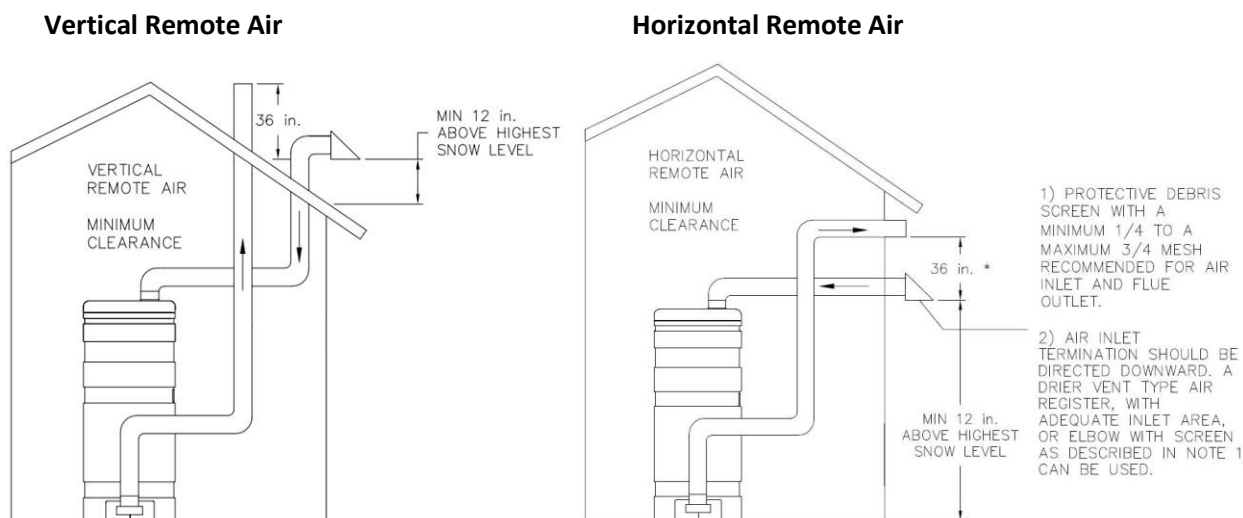

* When the flue outlet is terminated with a straight discharge, the terminations must be separated by at least 18".

7.5 Combining Remote Air Ducting

Each water heater **MUST** have separate intake piping, unless the air inlet piping, exhaust duct and other system considerations have been fully evaluated and a combined duct system designed by US Draft or other vent manufacturer with appropriate design capabilities. Before the operation of a combined remote air ducting system, all the duct design firm's system installation and operation requirements must be in place, their instructions followed, and the system must be properly maintained.

Combined Conquest air intake piping must incorporate a variable-speed blower capable of providing and regulating positive-pressure air supplied to all water heaters in the system. The pressure of the supplied air must be at least 0.0" W.C. and **not exceed 0.25" W.C.**

The common combustion air supply system must be interlocked, so the water heaters will not begin operation until the common combustion air supply is proved to be within the range of 0.0" W.C. to 0.25" W.C. See Section on **Remote Connections** for a discussion of how to connect the proving circuit.

WARNING: Do not combine remote air ducting of multiple appliances into a single remote air duct unless the combined remote air ducting system has been evaluated and designed by a specified duct design firm and the combined remote air duct system is installed, operated, and maintained following instructions from that firm. Combining remote air ducting without following these requirements can result in failure of the water heater and venting system and/or exposure to carbon monoxide and can result in property damage, personal injury, or death.

7.6 Optional Filter Box for Dusty or Dirty Combustion Air

The field-installed optional air inlet filter box must be attached to the combustion air inlet on any appliance located where it is exposed to dusty, dirty, or lint-filled combustion air. Replace the filter on a 3-to-6-month schedule, or more often, based on the severity of contamination. Inadequate combustion air or non-combustible particulate matter such as dust, dirt, dryer lint, concrete dust, drywall dust, or the like can be drawn in with combustion air and block burner ports. This can cause unreliable operation and non-warrantable failures. When the optional field installed filter box is required, do not operate the appliance without a suitable filter. See the following illustration for filter and filter box kit part numbers and installation instructions. Outdoor units (model suffix O) have an integral combustion air filter, and the optional filter box is not required.

Filter Box Installation

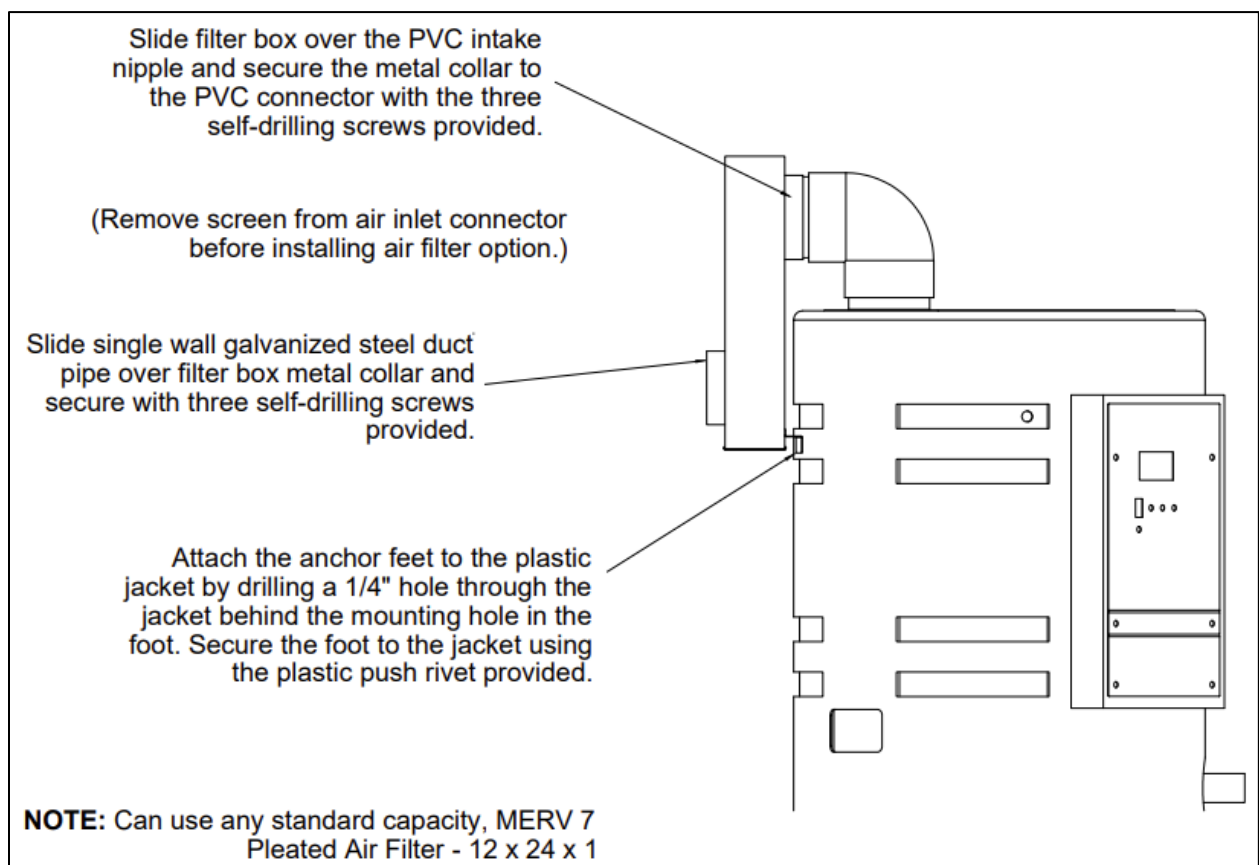

NAME	DESCRIPTION
164624	FILTER KIT
110265	REPLACEMENT FILTER
69702	90 DEG 6-IN OD PVC ELBOW
127690	NIPPLE, PVC 6-IN OD X 4-IN

SECTION 8: VENTING

Provisions for adequate exhaust from gas-fired equipment must be in accordance with the latest edition of the NFPA 54 National Fuel Gas Code, ANSI Z223.1 and/or CSA B149.1, Natural Gas and Propane Installation Code or applicable provisions of the local building codes, and this document.

8.1 Venting the CONQUEST:

All Conquest models use the positive pressure generated by the burner system blower to push combustion products out of the vent. Because the vent system is under positive pressure and must be capable of containing condensate, it must be constructed of schedule 40 solid PVC or CPVC pipe. Polypropylene or single or double-wall stainless steel venting is recommended. All materials must be listed by ETL, UL, ULC or CSA for Category IV positive pressure gas appliance venting may be used instead of solid PVC or CPVC plastic pipe venting.

IMPORTANT: If the cold inlet water temperature is above 100°F, solid CPVC or ETL, UL, ULC, or CSA-listed polypropylene or stainless-steel venting is required. The vent limit switch must be adjusted for the higher temperature rating allowed by these vent materials. (See Section 10.6—Changing the Vent Material Type.)

Utilisez une catégorie IV PVC, CPVC ou ETL, UL, ULC ou CSA acier inoxydable ou inscrits conduit d'évacuation en polypropylène. Ne sélectionnez pas la taille du tuyau de ventilation basée uniquement sur le diamètre raccord de l'appareil.

In addition to the vent manufacturer's instructions, when using solid PVC or CPVC, additional instructions are provided below. For other listed vent materials, follow the vent manufacturer's instructions for installation, sealing, supporting, and terminating their vent system. Covering non-metallic vent pipes and fittings with thermal insulation is prohibited.

The stainless-steel vent connection located near the front of the water heater is 6-5/8-inch O.D. to accept a 6-inch PVC or CPVC pipe coupling. A reducer coupling may also be used to accommodate smaller or larger vent pipes (See Maximum Vent Length tables). Do not use a barometric damper with the Conquest positive-pressure vent. The minimum vertical duct length from the vent connection should be 24 inches.

The Conquest water heater can be vented either vertically, through a ceiling or roof, or horizontally through a wall. The Conquest is a Category IV positive pressure gas appliance venting and can be routed to the outdoors in any direction from the flue outlet of the water heater except down. The vent must be installed and supported at least every four feet to slope downward toward the water heater vent connection with at least a 1/4-inch drop per linear foot of horizontal vent run to allow proper drainage of accumulated condensation. The venting system shall also have a means for the collection and disposal of condensate. All penetrations through walls and roofs must be weather and gas-tight, such that rain and products of combustion cannot pass from outdoors back indoors.

Additional steps required when venting with solid PVC or CPVC pipe:

1. Read and follow the information, instructions, and warnings in the “VENTING” section.
2. Do not insulate the plastic vent pipe.
3. Design the vent pipe route so that normal expansion (pipe getting longer) and contraction (pipe getting shorter) due to on- and off-temperatures do not bind or stress cemented pipe fittings.
4. A 6-inch pipe coupling must always be the first fitting attached to the Conquest vent connection when using a PVC or CPVC vent system. If a listed stainless steel or polypropylene Category IV vent system is used, the correct adapter for attaching and sealing to the Conquest 6-5/8-inch O.D. vent connection must be obtained from the manufacturer of the vent system to be installed.

5. For PVC or CPVC, dry-fit the 6" pipe coupling onto the Conquest vent connector. Then, remove the coupling and apply a liberal coating of room-temperature vulcanizing (RTV) adhesive to the outside of the vent connector and to the inside of the plastic pipe coupling. Before the RTV sets, slide the coupling over the vent connector while rotating approximately 1/8 of a turn. Inspect and apply additional RTV to the joints, if needed, to provide a sound air and watertight seal.
6. Drill a pilot hole through the PVC or CPVC coupling flange and into the center of the stainless-steel vent connector flange in three equally spaced locations around the pipe. Drive stainless steel sheet metal screws through the pilot holes to attach and firmly hold the plastic coupling onto the vent connector flange.
7. Clean and deburr all solid PVC or CPVC pipe ends, then trial assemble the entire vent system vent before joining with cement. Mark the pipe and fittings to identify their locations, then disassemble. Reassemble the vent system using fresh PVC cement to connect the PVC pipe and fresh CPVC cement to connect the CPVC pipe. If both solid PVC and solid CPVC pipes are used in the same vent system, all joints between the two types of pipes must be made with fresh cement suitable for both materials. Follow the cement manufacturer's instructions for making sound air and watertight joints.
8. Vent support—For PVC or CPVC, the vent system must be supported at intervals no greater than four feet to prevent sagging, distortion, and stress on pipe fittings. Vertical pipe must also be supported to avoid stress on all cemented pipe fittings and to prevent excessive weight on the appliance vent connection. For listed stainless steel or polypropylene vent systems, follow the vent system manufacturer's instructions.
9. Testing for leaks – Once the vent system is installed, it must be checked to confirm all joints in the vent system are air and watertight. After the vent is assembled, close the end of the vent with a taped plastic bag or some other temporary closure. With the gas supply turned off, energize the Conquest combustion blower to apply air pressure to the vent system. Spray each joint and vent connection with commercially available leak detection liquid to confirm no air is escaping from any point. Repair any leaks and retest. After testing is complete, de-energize the combustion blower, wipe clean the leak detection liquid, and REMOVE the temporary vent closure.
10. The vent pipe must be sealed at the point where it passes through a wall or roof to prevent rain, insects, or flue products from entering the living space or interior of the building.
11. For proper vent operation and to protect the gas vent from wind and weather. Provide suitable termination to prevent wind, water, debris, or animals from obstructing or entering the vent. The vent for this appliance shall not terminate:
 - a. over public walkways; or
 - b. near soffit vents or crawl space vents or other areas where condensate or vapor could create a nuisance or hazard or cause property damage; or
 - c. where condensate vapor could cause damage or could be detrimental to the operation of regulators, relief valves, or other equipment.
12. Do not use a barometric damper with the Conquest venting system. Barometric dampers are designed for use with certain Category I negative pressure vent systems. The Conquest uses certain Category IV positive pressure vent systems and will not operate safely with a barometric damper.

WARNING: Use only solid PVC or CPVC pipe or use Polypropylene or stainless-steel venting (single or double wall) listed by a nationally recognized testing laboratory for Category IV positive pressure gas appliance venting. Use of cellular core PVC (ASTM F891), cellular core CPVC, or Radel® (polyphenylsulfone) in nonmetallic venting systems is prohibited. Use of ABS pipe, or use of PVC or CPVC pipe with cell/foam type construction, or use of venting materials other than

specified can result in failure of the venting system and/or exposure to carbon monoxide or other toxic fumes, which can result in property damage, personal injury, or death.

WARNING: Do not vent this water heater into an existing or traditional gas vent or chimney, do not combine the vent with any other appliance, and do not use a barometric damper in the vent. Such venting could result in failure and/or exposure to carbon monoxide, which can result in property damage, personal injury, or death.

8.2 Maximum Vent Length (Equivalent Length)

The maximum length of field supplied Category IV vent is shown in the chart below:

Maximum Allowable Equivalent Vent Length / Max Elbows			
Duct Size	4" Duct	6" Duct	8" Duct
Max Equivalent Length Model 400	125 feet / 4	200 feet / 10	300 feet / 10
Max Equivalent Length Model 500	80 feet / 3	200 feet / 10	300 feet / 10
Max Equivalent Length Model 600 – 800	N/A	250 feet / 10	300 feet / 10
Max Equivalent Length Model 900 – 1000	N/A	150 feet / 5	250 feet / 10
Max Equivalent Length Models 1100 – 1200	N/A	100 feet / 5	200 feet / 5

Pipe fittings reduce the maximum allowable vent length. Use the Category IV vent manufacturer's equivalent length deduction for all elbows, terminations, etc. If the information is not readily available from the vent manufacturer, use the Vent Fitting Equivalent Length chart below to find the total equivalent length for all vent fittings in your combustion air system. Then subtract this number of feet from the total equivalent length allowed in the Maximum Category IV Vent Equivalent Length chart above. The sum of this calculation is the maximum length of straight vent allowed. If a longer length is required, repeat the calculation using a larger vent size. When using this chart, no additional deduction is required for the addition of the vent system terminal. The minimum vent length should be five feet without the addition of elbows or other fittings.

Vent Pipe Fitting Equivalent Length for Models 400 – 500					
Vent Pipe:	PP* 4" Vent	Other ** 4" Vent	PP* 6" Vent	Other ** 6" Vent	8" Vent
90° Elbow	20 feet	18 feet	12 feet	10 feet	5 feet
90° Long Radius Elbow	12 feet	10 feet	7 feet	6 feet	3 feet
45° Elbow	12 feet	10 feet	7 feet	6 feet	3 feet

*PP = polypropylene ** Other = PVC, CPVC or Stainless Steel

Vent Pipe Fitting Equivalent Length for Models 600 – 1200			
Vent Pipe:	PP * 6" Vent	Other ** 6" Vent	8" Vent
90° Elbow	22 feet	20 feet	10 feet
90° Long Radius Elbow	14 feet	12 feet	6 feet
45° Elbow	14 feet	12 feet	6 feet

*PP = polypropylene ** Other = PVC, CPVC or Stainless Steel

The following vent information is provided for use in design calculations if needed:

Venting Specifications		
Input MBtu/h	Combustion Air Volume (cfm)	Max Vent Press. " W.C.
399	136	0.5
500	170	0.5
600	205	0.5
700	239	0.5
800	273	0.5
900	307	0.5
1000	341	0.5
1100	375	0.5
1200	409	0.5

8.3 Vertical or Horizontal Vent Termination:

1. The vent terminal must have a minimum clearance of 4 feet (1.22 m) horizontally from, and in no case be located above or below, unless a 4 foot (1.22 m) horizontal distance is maintained from electric meters, gas meters, regulators, and relief equipment.
2. The vent cap must terminate at least 3 feet (0.91 m) above forced air inlets within 10 feet (3.05 m).
3. The vent shall terminate at least 4 feet (1.22 m) below, 4 feet (1.22 m) horizontally from or 1 foot (0.3 m) above any door, window, or building air inlet to the building.
4. The vent system shall terminate at least 1 foot (0.3 m) above grade and at least 1 foot (0.3m) above possible snow accumulation levels and shall terminate at least 7 feet (2.13 m) above grade when located adjacent to public walkways or gathering areas.
5. To avoid a blocked flue, keep the vent cap clear of snow, ice, leaves, debris, etc. Periodically, inspect the screens in vent termination to clear debris.
6. The vent must not exit over a public walkway, within 10 feet of soffit vents or crawl space vents, or within 4 feet of areas where condensate or vapor could create a nuisance, a hazard, cause property damage, or could be detrimental to the operation of regulators, relief valves or other equipment.
7. A horizontal vent must extend one foot beyond the wall and terminate at least two feet above the maximum expected snow accumulation.
8. A horizontal vent terminal must be installed no closer than 3 feet (0.91m) from the inside corner of an L-shaped structure.
9. A vertical vent must exhaust outside the building at least 3 feet (0.91m) above the point of the exit and at least 2 feet (0.61 m) above the highest point of the roof within a 10-foot (3.05 m) radius of the termination.
10. A vertical termination less than 10 feet (0.91 m) from a parapet wall must be a minimum of 2 feet (0.61 m) higher than the parapet wall.
11. Recommended to use an exit cone in lieu of a termination rain cap for normal installations and T-termination for high-wind areas.
12. Gooseneck terminations are prohibited for all Conquest models.

8.4 Combining Category IV Vents

1. Combined Conquest Category IV gas vent systems must incorporate a variable speed, modulating, mechanical draft inducer capable of maintaining the appropriate negative pressure at the end of the common flue to ensure that all water heaters in the combined vent system operate with a negative draft. The draft must be provided by USDraft or other vent manufacturers with appropriate design capabilities. The venting system must be fully evaluated by the vent manufacturer or venting consultant. Do not exceed negative 0.25" W.C. See "Combining Vents with a Draft Inducer" illustration below.
2. Combining the exhaust vents of multiple Conquest condensing water heaters into a common, unpowered, or "gravity" vent is never recommended (i.e., venting as Category II).
3. The common mechanical draft vent system must be interlocked, so the water heaters will not begin operating until the negative pressure of the common mechanical draft vent system is proven to be within the range of 0.04" and 0.25" W.C. See the Section on Remote Connections for instructions on connecting the proving circuit. When combining the exhausts of multiple Conquest water heaters, do not use individual remote ducts to provide outdoor combustion air.
4. When exhaust vents are combined, it is necessary to either:
 - a. Draw all combustion air for each heater from the mechanical room in which they are installed, or
 - b. Use a common air supply system that is designed and installed by a qualified professional firm and that meets all the requirements contained in Subsection Combining Remote Air Ducting, located in the COMBUSTION AND VENTILATION AIR Section of this manual.

WARNING: Do not connect multiple water heater vents into a single unpowered or fixed-speed powered vent. This could cause unsafe operation and the potential for poisonous carbon monoxide to enter occupied areas. Such improper installation can cause property damage, exposure to hazardous materials, personal injury, or death.

Conventional Venting

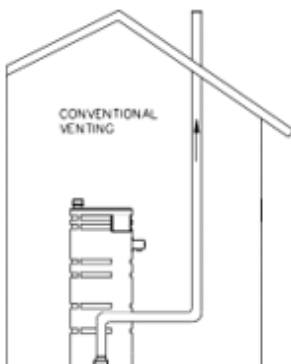

Through the Wall Venting

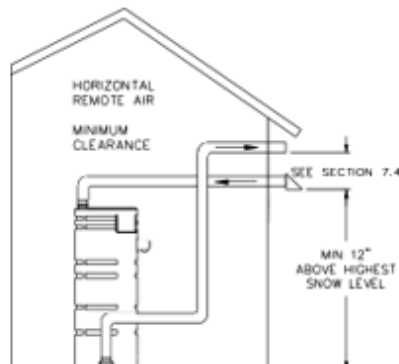

Combining Vents with a Draft Induc

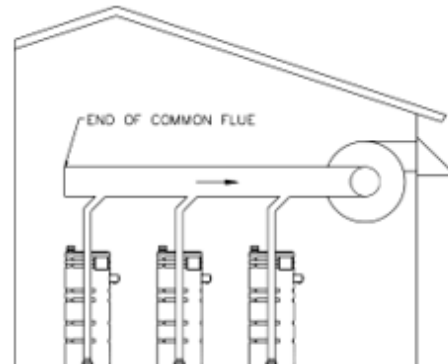

8.5 Optional Concentric Vent for Combustion Air and Exhausting Flue Products (Models 400 to 800)

To provide a single sidewall or roof penetration capable of both combustion air and flue exhaust termination, each Conquest water heater must be installed using an IPEX System Concentric Vent Termination Kit, which must be purchased separately. Both the IPEX System PVC and CPVC Flue Gas Venting Systems are third-party tested and listed to the appropriate standard. They comply with the non-metallic vent listing requirements in CSA B149.1 Natural Gas and Propane Installation Code.

The following IPEX System Concentric Vent Termination Kits are available through PVI for Conquest water heaters:

PVI Part No.	Description
122367	KIT, VENT CONCENTRIC 4 CPVC IPEX #197021 for CPVC (4" x 36")
150862	KIT, VENT CONCENTRIC 4 PVC IPEX #397713 for PVC (4" x 36")

Each IPEX System vent kit includes or specifies the required pipe, fittings, hardware, adhesives, and Installation instructions. Follow the IPEX Installation instructions and use only the materials and adhesives it specifies. Additional copies of the Installation Guide for the IPEX System concentric vent kit and additional information are available at www.ipexinc.com.

When using concentric vent termination kits, all combustion air ducts, all exhaust vent pipes, and the IPEX concentric vent kit material types must be the same. If the Conquest is installed with a PVC exhaust vent pipe, then the combustion air duct and the IPEX concentric vent kit must also be made of PVC. If the Conquest is installed with a CPVC exhaust vent pipe, then the combustion air duct and the IPEX concentric vent kit must also be made of CPVC.

WARNING: Follow the Installation instructions, termination requirements, and, if applicable, multiple concentric vent kit spacing requirements provided with the listed IPEX Concentric Vent Kit. Also, you must use only the pipe, fittings, and cement included or specified in the IPEX installation instructions. Failure to follow the IPEX installation instructions or to use pipe, fittings, or cement not included or specified in the IPEX installation instructions could result in an unreliable vent assembly or installation that can cause the potential for hazardous products of combustion to enter occupied areas and can cause property damage, exposure to hazardous materials, personal injury, or death.

The following information describes the components of the IPEX System Concentric Vent Termination Kit:

Item No.	Description
1.	Wye-(Concentric)
2.	Rain Cap
3.	Exhaust Vent Pipe (Inner)
4.	Fresh Air Intake Pipe (Outer)
5.	Stainless Steel Screw & Nut

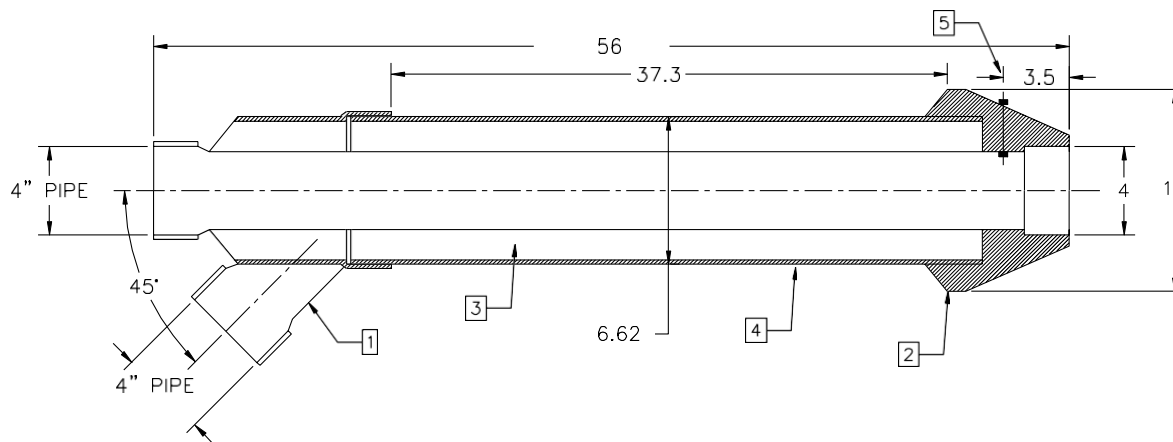

Concentric Vent Connections to the Vent pipe and Remote Air Inlet Duct

1. Only Conquest models 400 through 800 can obtain combustion air and exhaust products of combustion through a 4" exhaust IPEX System Concentric Vent Termination Kit. This option is not currently available for models 900 – 1200.
2. Do not exceed the maximum allowed combustion air duct and vent pipe equivalent lengths provided in the Combustion and Ventilation Air and the Venting sections of this Installation & Maintenance Manual. Remember to include the IPEX System Concentric Vent Termination Kit in the maximum equivalent calculation. When calculating the additional length added by the IPEX kit, use the diameter of the IPEX kit combustion air duct connection as the combustion air duct diameter.
3. Select a concentric vent kit that matches the material type of the Conquest flue gas pipe as described in the Section titled "Optional Concentric Vent for Combustion Air and Exhausting Flue Products." Six-inch Conquest venting can be used with a 4" IPEX concentric vent kit.
4. When using an IPEX System Concentric Vent Termination Kit connected to a 6" PVC or CPVC vent and remote air duct, use locally available fittings of the same material as the Kit to reduce from 6" to 4" immediately before connecting to a 4" IPEX Concentric Vent Termination Kit. The reduction from 6" to 4" does not change the maximum allowed equivalent vent length or the maximum number of elbows for a 6" pipe.

8.6 Polypropylene Venting and Low-Profile Terminations

For installations for which polypropylene venting and/or a low-profile vent termination are needed, any vent system tested and listed to UL-1738 and ULC-S636 for sustained flue gases up to 230°F (110°C) is acceptable. When a low-profile vent termination is needed, Centrotherm offers a 6" Low-Profile Termination Kit (model name ISLPT0606) suitable for the Conquest product lines. Consult with vent manufacturers for additional information.

WARNING: Follow the Installation instructions and termination requirements provided by the manufacturer of the listed (UL-1738 and ULC-S636) vent system. Also, use only the pipe, fittings, and cement included or specified in the manufacturer's installation instructions. Failure to follow the manufacturer installation instructions or to use pipe, fittings, or cement not included or specified in the manufacturer installation instructions could result in an unreliable vent assembly or installation that can cause the potential for hazardous products of combustion to enter occupied areas and cause property damage, exposure to hazardous materials, personal injury, or death.

8.7 Connecting to an Existing Vent System

Do not connect the Conquest to an existing vent system, until it has been confirmed the existing vent system complies with all requirements for a new vent system. A venting system in full compliance with the instructions provided in this manual is required for the safe and reliable operation of the Conquest. Do not connect the Conquest to a masonry chimney.

WARNING: Before operating the appliance connected to an existing vent system, confirm the vent system complies with all guidance and requirements for a new vent system specified in this manual. Failure to confirm the existing vent system complies can result in unsafe operation and the potential for poisonous carbon monoxide to enter occupied areas and can cause property damage, personal injury, exposure to hazardous materials or death.

SECTION 9: OPERATING AND SAFETY CONTROLS

9.1 Temperature and Pressure Relief Valve(s)

The tank is equipped with a temperature and Pressure Relief Valve(s) sized according to the ASME Boiler and Pressure Vessel Code, Section IV HLW.

WARNING: Secure the relief valve discharge pipe to a suitable floor drain so that very hot water does not openly splash during a significant relief valve discharge. If the relief valve discharge pipe is not routed and secured to a suitable drain, hot water discharge can result in property damage, scalding, and personal injury or death.

- Follow the temperature and pressure relief valve manufacturer's instructions and all local, regional, and national codes applicable to temperature and pressure relief valve installation and piping, including directions on inspection and maintenance of the valve at specified intervals.
- The relief valve discharge pipe must not be smaller than the relief valve opening and must be secured to prevent it from lifting out of the drain under discharge pressure and must be routed to allow complete drainage of the valve and line.
- Do not plug the relief valve (s) or install a reducing coupling, valve, or other restriction in the relief valve(s) discharge line(s); this will eliminate the critical water temperature and pressure protection it provides.
- Thermal Expansion – A relief valve that periodically discharges may result from thermal expansion if the water heater is installed in a system closed by components, such as a backflow preventer or check valve in the cold-water supply. These systems must be provided with means to control expansion. Contact a water heater or plumbing professional to resolve this situation.

WARNING: Do not plug the relief valve(s), use discharge piping smaller than the relief valve opening, or install a reducing coupling, valve, or other restriction in the relief valve discharge line. Failure to comply with these relief valve and discharge piping requirements can prevent the relief valve from providing its intended temperature and pressure protection, which can result in a sudden loss of pressure containment that can cause property damage, exposure to hazardous materials, personal injury, or death.

9.2 Cathodic Protection

PVI water heaters do not utilize cathodic protection. However, in hot water systems that do, hydrogen gas can be produced when the hot water system has not been used for a long period of time (generally two weeks or more). Hydrogen gas is extremely flammable. To prevent the possibility of injury under these conditions, one of the hot water system faucets should be opened for several minutes before using any electrical device connected to the hot water system. If hydrogen is present, there will be an unusual sound, such as air escaping through the pipe as the hot water begins to flow. Do not smoke, have open flames, or turn electrical switches on or off near the faucet at the time it is open.

9.3 Electronic Low Water Cut-Off

When the water level is above the electrode position in the tank, the reset pushbutton will energize the control (LED will be lit). The control remains energized until the water level drops below the electrode position (LED will not be lit). Unless otherwise specified, there is a three-second time delay on decreasing level. The water level must be below the tank probe location for a full three seconds before the control de-energizes. In the event a low water condition occurs, a failure message will be displayed on the controller touchscreen. This failure lockout can be reset by pressing the LWCO RESET button located on the front control panel. Hold the reset button in for 30 seconds to ensure a proper reset. The heater will operate when LWCO is cleared; an EOS reset is not required.

The Electronic Low Water Cut-Off probe is located in the top head of the water heater.

WARNING: Turn off all electrical service to the appliance when accessing the limit or other controls located inside the control cabinet or inside the burner vestibule inside the top of the appliance. Close and fasten the control cabinet and burner vestibule cover before restoring electrical service to the appliance. The cabinet and burner vestibule contain high-voltage wiring and terminals. If the electrical service is not turned off and these terminals are touched, a dangerous shock causing property damage, personal injury, or death could occur.

9.4 Operating Temperature Control

The front control panel houses an adjustable digital operating control, which is factory pre-set at approximately 120°F. For more information, see the Electronic Operating System section in this manual.

Le thermostat est réglé à environ 49 degrés Celsius. Températures de l'eau supérieures à 52 degrés Celsius peut causer instantanément de graves brûlures ou la mort de brûlures. Suivez les instructions dans le manuel d'installation pour modifier la température de l'eau.

9.5 High Water Temperature Limit

The Electronic Operating Control System (EOS) includes a single probe that contains the limit and the operating sensor. Since both these sensors are in the same location in the heated storage tank, the EOS checks to be sure their output is within a degree or two of each other. If not, or if the maximum water temperature exceeds 200°F, the EOS will lockout, and the manual reset button on the control panel must be pressed before the heater will resume operation.

SECTION 10: ELECTRONIC OPERATING SYSTEM (EOS)

The Conquest EOS consists of three components: the Platform Ignition Module (PIM), the plug-in ID card, and the Control Display. The PIM is connected to the control display using an RJ485 patch cable. This cable provides all communication between the PIM and the control display also provides power to the control display.

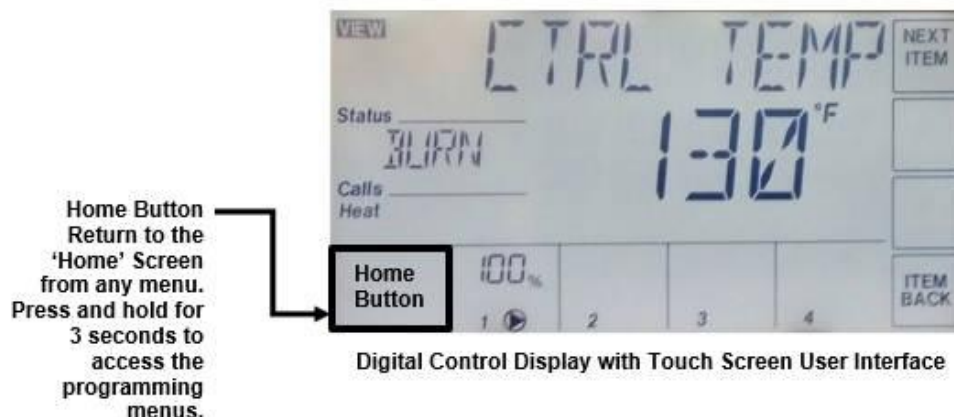
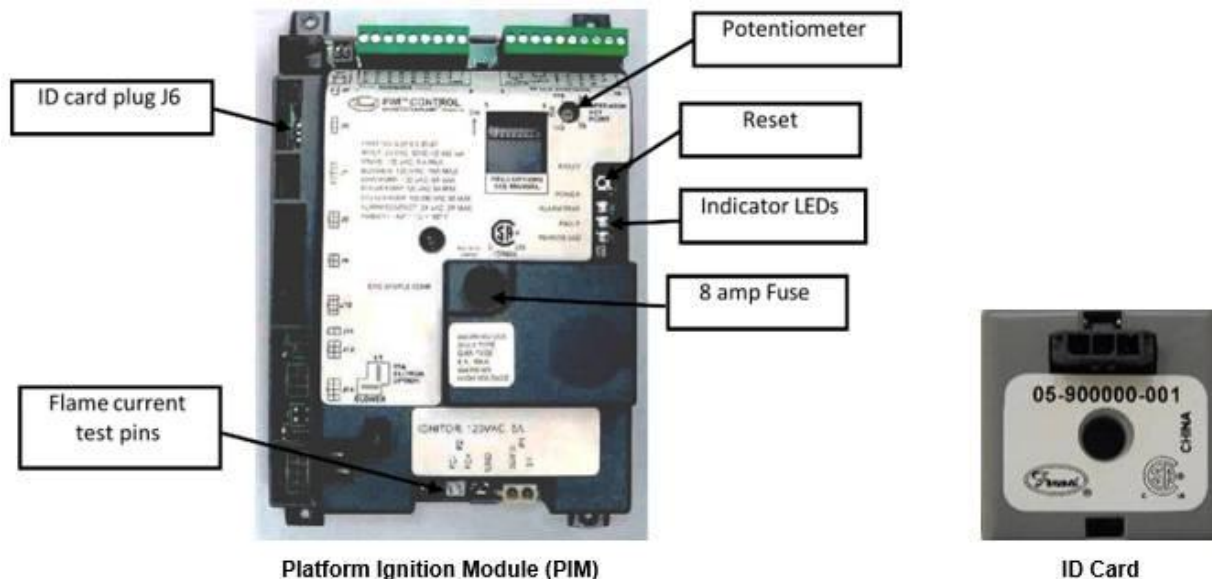

10.1 Touch Screen User Interface

The EOS touchscreen provides one-touch access to view and adjust various Menu set points. It displays Status Fields, Items, Heater Output, and Number Fields. It also contains buttons for navigation and adjustment and the Home Button to access menu selections.

10.2 Status Field Display

The Status Field displays the current operating status of the control display. Most items in the status field are only visible when in the VIEW Menu or an alarm condition is present.

Item	Description
SANI	Sanitation Mode is active. It momentarily energizes a field-installed sanitation pump and operates the heater at an elevated set-point temperature.
HAND	Hand Mode has been activated in the OVERRIDE Menu. This function allows the user to manually control the operation and firing rate of the burner.
OFF	The Off mode indicates that the system has been disabled in the OVERRIDE Menu.
PURG	The Purge mode indicates that individual pumps have been activated in the OVERRIDE Menu.
IDLE	The EOS is Idle due to no demand for heat
ARSW	The EOS is attempting to purge but waiting for the air proving of the blower airflow
PREP	The EOS is Pre-Purging the burner system
IGN	The Hot Surface Igniter is hot, and the gas valve has opened to attempt burner ignition (4 seconds)
BURN	The Burner has ignited, and the flame has been sensed.
POST	The Call for Heat has ended, and the EOS is post-purging the burner system

10.3 Operational Sequence Field Display

The EOS displays the following burner sequence, ignition status, timings, temperatures, and values:

Item	Value	Description
SATISFIED	°F	No Call for Heat based on temperature sensed at the control sensor at the top of the tank
CALL FOR	READY	Initiated when the temperature sensed at the control sensor at the top of the tank is 5 degrees less than the setpoint temperature.
BLOWER	mm:ss	Displays the pre-purge time countdown until the igniter heat-up begins
IGNITION	mm:ss	Displays heat-up time until the gas valve opens
CURRENT	0 - 10.0 µA	Flame Current (µA)
CTRL TEMP	°F	Flame is established, and the temperature sensed at the control sensor at the top of the tank is displayed.
BLOWER	mm:ss	When the call for heat has ended, the post-purge time countdown is displayed.

10.4 View Menu (Home Screen - Default Display)

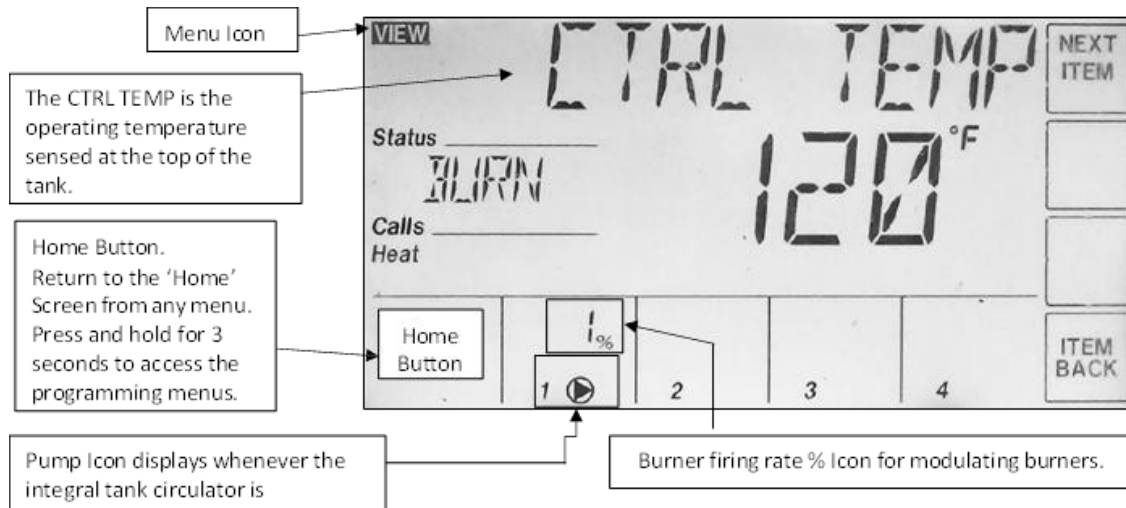

The **View Menu** is the EOS control system's default display (home screen). It displays general information about the water heater's operation and status. The default display includes a Burner Firing Rate % Icon for modulating units, a Pump Icon that is visible whenever the integral tank circulator is energized, and Failure Messages if the unit is in an alarm or error condition.

Use the **Next Item** and **Item Back** buttons to scroll and view the View Menu Item Fields and their associated values. The Item Field descriptions are listed below:

Item Field	Description
SETPOINT	The display screen displays the current operating set point but does not allow the user to make changes in this menu.
VENT	Displays the current flue gas temperature as measured by the flue gas sensor located in the flue outlet.
TANK TOP	It displays the current temperature at the top of the water heater tank as measured by the operating control sensor located near the hot outlet.
TANK BOT	It displays the current temperature near the water heater's mid-tank as measured by the control sensor responsible for regulating the operation of the integral tank circulator.
TANK ΔT	Displays the current temperature difference between the TANK TOP and the TANK BOT sensors.
FLAME CUR	Displays the burner flame current in approximate μA dc. Since this is an approximation, it is recommended that a flame current measurement be taken at the PIM control board using a micro-amp meter or digital multimeter at the FC+/FC- terminals 1VDC= 1 μA mp or 0.000001 Amp.
TIME	It displays the time of day. You can set the time in the TIME menu. It is visible if the clock is set and enabled.

10.5 Control System Menus

The control display has multiple access levels. System-critical settings will not be available for adjustment. The settings that can be adjusted by the user will display UP and DOWN adjustment arrows on the right side of the display screen. These programmable menu items are in the Control System Menu.

To access the Control System Menu:

1. Press and hold the HOME button for 3 seconds. The display will change to SETUP/MENU
2. Touch NEXT ITEM to navigate to the next menu. Touch ITEM BACK to go reverse.

3. Touch ENTER for user accessible menu item settings in the selected menus.
4. Most settings are in the USER access level. Another setting will be in the INSTALLER or ADVANCED access level, depending on the necessity for field adjustment. See Using the Toolbox Menu for details.

Control System Menu Descriptions

Menu	Description
SETUP	Displays and modifies the temperature control set points for the burner, integral tank circulator
SOURCE	Displays many factory-programmed settings for this product. The settings which can be adjusted by the user will be indicated by the appearance of the up and down adjustment arrows
MONITOR	Displays operational information such as water and vent temperatures, hours of operation, and number of cycles
TIME	Sets the time, day, and year. Setting the time clock is necessary when using the scheduled setback
SCHEDULE	Allows the user to create a schedule for reducing the water heater set point when a building is unoccupied for a period of time
NETWORK	This displays and modifies parameters for creating a Modbus communication connection with the water heater. Resetting the Defaults does not erase the settings in NETWORK.
OVERRIDE	Allows the user to assume manual control of the burner operation and pumps
TOOLBOX	Displays alarm message history. Changes User access level and reset to factory default settings

10.6 Changing the Vent Material Type (Advanced Level Access)

If the cold inlet water temperature is above 100°F, the use of solid CPVC, Polypropylene, or Stainless-Steel venting is required; the vent limit switch must be adjusted for the higher temperature rating allowed by these vent materials.

To Change the Vent Type Value:

1. From the View Menu, press and hold the HOME button for 3 seconds to enter the Control System Menu. The first menu displayed is the SETUP Menu.
2. Touch the Next Item or Item Back buttons to navigate to the TOOLBOX menu.
3. Touch the ENTER button to display the ACCESS screen.
4. Hold the #4 button to change to ADVANCED.
5. Exit the menu by pressing the HOME button.
6. Use the Next Item or Item Back buttons to navigate to the SOURCE menu.
7. Enter the SOURCE menu.
8. Use the Next Item or Item Back buttons to navigate to the VENT TYPE menu.
9. Using the UP or DOWN arrow buttons, select between the four choices: PVC (default setting), PPS, CPVC, or SS.
10. Exit the menu by pressing the HOME button.
11. Using NEXT ITEM or ITEM BACK, go to the TOOLBOX menu and press enter. Hold the #4 button to remove the ADVANCED level; use the arrows to return to the USER level. Hit HOME to exit the TOOLBOX menu and hit the HOME button again to exit the MENUS.

10.7 Changing The Operating Set Point (USER Level Access)

The water Conquest water heater operates to satisfy the stored water temperature set point of the EOS control. The value of the controls' set point is the desired stored tank water temperature. The unit ships with a factory set point of 120°F.

Although the set point can be displayed in the VIEW menu, it is necessary to enter the Control System Menu to adjust the water heater set point and other operational parameters.

To Change the Water Heater Set Point:

1. From the VIEW Menu, press and hold the HOME button for 3 seconds.
2. Touch the NEXT ITEM or ITEM BACK buttons to navigate to the SETUP menu.
3. Touch the ENTER button, then navigate to the SETPOINT using the NEXT ITEM button.
4. The new value will be saved when you navigate away using the NEXT ITEM, ITEM BACK, or HOME buttons.



10.8 Setting The Real Time Clock (User & Installer Level Access)

The TIME MENU allows the user to program the time of day, the date, and the year. Select 12- or 24-hour time clock as well as daylight saving time can be selected. When selected, the time clock can be displayed in the VIEW MENU.

1. Press and hold the HOME button for 3 seconds to enter the Control System Menu. Use the NEXT ITEM button to scroll to the TIME menu. Press the ENTER button to enter the TIME menu.
2. Use the NEXT ITEM button to move to the first screen. Use the UP & DOWN arrow buttons to set the hour, then press the NEXT ITEM button to enter the value and move to the minute. Once the parameters for the time screen have been entered, move to the date and year screen, and enter settings in the same manner.
3. Other features that can be configured: display clock in the VIEW MENU, enable daylight saving time, and 12/24-hour clock, use the NEXT ITEM button to move to the correct screen and then the arrow buttons to adjust. Save and exit the menu by pressing the Home button.



10.9 Scheduled Setback (USER Level Access)

The SCHEDULE MENU allows the user to program this water heater to automatically lower the operating set point when the facility is not occupied or hot water use is curtailed.

1. Press and hold the HOME button for 3 seconds to enter the Control System Menu. Use the NEXT ITEM button to scroll to the SCHEDULE MENU. Activate the schedule function by first turning on the HEAT SCHD using the arrow buttons.
2. There are four setback schedule types. 24hr, 5-2, 5-11 and 7DAY. The 24-hour schedule is a daily schedule that will follow the same program every day of the week. The default schedule on the SCHD TYPE screen is the 24hr. All other schedule types are selected using the arrow buttons. The 24-hour schedule allows for a 2 or a 4 EVENT/DAY. With the 2-event day, the user can have one occupied time and one unoccupied time per day. The 4-event day will allow for two occupied times and two unoccupied times per day.

NOTE: The unoccupied set points are programmed in the SETUP MENU in the same manner that the occupied set point is adjusted.

For example, a 24-hour type and a 4-event day schedule might look like this:

- a. The first occupied time begins at 6:00 a.m., and the first unoccupied time begins at 11:00 a.m. Therefore, between the hours of 6:00 a.m. and 11:00 a.m., the occupied set point will be used.
- b. The second occupied period begins at 4:00 pm, and the second unoccupied time begins at 10:00 pm.
- c. Between the first unoccupied time of 11:00 am and the beginning of the second occupied period, the unoccupied set point will be used.
- d. At 4:00 p.m., the second occupied period will begin, and the occupied set point will be used until the second unoccupied period begins at 10:00 p.m.
- e. From 10 pm until 6:00 am, the unoccupied set point will then be used.

Notice that schedule times and set points are identified as occupied (**Occ**) or unoccupied (**UnOcc**) here.

3. The 5-2 schedule type allows the user to program a 2 or 4 EVENT/DAY but also allows for one schedule to be followed Monday through Friday and then another Saturday and Sunday.
4. The 5-11 schedule type allows the user to program a 2 or 4 EVENT/DAY but also allows for one schedule to be followed Monday through Friday and then a separate schedule on Saturday and Sunday.
5. The 7-DAY schedule type allows the user to program a 2 or 4 EVENT/DAY for each day of the week, Monday through Sunday.



10.10 Using the Manual Override Menu (ADVANCED Level Access)

The OVERRIDE MENU is helpful during initial commissioning and anytime burner adjustment is necessary. Manual override allows control of the burner, integral tank circulator, and the optional SANI pump controls. When adjusting combustion in Manual Override, you will bypass the setpoint. Ensure you do not create a scalding situation and have enough hot water to complete combustion adjustments.

TO ACCESS THE MANUAL OVERRIDE MENU and ENTER THE ADVANCED LEVEL ACCESS:

1. Press and hold the Home button for 3 seconds to enter the menu selection.
2. Touch the Next Item or Item Back buttons to navigate to the TOOLBOX menu.
3. Touch the ENTER button to display the ACCESS screen.
4. Hold the #4 button to change to ADVANCED access level.
5. Exit the menu by pressing the HOME button.
6. Use the Next Item or Item Back buttons to navigate to the OVERRIDE menu.
7. Enter the OVERRIDE MENU. Using the arrow buttons, select between the three choices. The default setting is AUTO. In the AUTO position, the operating temperature control will work to control the water temperature based on the active set point. When manual control of the water heater operation is complete, always return this parameter to the AUTO setting.
8. The second setting is OFF. This setting will stop all control functions and prevent the burner from operating.
9. The third setting is HAND. Once enabled, use the NEXT ITEM button for the TIMEOUT setting. This is a safety precaution that will disable the override function at the end of the specified time if the MAN OVR setting is not returned to AUTO.
10. The next screen is SAN PUMP. To force on the SANI pump, turn this setting to ON. It is only used when the SANI option is present.
11. The next screen is HTR PUMP. To force on the integral tank circulator, turn this setting to ON.
12. The next screen is HTR MOD. This setting will override the operating control and using the up and down arrow buttons, force the burner to fire at the selected firing rate. This function is useful when tuning the operation of the burner at various firing rates.

NOTE: If the HTR MOD control is activated while the burner is firing, the burner will shut down and recycle.

WARNING: When adjustments are complete and before putting the water heater into service, return the MAN OVR function back to "AUTO" Failure to return the MAN OVR function to "AUTO" can cause high water temperatures that can result in property damage, scalding, other serious injury or death.



Potentiometer (Operating Set Point for Standalone Operation)

The PIM Ignition Control will continue to operate the Conquest water heater at a 120-degree internal setpoint should the touch screen control fail or communication between the two devices be interrupted. This internal setpoint can be adjusted using the potentiometer to maintain a different operating temperature under these circumstances if desired. This feature is intended to be used on a temporary basis since the accuracy of temperature control is dependent upon the touch screen control.

IMPORTANT: It is recommended that at the time of commissioning, the startup technician adjusts the potentiometer to the desired set point displayed in the OPERATOR screen located in the SOURCE control system menu. The standalone set point can be adjusted independently of the touchscreen, but a specific setting may be difficult to achieve using the temperature index on the PIM. (See POTENTIOMETER Adjusting the Setpoint.)



NOTE: If the operating setpoint is ever changed after initial commissioning, the potentiometer should be readjusted as well.

10.11 Using Toolbox Menu

The TOOLBOX MENU contains several adjustable parameters as well as up to the 15 past alarm messages logged.

1. The ACCESS level is in the Toolbox. The three choices available here are USER, INSTaller, and ADVANCED. USER and INSTaller can be accessed using the arrows. The ADVanced level can be selected/toggled by holding the #4 button. Consult the factory before changing any settings requiring an ADVanced access level. Depending on the access level selected, different parameters will become visible and adjustable. Selecting the appropriate access level will make menu navigation easier and minimize the possibility that parameters will be unintentionally changed, resulting in improper operation.
2. The SW screen will display the software revision for the touch panel display. Press the enter button to view the suffix.
3. Allows the user to turn the display backlight ON continuously, OFF, or TMPY will keep the backlight on only during use.
4. Allows the user to choose between Fahrenheit and Celsius.
5. The last screens will show the 15 most recent alarms. From the first screen, if you hit ITEM Back, you will see the oldest alarm and the item back to move to the next most recent. If the Real Time Clock has been set, the date and time will be logged for each alarm. The alarm history is only available at INSTALLER or ADVANCED user levels. While on the history, hold the CLR button for 3 seconds to clear that error message.

10.12 Basic Operational Reference Information

Ext Enable: Terminals R1 – R2, Jumper to enable. The heater ships with a jumper on this. An external enable/disable can be attached to this. You can monitor the state of this input. 1 = enabled.

Upper Tank Temp: This is a temperature probe at the top of the tank.

High Limit Temp: This is a second sensor in the same mechanical probe as the Upper Tank Temp probe. It is used as a safety measure.

Lower Tank Temp: This sensor measures the temperature of the mid-section of the tank and controls the integral tank circulator pump.

Vent Temp: Temperature of the Flue gasses exiting the heater.

Modulation: Represents the signal sent to the fan motor.

Pump Status: This is the integral circulating pump ON/OFF.

Pump Runtime: Hours on for integral circulating pump.

Discrete connections:

Enable/Disable: R1 – R2 (Input to heater) Closed = ENABLE. Alarm: A1 & A2 (Output from Heater) Closed = ALARM or ALERT.

Remote Equipment / Burner ON: P1 – P2 (Output from Heater) Closed – Heater is heating.

Remote Proving: C1 – C2 (Input to heater).

- Closed = Remote device is ready; it is OK to operate the burner.
- Open = Remote device is not ready. If the heater has a call for heat, this will cause an error if not resolved within a few minutes.

SECTION 11: SECTION 11: COMMUNICATIONS AND DIAGNOSTICS

11.1 Indicators

The PIM has three LED indicators to display the status and help diagnose system error conditions:

- Power: Green LED indicating the PIM module is receiving 24 VAC power.
- Alarm/Test: The Amber LED indicates that the PIM is in Commission Test Mode or that a diagnostic alarm (fault) is present.
- Diagnostic Code: This is a red LED that is normally off. During a control or system fault condition, it flashes the error codes.

11.2 Alarm Messages – Diagnostic Codes (Flashes)

MESSAGE	DESCRIPTION OF ALARM	LED Flashes
ID CARD	When the system is initialized for the first time, the ID card is connected to the PIM control board and selects the control profile to be used. An ID card error may occur when the original card is replaced with an incorrect card or has been disconnected from the PIM control board.	Red LED ON, Green LED OFF
INTERNAL FAIL	The PIM control board may have failed. If manually resetting the control does not correct the fault, replace it.	Red LED ON
CTL SETUP FAIL	Try resetting the defaults in the TOOLBOX menu. If unable to correct, replace the control display	N/A
VENT LIM	The vent temperature sensor is approaching the programmed limit, which will force the burner to operate at a reduced firing rate to prevent overheating.	N/A
AIR FLOW FAIL	During purge and burner operation, the blower speed tachometer does not reach the minimum blower speed for operations. This could be caused by a faulty blower.	1
FLAME FLSE	A false flame signal is usually caused by a leaky gas valve that propagates a flame after the call for the heat cycle has ended. Check for leakage through the gas valve. If no mechanical cause can be found, replace flame control.	2
FLAME FAIL	Flame failure indicates that during the burner ignition process, the burner either failed to light or it did light, but no flame signal was detected. If the burner fails to light, it is likely that the hot surface igniter (HSI) is faulty or the burner fuel/air mixture is too far out of adjustment to ignite. If the burner lights but immediately goes out, check for an inadequate gas supply, faulty gas valve or regulator, or poorly adjusted combustion.	3
FLAME LOSS	Flame loss indicates that sometime after the flame has been established and the burner is operating, the flame signal is lost. A faulty igniter can cause this, damaged refractory or combustion that becomes poorly adjusted as the burner modulates to higher inputs.	3
LOW HSI	The PIM control board is not sensing the correct amp draw from the HSI (Hot Surface Igniter). This is most likely caused by a faulty or disconnected igniter.	4
LOW 24VAC	The 24VAC supply to the PIM control is below the threshold for reliable control operation. This may be caused by low voltage to the heater or a faulty 120/24VAC supply transformer.	5
VENT MAX	The vent temperature sensor is used to protect low-temperature vent systems from damage caused by high flue gas temperatures. When this alarm occurs, first confirm that the vent material is suitable for the application as well as the limit setting for this control. When this product is operated with high return or inlet water temperature, the flue gas can exceed the rating of low-temperature vent systems.	6
HTR MAX	The heater's high-limit temperature safety has exceeded its limit. This condition may be caused by a sensor failure or a faulty control board.	7

MESSAGE	DESCRIPTION OF ALARM	LED Flashes
HTR TOP	Indicates a problem with the top temperature sensor, possibly a broken or shorted sensor wire or failed sensor. NOTE: The top sensor and the high limit sensor or located in the same probe body.	8
HI LIMIT	Indicates a problem with the high limit temperature sensor, possibly a broken or shorted sensor wire or failed sensor. NOTE: The top sensor and the high-limit sensor is in the same probe body.	8
HTR BOT	Indicates a problem with the bottom temperature sensor, possibly a broken or shorted sensor wire or failed sensor.	8
VENT	This indicates a problem with the vent temperature sensor, possibly a broken or shorted sensor wire or failed sensor.	8
LOGASPRES FAIL	The low gas pressure safety switch (optional) does not sense the minimum gas pressure required for safe burner operation. Check the gas pressure to ensure that the minimum is available. If the gas pressure is adequate, check for fluctuating gas pressure or a faulty pressure switch.	9
REM PROV FAIL	The remote proving circuit, when used, is designed to check for the operation of ancillary mechanical room equipment such as a fresh air damper or flow switch. Check for the proper function and correct wiring of such equipment.	10
LOW WATER FAIL	The electronic low water cutoff is no longer sensing water at its probe. This could also be caused by a faulty low water board or sensor	12
HTR LOST	This could be caused by a poor connection between the PIM control and the digital control display or failure of either device.	14
HIGASPRES	Check the gas pressure to ensure that the building supply doesn't exceed the value on the heater rating plate. If the gas pressure is within the rated limit, check for a faulty pressure switch.	15

11.3 Replacing the Fuse

The 24 VAC input and output circuits of the PIM are protected by an 8.0 Amp fuse.

11.4 Self-Check/Control Failure

The PIM confirms the integrity of the gas valve relay contacts to ensure safety. It also monitors the processor memory and software execution for proper program flow. If the control detects an error in its software or hardware, all outputs are turned off, and the LED displays a steady ON condition. If this condition persists after an attempt to restart, then the control must be replaced.

11.5 System Safety Checks

The PIM monitors the safety switches, temperature sensors, supply voltage, and blower speed and will go to soft lockout until the error condition is corrected. Individual LED diagnostic codes or messages on the RS485 communications help identify the problem for efficient troubleshooting.

11.6 Flame Current Measurements

The PIM supports direct measurement of flame signal strength using the flame current test pins (FC+, FC—) on connector P2. Flame current may be measured by a micro amp meter (μ A meter) or a standard digital voltmeter. The signal on P2 is calibrated to 1 micro-amp/volt, so flame current in micro-amps can be directly read on the volts scale.

The control display user interface can display an approximation of flame current up to 5 micro-amps.

11.7 Non-Volatile Lockout/Manual Reset

The PIM normally allows for a volatile ignition lockout where a lockout condition is reset by a loss in 24VAC power or the call for heat demand. In certain applications or where required by standards (such as CSD-1), it can be configured through the parameter settings for non-volatile lockout after ignition failure. In this case, the lockout may only be reset by the on-board manual reset button or the remote reset on the front panel. Additionally, the PIM is programmed to allow three tries for ignition before lockout occurs. After the lockout, if there has been no intervention to reset the lockout after fifteen minutes, the control will automatically reset the lockout count and retry for ignition.

11.8 ID Card

The PIM determines its operating parameters by reading the identification code of an external plug-in ID card, which is connected to the PIM at the J6 connector.

NOTE: This ID card must be present for the PIM and appliance to operate. This card selects the proper settings in the PIM's memory for various appliance models. The first time a PIM is powered up and attached to an ID card, the ID card setting is stored in non-volatile memory. Once set, the PIM only operates with the correct ID card installed that matches its internal ID settings. The PIM verifies the ID card at power-up and on each heating cycle.

SECTION 12: NETWORK MENU

The Network Menu contains all the settings necessary to configure a 2-wire RS-485 communication link with this product. With no additional hardware, a Modbus RTU or BACNET MSTP protocol can be established. For a complete Interface Guide and Points List (PV7213) go to www.pvi.com and look in the documentation and tools page under the Accessories and Controls tab.

SECTION 13: REMOTE CONNECTIONS – TERMINAL STRIP

13.1 BMS/BAS Remote Connections for Analog and Binary Signals

A terminal strip for the remote connection is located behind the bottom control panel door and is accessed by removing the two thumb screws a lifting the hinged door.

IMPORTANT: Do not use single-strand bell wire for remote field connections to terminals R1-R2 and C1-C2. Use only multi-strand copper wire. See the table below for wire length and gauge:

Wire Gauge	18 GA	16GA	14 GA	12 GA
Maximum Length	30 FT	50 FT	75 FT	100 FT

WARNING: Turn off all electrical service to the appliance when accessing remote connections and close and fasten the control cabinet cover before restoring electrical service to the appliance. The remote connection terminals are High-Voltage or may become High-Voltage. If the electrical service is not turned off and these terminals are touched, a dangerous shock could occur, causing personal injury or death.

Coupez l'alimentation avant intervention sur l'appareil.

13.2 Terminal Functions

L1-L2: Used for incoming 120VAC power supply connection.

Terminal L1 is the hot terminal (Black), and L2 is neutral (White). For the circuit ampacity rating, see the product label or specification document.

R1-R2: This is used to activate/deactivate the water heater from the remote master control. When switching this low-current circuit, a relay with gold-plated contacts or two relay contacts in parallel must be used. Terminals are wired to a relay in a remote Energy Management System. When the relay closes, the circuit from R1 to R2 is completed, and appliance controls are enabled. This appliance ships from the factory with a jumper between terminals. Remove the jumper when connecting to a remote controller.

A1-A2: Used to activate a remote alarm, signaling shutdown of combustion control. Alarm or Alert: this will be made up on hard lockout and non-hard-lockout conditions until the condition is gone, for example, remote proving not made up.

This provides a maximum 2 amp 0-30VAC relay contact closure when the control system terminates operation due to a tripped safety interlock (air proving switch, high limit switch, flame sensor, etc.).

P1-P2: Provides a 5 amp 120/240VAC contact closure to control remote equipment (i.e., mechanical room air louvers, draft inducer, or power vent, etc.). Do not directly energize pumps or motors through these terminals. If the operation of remote equipment is required for the safe operation of the appliance, the remote equipment must send a return proving signal to terminals C1-C2 via its proving switch, confirming proper operation to enable the appliance to start heating.

C1-C2: Used for proving the operation of a remote device. Terminals are wired to a proving switch on a remote device such as a power vent, louvers, or a combination of these in series. When all remote proving switches close, the circuit from C1 to C2 is completed, and the appliance controls are enabled. This appliance ships from the factory with a jumper between terminals C1 and C2 that must be removed when a proving switch is connected.

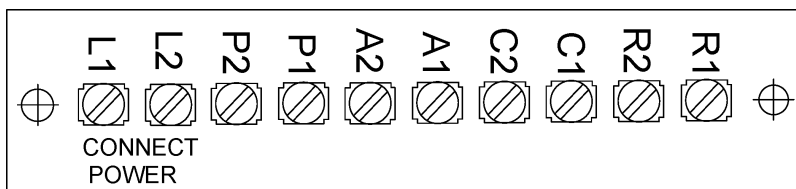

SECTION 14: SEQUENCE OF OPERATION

1. Incoming 120VAC
 - a. Full-time power to the Main Control Switch
2. **Power On** – When the main control switch is turned on:
 - a. 120V to PIM J14 for blower circuit
 - b. 120V to the fuse
 - c. Fused 120V is applied to the step-down transformer (24V)
 - d. Fused 120V is applied to the L.W.C.O. terminal L1.
 - e. 24V and Fused 120V are applied to the Platform Ignition Module (PIM). The circulator and HSI circuits are 120V.
 - f. The PIM performs a processor and memory self-test to ensure proper operation. The PIM confirms the presence of a valid ID card that matches the configuration previously stored in memory. If the valid ID card is not present, the PIM generates a diagnostic fault. The non-volatile memory is checked for an active hard lockout condition. A lockout indicates the previous attempt to light was unsuccessful, such as a hi-limit or other system fault occurred. The PIM stays in hard lockout until a manual reset is performed. After the lockout, if there has been no intervention to reset the lockout after fifteen minutes, the control will automatically reset the lockout count and retry for ignition.
3. **Control Device Pre-check**—The following control circuits are checked for closer before the control system initiates a Call for Heat.
 - a. The PIM continuously monitors the flame status to verify no flame is present during Standby. If an erroneous flame is detected, the PIM generates a false flame fault.
 - b. The Electronic Low Water Cut-Off control is a self-contained electronic device that senses the presence of water at the top of the storage tank. When the presence of water is confirmed, the contacts close on the ELWCO, which is sensed by PIM control. A solid red LED on the LWCO PCD indicates the presence of water.
 - c. The High-Temperature Limit is combined in a common probe body with the upper tank sensor. The PIM will compare the high-limit thermistor temperature with the upper tank thermistor temperature. If the two temperatures are not the same, a sensor failure will result.
 - d. When the High-Temperature Limit operation has been verified by comparison, the limit temperature will then be confirmed to be under the maximum allowable temperature.
 - e. The enable circuit between Terminals R1 – R2 must be closed for the heater to start operation. If no external enable, the terminals should be jumped. (Factory default)
4. **Call For Heat** – If the operating control senses that the temperature at the upper tank sensor is below the heater set point less heater differential and the previous control interlocks and safeties are satisfied, the following sequence will begin:
 - a. Terminals P1-P2 are closed to activate any connected remote devices.
 - b. Any connected remote proving switches close the circuit between Terminals C1-C2, enabling the water heater to continue the sequence of operation.
 - c. Gas pressure switches are latching. If proper gas pressure is present, the contacts will be made up. If the gas switches are tripped, they will rewire and reset manually when proper gas pressure is present.
 - d. When the burner blower is energized, and operation is verified by the blower motor TAC signal to prove flow.
 - e. The ignition pre-purge delay takes place. Approximately 15 seconds.

- f. The voltage level of the 24 VAC supply input is confirmed to be above 18.0 VAC.
 - g. The Ignition cycle begins.
5. **Heat-Up** – Following the pre-purge delay, the hot surface igniter will be energized:
 - a. The flame control will send 120V to the hot surface igniter for approximately 20 seconds heat up time.
 - b. The HSI Element proving current is verified.
 - c. The heat-up delay takes place to allow the hot surface element to reach ignition temperature.
6. **Ignition** – When heat-up time is completed, a 4-second Trial for Ignition (TFI) period is initiated:
 - a. Gas Safety Valves are energized. (Opened) allowing gas to flow.
 - b. The hot surface element is de-energized during the last second of the TFI period.
 - c. During TFI, the flame safeguard control will monitor the flame using flame rectification through the hot surface igniter and flame rod on some models.
 - d. If the flame control senses the presence of flame before the end of the TFI period, it will continue to monitor the flame through the igniter and flame rod until the operating thermostat ends the call for heat condition.
7. **Heating**
 - a. The flame status, LWCO switch, and other safety switches are continually monitored for proper state.
 - b. The High Limit sensor is confirmed to read below the High Limit set-point.
 - c. The tank's water temperature is compared to the temperature control set point to determine when to begin firing in heating mode.
 - d. The water heater remains in heating mode, and with extended operation, condensation begins to fill the condensation trap and drain line; (a normally operating booster heater does not create condensation). The water heater stops firing when the tank water temperature matches the temperature control set point.
 - e. The gas valve(s) are immediately disabled.
 - f. A Blower Post-purge is completed, and the control proceeds to Standby mode.
8. **Integral Circulating Pump** – The circulating pump is controlled independently of the call-for-heat.
 - a. When the main control switch is turned on, the control system continuously monitors the tank's water temperature and attempts to maintain a uniform temperature by using the integral circulating pump.
 - b. Under the default settings, when the temperature sensed in the tank drops 5 degrees or more below the temperature set point, the pump is energized, and a pump circulator icon illuminates on the control display touch screen.
 - c. The operation of the integral circulating pump may occur before, during, or after the call-for-heat period.
 - d. The pump's setpoint is by default dependent (DIP) on the heater's setpoint, but the control can be configured for a specific pump setpoint, the PUMP SETPOINT parameter.
9. **Flame Failure / Flame Loss**
 - a. If the igniter fails to sense flame during an attempt to light the burner (Ignition Trail Fail), the ignition control will end the ignition sequence, and the gas valve will be closed. Immediately following the end of the first failed ignition cycle, a new ignition sequence will be initiated to attempt to relight the burner. The standard configuration of the Conquest water heater allows for three ignition failures before

lockout. This ignition failure will result in a lockout and require a manual reset to attempt operation again. After the lockout, if there has been no intervention to reset the lockout after fifteen minutes, the control will automatically reset the lockout count and retry for ignition.

- b. If the burner successfully lights and operates but the flame is lost, the gas valve will be closed, and the blower will continue to operate to purge any remaining combustion products from the water heater. The standard configuration of the Conquest water heater allows for three (Main Flame Loss) occurrences before lockout. Following each (Main Flame Loss), the PIM will purge and initiate the ignition sequence. If the Conquest fails to light in the following 2 attempts, the error will be logged as a Main Flame Loss. After the lockout, if there has been no intervention to reset the lockout after fifteen minutes, the control will automatically reset the lockout count and retry for ignition.

SECTION 15: INITIAL STARTUP

15.1 Initial Startup Requirements

Installation must be complete prior to performing initial startup; and the startup must be complete prior to placing the water heater into service. Starting the water heater without proper piping, combustion air, venting electrical connections, or control settings can be dangerous and may void the product warranty. The following startup instructions must be followed precisely to achieve proper and efficient operation to ensure trouble-free service life.

WARNING: Proper startup must be made by a qualified installer or service agency, who must read and follow the supplied instructions and appliance markings. Failure to complete proper startup before use, tampering with controls, or not following all instructions and markings may damage this equipment, void the warranty, and result in property damage, personal injury, or death.

15.2 Tools and Instrumentation Required

- Electronic Combustion Analyzer with stack temperature and draft gauge
- Two-digit or U-tube Manometers or pressure gauges
- Multi Meter VAC, VDC, Ohms, Continuity
- Amp Meter Clamp on recommended
- Normal Hand Tools

15.3 Resources

- Product Installation & Maintenance Manuals
- Start-up Report with instructions
- Local, State, & Federal Codes
- Website: www.pvi.com
- Technical Support: 1-800-433-5654

15.4 On-Site Considerations

- Electrical Supply in accordance with the Nameplate Rating
- Adequate uncontaminated indoor or outdoor combustion air
- Adequate Fuel Supply
- Adequate Water Supply
- Exhaust Vent that complies with the installation instructions
- Condensate drainage that complies with the installation instructions
- Enough heat rejection (usage) to allow the heater to complete combustion analysis

15.5 Pre-Startup Checklist

Before starting the unit, check for adequate electrical service, confirm if any external control wiring connections exist, confirm the tank is filled with water, check all tank connections for leaks, and ensure the condensate trap is installed properly and that the gas supply meets the product rating decal requirements as follows:

CHECK ELECTRICAL SERVICE:

1. Start by checking the electrical service. The standard electrical service required is a 120-volt, single-phase, 60 Hertz power supply that is also electrically grounded. For the electrical service requirements for your specific product, see the appliance rating decal on the front of the unit.
2. Shut off the electrical service to the unit and turn the water heater power switch to the OFF position.
3. Remove the panel screws to lower the hinged upper control enclosure panel.
 - a. Locate the document packet containing the wiring diagram.

- b. Remove the fuse cap from the front panel and check for the installed fuse.
 - c. Check the back of the digital control display board on the hinged panel to see if a 2-wire RS-485 communication cable is connected. These wires must be removed to isolate the water heater from the Building Automation System during startup. Remember to reconnect the communication cable to the digital control display board after the startup is complete.
 - d. Check that all components are intact, and no damage has occurred during installation.
 - e. Also check to ensure all wire connections within the control cabinet are tight. A loose connection could cause sporadic shutdowns and malfunctions.
 - f. Close the hinged upper control enclosure panel and secure the panel screws.
4. Now remove the panel screws on the hinged bottom control enclosure panel.
 - a. Check to see if terminals R1 and R2 are jumped. If they are, nothing more needs to be done. If the terminals are not jumped but have wires connected to them, this indicates that a remote on/off relay is controlling the water heater from the Building Automation System. These wires must be removed prior to startup, and the terminals must be jumped. Ensure it is safe to operate the heater with this enable/disable bypass. Remember to remove the jumper and reconnect the remote controlling wires after the startup is complete.
 - b. Once again, visually check to ensure that all components are intact in this area and that all wire connections are tight.
 - c. Now close the hinged bottom control enclosure cover and secure the panel screws.

CONFIRM THE TANK IS COMPLETELY FILLED WITH WATER

For Conquest models applied as a Booster Water Heater:

When filling a Conquest applied as a booster water heater, the fill water supplied by the general-purpose water heater should be a minimum of 140°F. If colder water enters the booster heater inlet during startup or at other times, condensation may occur and may cause a burner lockout. To remove this startup condensation, after startup is complete and the booster heater storage tank has reached its intended maximum water temperature, turn the booster heater off, remove the condensation drain plug, allow any condensation to drain, replace the drain plug and turn the booster water heater on.

IMPORTANT: Venting the tank using the T&P Relief valve alone will not allow it to fill completely!

1. Close the drain valve.
2. Fully open the shutoff valves on the cold-water inlet and hot-water outlet piping to the unit.
3. Open the T&P valve to vent the tank. Close the valve when the flow is observed.
4. Open a nearby hot water faucet(s) to allow trapped air to escape from the piping.
5. A steady flow observed from the hot water faucet(s) indicates that the tank is full.
6. Close the hot water faucet(s).

CHECK TANK FLANGES AND PLUMBING CONNECTIONS FOR LEAKS

Be sure all connections into the tank are tight, as leaks at tank fittings will damage the insulation.

CHECK THE CONDENSATE TRAP

A condensate trap assembly ships with the unit and must be installed on the condensate drain to prevent flue gasses from escaping and creating a hazardous condition in the installed space. The condensate drain is located at the bottom rear of the water heater near the flue outlet.

Connect the condensate trap assembly to the PVC fitting on the condensate drainpipe. Then rotate the trap so that it contacts the floor. Connect 1/2" ID clear vinyl tubing, rated for 170 degrees or higher, or an optional Condensate Neutralization System to the barbed hose connection at the end of the primed condensate trap.

The condensate trap must be primed before the unit's initial startup. Priming a unit means adding water to the trap.

CONFIRM THE GAS TYPE

Confirm that the gas type supplied matches the rating label requirement on the front of the water heater. The Conquest water heater requires either Natural or Propane gas. If the available gas type is not correct, your unit will require a conversion. Contact the factory for instructions for converting to or from Natural or Propane Gas.

CONFIRM THE SUPPLY GAS PRESSURE

WARNING: If you smell gas, Do not try to light any appliance, touch any electrical switch, or use a phone in your building. Immediately call your gas supplier and follow their instructions.

For **Natural Gas**, the maximum inlet static gas pressure must not exceed 14.0 inches of water column and must not drop below 3.5 inches of water column during operation.

For **Propane Gas**, the maximum inlet static gas pressure must not exceed 13.0 inches of water column and must not drop below 8.0 inches of water column during operation.

To check the supply gas pressure:

1. First, shut off the main gas supply to the water heater. Never check the gas pressure without first completing this shut-off step.
2. Remove the cover plate at the top of the water heater to access the burner and gas train.
3. Ensure both manual gas valves at the burner and at the inlet of the gas train are closed.
4. Close the inlet gas valve and the valve before the fan. Attach a 1/8" NPT pilot shutoff test valve and tube to the test port on the manual shutoff gas valve at the inlet of the gas train.
5. Attach manometers or gas pressure gauges to the inlet gas pressure tube.
6. Open the main gas supply to the water heater and check for gas leaks on all joints upstream of the manual shutoff gas valve at the inlet of the gas train.
7. Now measure the supply gas pressure.
8. **IMPORTANT:** If the supply gas pressure is outside of the allowable range, notify the building maintenance personnel or installer to reduce the gas pressure to the water heater.
9. Now open the manual gas shutoff valve at the inlet of the gas train and check the gas train for leaks using a soap solution. If any bubbles are detected, close the manual gas valve, tighten the leaking connection, then open the manual gas shutoff valve again and check for leaks.
10. After the leaking valve is replaced, the gas train must be leak-tested again before starting up is attempted.
11. The burner uses a hot surface igniter (HSI) as the ignition source. Connect a test meter to the ignition control to read the flame current in micro amps. The PIM module has terminals FC+ & FC-. Connect a micro amp meter to the terminals, or you can use a digital voltmeter. 1VDC = 1 μ Amp or 0.000001 Amp

15.6 Startup Procedure

1. Begin by turning the Conquest power switch to the OFF position. Some venting systems have a test port section or option. If the vent system does not have a test port, you will need to drill a small test hole in the flue vent approximately two feet from the vent connection. Insert the combustion analyzer probe into the vent test hole.
2. Simulate a Safety Shutoff Ignition Fail Test of the EOS control system:
 - a. With the manual gas valve at the burner closed, turn on the electrical service to the water heater, and then turn the Conquest power switch to the ON position.
 - b. The EOS Temperature control touch screen will energize. If the tank temperature is 5 degrees or more below the factory set-point of 120 degrees, the Call-For-Heat sequence will initiate.
 - c. With no gas pressure, the ignition control will attempt to ignite the burner three times before proceeding to a safety shutoff. Following the third failed attempt, the display screen will immediately show that a LOCKOUT condition has occurred.
 - d. In a few seconds, an ERROR code will flash in the Status field, and a FLAME FAIL alarm message will be displayed. This will be followed by the troubleshooting message "IGNITION TRIAL FAIL," which will scroll across the top of the screen.
 - e. **IMPORTANT:** Before restarting the unit, ensure there is a way for the system to dissipate heat. This can be accomplished by opening one or more nearby hot water faucets.
3. Open the manual gas shutoff valve at the burner, then press and release the MAIN RESET button on the front panel of the water heater to recover from the lockout condition. If all control interlocks and safeties are satisfied, the control will automatically reset and attempt to start a new heating cycle. When the Call-For-Heat sequence begins, the burner/blower will energize. The status field of the display screen will show that the airflow is waiting to be proved by the TAC signal.
 - a. Once the blower operation is proven, the Ignition Pre-Purge sequence and the Hot Surface Igniter heat-up Period will begin. During this pre-purge period, the BLOWER message will be displayed.
 - b. Following a pre-purge and Hot Surface Igniter Heat Up countdown of about 36 seconds, a 4-second trial for the Ignition period will be initiated. During this sequence, the screen will display **IGNITION** while the gas valves are being energized.
 - c. Once ignition occurs and the flame is proven, the Status field will show that the **BURNER** is firing, and flame **CURRENT** will be displayed in microamps for about 8 seconds.
 - d. As the burner fires, the modulating firing rate percentage at the bottom of the screen will increase and decrease as the unit reaches its set point temperature of 120 degrees.
 - e. The **CONTROL TEMPERATURE** sensed at the top of the tank will continue to display throughout the burner run cycle and after shutdown when the unit returns to a satisfied and idle state.
4. Burner Combustion Adjustment - General
 - a. With the burner firing, measure the gas flow pressure at the beginning of the gas train. If the inlet gas flow pressure for Natural Gas is equal to or greater than 3.5 inches water column, or if the inlet gas flow pressure for Propane Gas is equal to or greater than 8.0 inches water column, continue with the startup. If the inlet gas flow pressure drops below these minimum requirements, a supply gas volume or piping problem may exist and must be corrected before the startup can continue.

- b. **IMPORTANT:** Under no circumstance should the dynamic (flow) pressure drop be more than two inches below the supplied static pressure for either natural gas or propane.
- c. Next, with the burner firing, monitor the combustion analyzer readings. The desired Carbon Dioxide (CO₂) level in the combustion products must be between 8.5 and 9.5% for Natural Gas and between 9.5 to 10.5% for Propane Gas. If the CO₂ level is within this range, no adjustment is required or recommended. If the CO₂ level is outside of these ranges, the combustion must be optimized.

WARNING: If at any point carbon monoxide exceeds 200 ppm, contact PVI Customer Care for assistance. [Is there a customer service number we can add?]

WARNING: Do not continue to operate the appliance with carbon monoxide levels above 200 ppm. Carbon monoxide is a colorless, odorless, and poisonous gas that commonly results from gas combustion. High concentrations of Carbon Monoxide are extremely dangerous to humans and animals. Operation of an appliance at carbon monoxide levels above 200 ppm can cause unsafe operation and the potential for poisonous carbon monoxide to enter occupied areas. Such improper installation can cause property damage, personal injury, exposure to hazardous materials, or death.

5. **Optimizing Combustion:** The Conquest uses a combination gas regulator and gas valve. If the CO₂ level must be adjusted, the firing rate should first be locked in the minimum firing rate setting. The firing rate adjustment is performed in the Manual Override Menu accessed through the EOS Touch Screen Digital Control. See Paragraph 6 of this section for Manual Override Menu instructions and detailed instructions for combustion adjustment. When adjusting combustion in Manual Override, you will be bypassing the setpoint. Ensure you do not create a scalding situation and you have enough hot water usage to complete combustion adjustments.
6. **Combustion Adjustments for All Models –** To access the Manual Override Menu:
 - a. Press and hold the **HOME** button for 3 seconds to enter the menu selection.
 - b. Touch the **NEXT ITEM** or **ITEM BACK** buttons to navigate to the **TOOLBOX** menu.
 - c. Touch the **ENTER** button to display the **ACCESS** screen.
 - d. Hold the #4 button to activate **ADVANCED**.
 - e. Exit the menu by pressing the **HOME** button.
 - f. Use the **NEXT ITEM** or **ITEM BACK** buttons to navigate to the **VERRIDE** menu.
 - g. Touch the Enter button to display the **MANUAL OVERRIDE** screen and use the **UP** or **DOWN** arrow buttons to select the **HAND** setting.
 - h. Use the **NEXT ITEM** or **ITEM BACK** buttons to navigate to the **HEATER MODULATION (HTR MOD)** menu. This setting will override the operating control and, using the up or down arrow buttons, force the burner to fire at a selected firing rate. **NOTE:** If the **HTR MOD** program is activated while the burner is firing, the burner will shut down and recycle. Caution, putting the heater in **HAND** changes the setpoint to 190F. Ensure you do not overheat the water system or cause damage. Ensure you have enough heat consumption to perform combustion adjustments.
 - i. Using the **UP** or **DOWN** arrow buttons, adjust the firing rate from **OFF** to the minimum firing rate **MIN MOD** for **Low Fire**. After the burner firing rate stabilizes at **Low Fire**, adjust the **Gas Regulator** screw clockwise to increase gas flow and increase CO₂ or counterclockwise to decrease flow and decrease CO₂. Adjust the regulator and orifice using the +/-.
 - j. Once the desired combustion levels are achieved at **Low Fire**, return to the Touch Screen, and increase the **HTR MOD** firing rate in 20% increments while monitoring the CO₂ level. At each interval the gas may be increased or decreased by using

the Valve Orifice Adjustment. Continue with this procedure until the High Fire firing rate setting **MAX MOD** allowed for the specific product has been achieved. **NOTE:** The maximum factory-set High Fire firing rate may not be 100%. After stabilizing, you can adjust High Fire. For all models, turn the Gas Valve Orifice Adjustment screw clockwise to decrease gas flow and decrease CO₂ or counterclockwise to increase gas flow and increase CO₂.

- k. Once the desired combustion is reached at **High Fire**, return to **Low Fire** to confirm the settings again. To achieve optimal combustion, it may be necessary to repeat the Low / High adjustments multiple times.
 - l. While in **HAND** mode, you can exit the **OVERRIDE** menu to observe the water temperature and re-enter the **OVERRIDE** menu. The heater will remain in **HAND** mode.
 - m. When all combustion adjustments are complete, go back to the **MANUAL OVERRIDE** screen and return the function back to the **“AUTO”** setting.
7. Check The Vent Pressure.
 8. With the combustion properly adjusted, now use the test hole in the flue vent to measure the vent pressure. With the burner firing, confirm that the vent pressure does not exceed .5” W.C. Pressure greater than .5” W.C. indicates a venting sizing issue that the installer must address before operating the water heater.

WARNING: When adjustments are complete and before putting the water heater into service, return the MAN OVR function to “AUTO.” Failure to do so can cause high water temperatures that can result in property damage, scalding, other serious injury, or death.

GAS TRAIN ILLUSTRATIONS

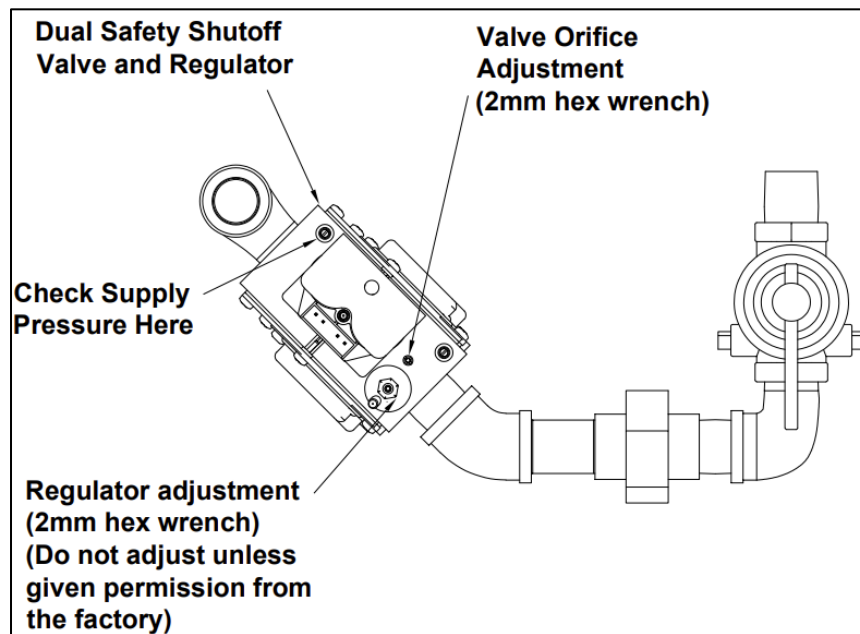

**Gas Train Illustration for Model CQT 400
(Optional components may not be shown)**

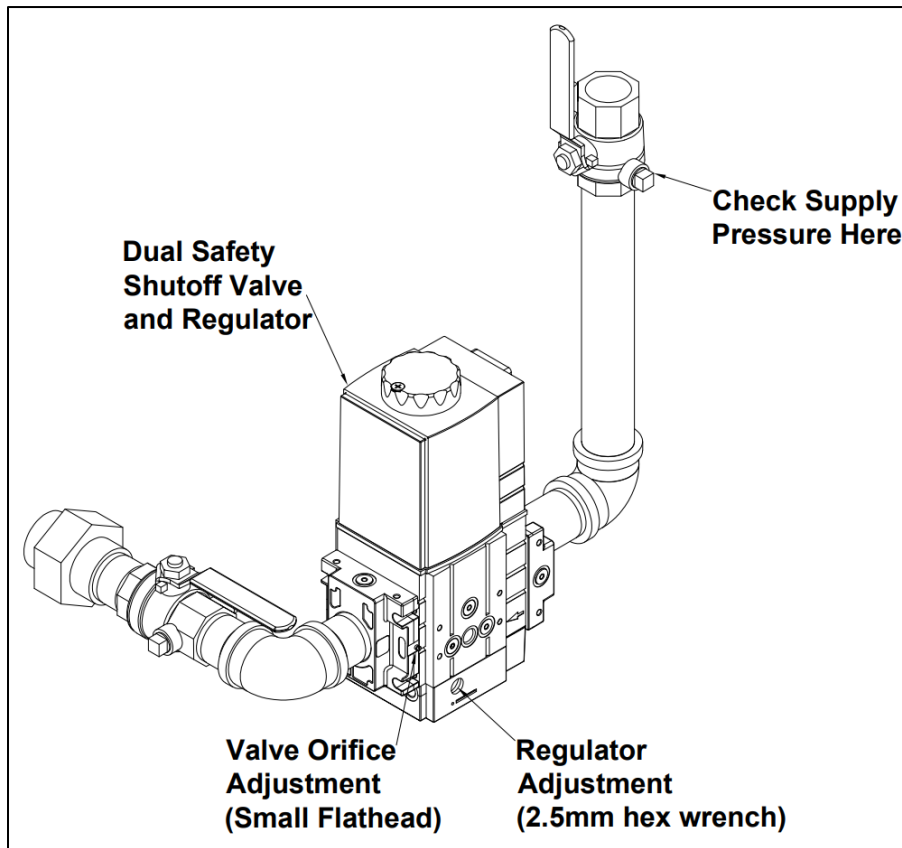

**Gas Train Illustration for Models CQT 500 – 1200
(Optional components may not be shown)**

SECTION 16: POTENTIOMETER (ADJUSTING THE SET-POINT)

The PIM Ignition Control will continue to operate the Conquest water heater at a 120-degree internal factory set-point should the touch screen control fail or communication between the two devices be interrupted. This internal set-point can be adjusted using the potentiometer to maintain a different operating temperature under these circumstances if desired. The OPERATOR is factory set to 120°F. If the PIM module is replaced, the OPERATOR will need to be adjusted.

TO ADJUST THE PIM POTENTIOMETER SET-POINT:

1. From the View Menu, press and hold the **HOME** button for 3 seconds to display the **SETUP** Menu.
2. Using the **NEXT ITEM** or **ITEM BACK** buttons, navigate to the **TOOLBOX** menu, then touch the **ENTER** button to display the **ACCESS** menu.
3. Now, use the **UP** or **DOWN** arrow buttons to select the **INSTALLER** setting.
4. Touch the **HOME** button to return to the menu selection, then use the **NEXT ITEM** or **ITEM BACK** buttons to navigate to the **SOURCE** menu.
5. Touch **ENTER** to enter the **SOURCE** menu and use the **NEXT ITEM** or **ITEM BACK** buttons to navigate to the **OPERATOR** screen to display the potentiometer set point.
6. Open the hinged upper panel of the control enclosure and locate the potentiometer on the PIM Ignition Module.
7. Use a small blade screwdriver to adjust the PIM Potentiometer to a desired stand-alone set-point temperature as you view the adjusted temperature setting in the **OPERATOR** screen.
8. Exit the menu by pressing the **HOME** button twice.
9. The **OPERATOR** screen will time out and you will need to navigate back to it. To help prevent this, while on the operator screen, hit **NEXT ITEM** and then **ITEM BACK** every couple of minutes to prevent the timeout while you make adjustments.

SECTION 17: NSF COMPLIANCE

All Conquest water heaters are certified for compliance with NSF/ANSI 372 by ETL Intertek and are, therefore, suitable for installation and use in commercial applications with low lead requirements.

While NSF/ANSI 61 establishes limits for lead that may migrate into drinking water from the plumbing system's water-contact materials, NSF/ANSI 372 establishes a limit on the amount of lead that may be contained within the water-contact materials in a drinking water-contact product, e.g., water heaters. NSF/ANSI 372 outlines general requirements relating to the lead content, including a maximum weighted lead content requirement of 0.25 percent.

SECTION 18: FOOD SERVICE INSTALLATION GUIDELINES

This section provides additional recommendations for architects, designers, and contractors in food service installations.

WARNING: Do not use a pressurized water source to clean this water heater. If the food service installation requires pressurized washing, the water heater must be isolated from water spray. Failure to isolate the heater from pressurized water may cause a hazardous condition resulting in property damage or high voltage electrical shock, causing personal injury or death.

Conquest water heaters can be adjusted to operate at temperatures up to 190°F. Refer to the “Temperature Setting” section of this manual for instructions to adjust the thermostat to the desired temperature.

Food Equipment Installation — Where feasible, the water heater should be located separate from food and utensil handling areas. When this is not possible in a food service installation, the water heater must be sealed to the floor to prevent water from accumulating underneath. The floor must be clean, smooth, and level for adequate sealing. Seal the water heater to the floor using an RTV sealant (such as Red Devil 0826, Safe-T-Lok 732 or RTV 102 or an equivalent). Follow the sealant manufacturer’s instructions to lay a bead of sealant between the edge of the heater base and the floor. The supplied covers over the four floor bolting access openings must be installed.

Food Equipment Service and Maintenance — If possible, during installation, ensure the appliance is sealed to prevent vermin harborage. The tight construction of the properly installed and assembled heater enclosure should not provide a haven for pests. If the floor bolting access covers do not seal completely, they must be replaced with direct replacement covers, available from PVI.

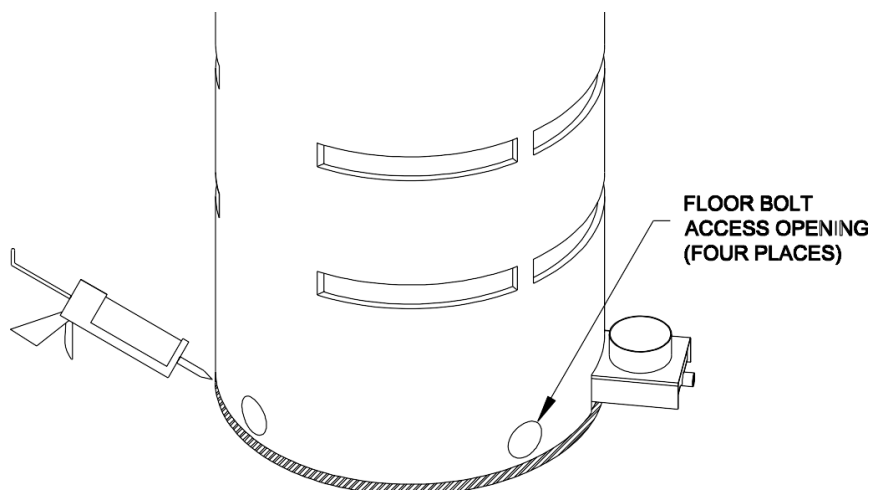

SECTION 19: INSTRUCTIONS FOR OUTDOOR MODELS

Additional steps should be considered when installing outdoor water heaters. If not otherwise stated, follow installation, start-up, and operational guidelines for the non-outdoor water heaters.

19.1 Flue Venting Termination

The following illustration provides for two vent termination options for outdoor water heater models. When choosing the preferred option, keep in mind that flue gas from condensing water heaters contains water droplets that can discolor or damage brick or masonry surfaces. Accumulation on nearby surfaces can also freeze under the right conditions.

WARNING: Do not exhaust flue gases near outside windows or building air intakes, which may allow gases to be introduced indoors.

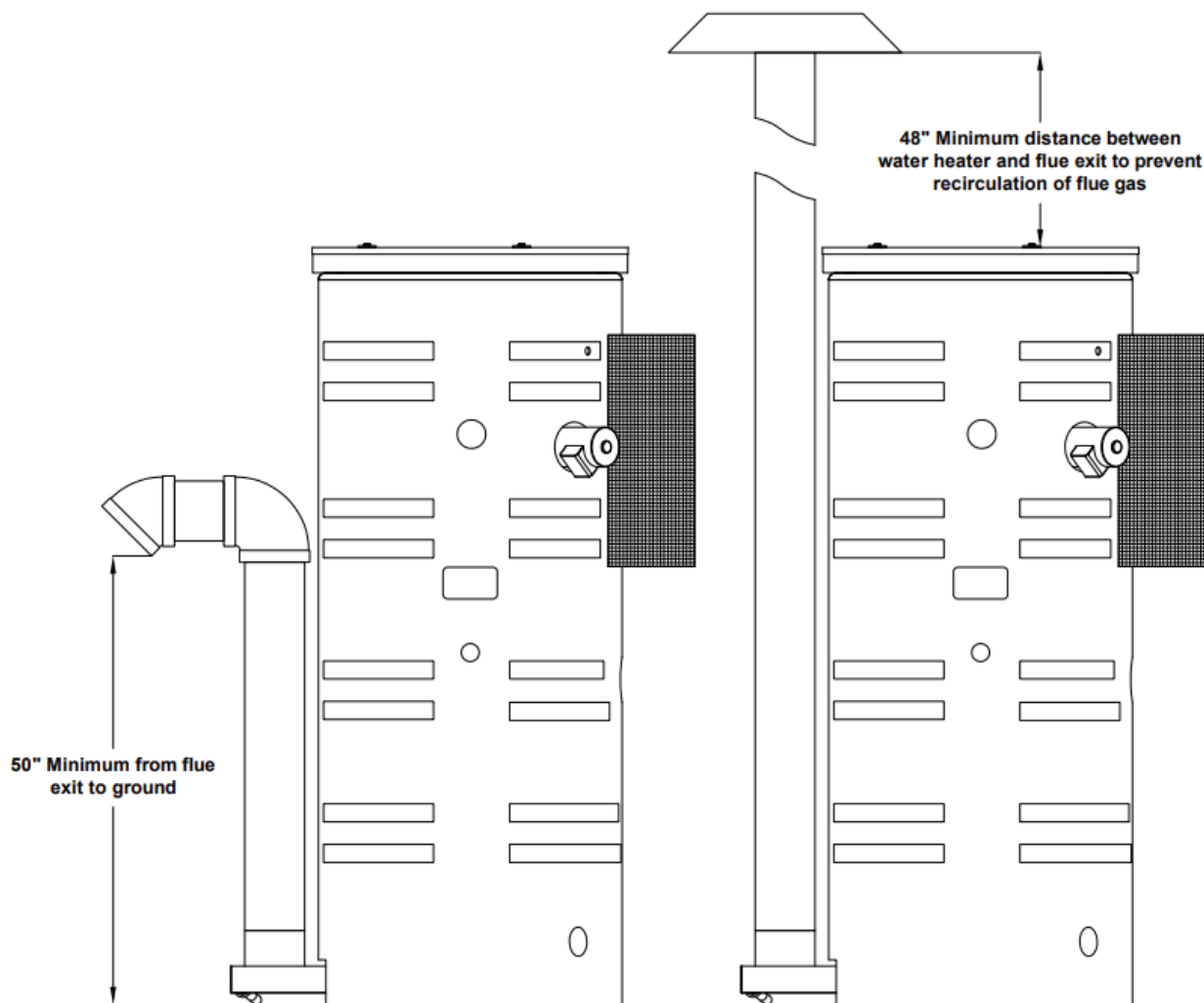

19.2 Condensate Drain

When the heater is operating in freezing conditions, the condensate drain and trap plumbing can freeze. A blockage of this plumbing will cause poor operation and the heater's eventual shut down. To prevent this occurrence, all unheated plumbing should be externally heated and wrapped with insulation.

19.3 Service and Control Adjustment Access

To access the burner, blower, gas train, and hot surface igniter, the outdoor air intake and cover must be removed. When the heater is installed under a roof or cover, at least 3 feet of clearance above the heater must be allowed for access. The illustration below details the access procedure.

19.4 Air Filter Cleaning

There is also an air filter (PN: 164604) located under the top cover, which should be cleaned or replaced every 6 months at a minimum. If the air contains especially high amounts of particulate, shorter filter maintenance intervals may be required. The illustration below details the access procedure. Consult the factory regarding indoor filtration.

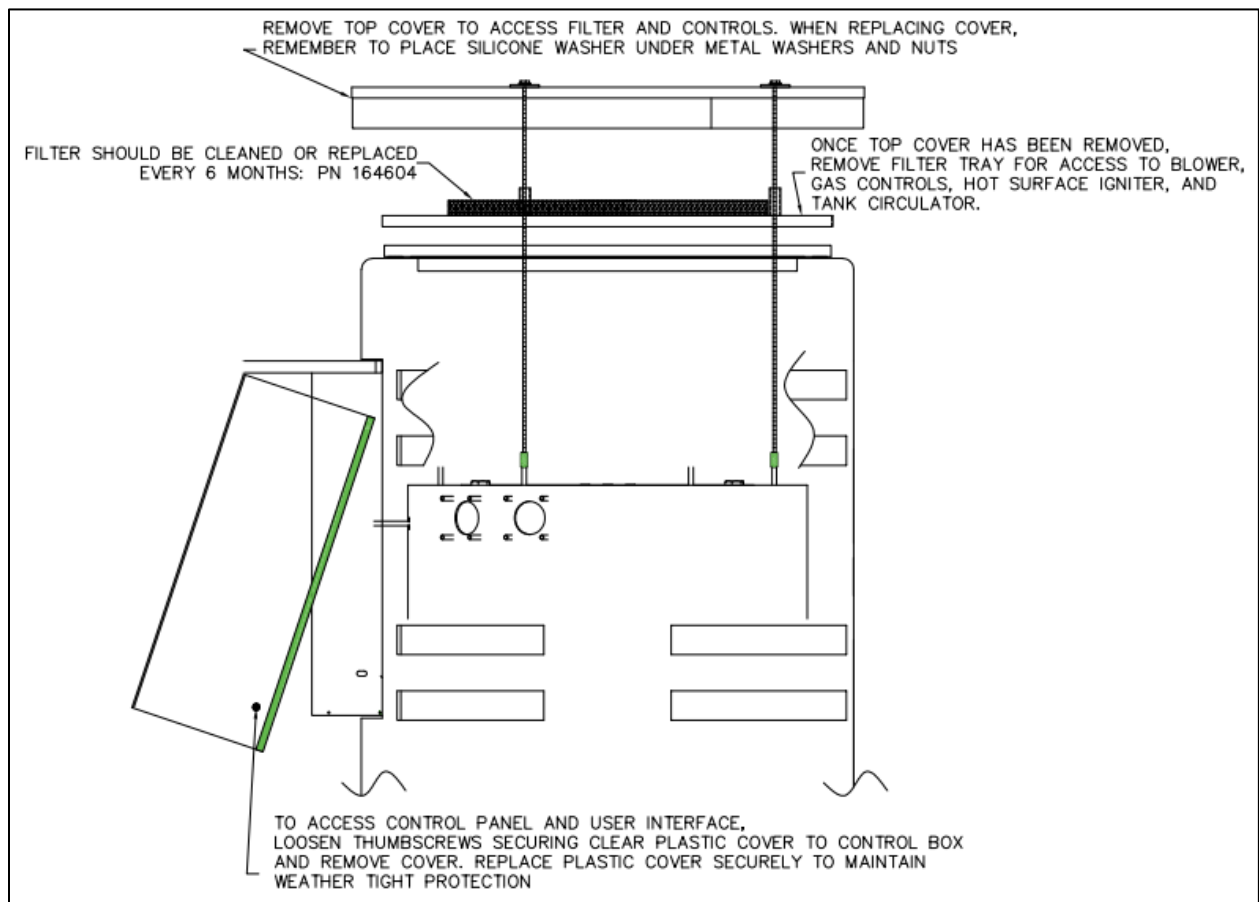

19.5 Control Enclosure Outdoor Cover

The clear plastic outdoor cover is a critical component for preventing water from entering the control enclosure. It is very important to replace the cover after connecting the electrical service or following any adjustments made to the EOS control. The on/off switch and resets are accessible without removing the outdoor cover.

SECTION 20: TROUBLESHOOTING PROCEDURE

Before troubleshooting the system, check the following items:

- Verify all mechanical and electrical connections are secure and tight.
- Verify all system wiring is correct.
- Verify that the igniter, flame sensor, and ignition module share a common ground with the burner. Poor or erratic ground connections often cause nuisance shutdowns.
- Follow the “Initial Startup” instructions in section 15 as the first step in any troubleshooting.
- Verify that the system is powered and that the EOS control is calling for heat.
- If the PIM module has an error code (blinking red LED), troubleshoot according to Section 11.2 Alarm Messages—Diagnostic Codes.

General Troubleshooting

Symptom	Probable Cause	Corrective Action
Starting or Pre-purge Failure	Power Supply	Check the fuse and/or circuit breaker.
	On-Off Switch	Check if the On-Off switch is illuminated when on. If not, check the panel fuse or incoming power.
	Temperature Control	Check that the operating temperature control is set higher than the temperature of the water heater.
	Remote enable/disable open	Enable the water heater or place the jumper between terminals R1-R2.
	Electronic Low Water Cut-off (Red LED is off or blinking)	Check the internal ELWCO board. A red LED not lit, or blinking indicates a failure. A manual reset is required.
	Gas Pressure Switches (when installed)	Gas pressure switches are attached to the gas train. Check for a tripped condition indicated by the manual reset button on the switch. Correct low gas pressure condition at the supply.
	High Temperature Limiting Device	The high limit device is set at 200°F and located at the control flange on the top head of the tank. A failure of the Temperature Control sensors or the circulation pump may cause a high-temperature condition, which requires a manual reset.
	Combustion Air blower	Check if the fan control relay is closed. The blower motor may have failed.
	Blower Speed Tachometer (if the blower is functioning)	Check for loose between the blower and control. Check the blower speed measurement with a Hz meter. Consult factory.
	Remote Proving Interlock	When terminals C1 and C2 are used as proving circuits for remote equipment, failure to close this circuit within the allotted time for Call-for-Heat will prevent operation and cause an alarm indication. Check for proper operation and proofing of remote equipment.
Loose Wire Connections	Check connections to all components.	

Symptom	Probable Cause	Corrective Action
Flame Failure	Power Supply	120 VAC is required for operation. Low voltage can cause failure. Voltage below 110 VAC must be investigated.
	Hot Surface Igniter	Check resistance at room temperature, and then the amperage draws during heat-up. Replace if the measured amperage is not within 3.5 to 5.0 Amps or if the measured resistance is not within 40- 100 ohms (at room temperature). Also, check for overheating. conditions due to damaged refractory around the igniter.
	Blower Speed Proving	EOS fault code will identify blower speed errors. May be a faulty blower.
	Gas Pressure	Check for proper inlet static and dynamic gas pressure, 3.5" W.C. minimum. Under no circumstance should the dynamic (flow) pressure drop be more than two inches below the supplied static pressure for either natural gas or propane.
	Combustion	Inadequate flame signal may result from improper combustion. Adjust to proper CO2 levels. The inability to achieve proper CO2 levels may be caused by a defective gas valve, a defective regulator, or a blockage in the burner or combustion air supply.
	Grounding	Check for proper ground from flame control to burner housing.
	Condensate Accumulation	Check that the condensation path from the heater to the drain is not blocked or that the neutralizer is installed so that the drain path travels uphill from the heater. For Conquest applied as a booster heater, verify that the inlet water general-purpose water heater is 140°F or higher.

20.1 LED Error Code Listing

The following table lists the errors detected by the Platform Ignition Module (PIM) control and the associated LED indications.

Error Mode	LED Code	Recommended Troubleshooting
Normal Operation	GREEN ON, RED OFF	
ID Card Fault	Red LED Steady ON, Green Power LED OFF	Check that the proper ID card is securely connected. Perform a power and system reset.
Internal Control Failure	RED Steady ON	Perform a power and system reset. If the fault remains, replace the PIM.
Airflow Fault	1 flash	Check Blower operation.
False Flame Error	2 flashes	Check for proper gas valve closure. Clean burner and electrodes.
Ignition Lockout Fault	3 flashes	Check the gas supply. See Section 6 for more information.
Ignition Proving Current Fault	4 flashes	Check the HSI element. Replace with a new element of the proper rating.
Low Voltage Fault	5 flashes	Check the 24 VAC input voltage. The voltage must be above 18.0 VAC
Vent Temperature Fault	6 flashes	Check for a blocked flue. Check the vent sensor and connections.
Hi-Limit Fault	7 flashes	Check for proper water flow. Check hi-limit and outlet sensors.
Sensor Fault	8 flashes	See the digital control display for fault identification. Check sensors and wiring.
Safety #1 Fault	9 flashes	Check the gas pressure. Verify proper safety switch operation.
Water Pressure Fault	10 flashes	Check piping for leaks. Check the pressure switch and connections.
Blower Speed Fault	11 flashes	Verify the tachometer signal and connection on J5.
LWCO Fault	12 flashes	Check the LWCO switch and connections. Check the water level.
Hi-Temperature Delta Fault	13 flashes	Check pump operation. Confirm proper water flow across the heat exchanger.
Ft-bus Communications Fault	14 flashes	Verify the digital control display is connected and operating. Check the cable between the control display and J1.
Safety #2 Fault	15 flashes	Check the gas pressure. Verify proper safety switch operation.

SECTION 21: REPLACEMENT PARTS (INDOOR MODELS ONLY)

21.1 Blower & Burner Assemblies (Models 400 – 1200)

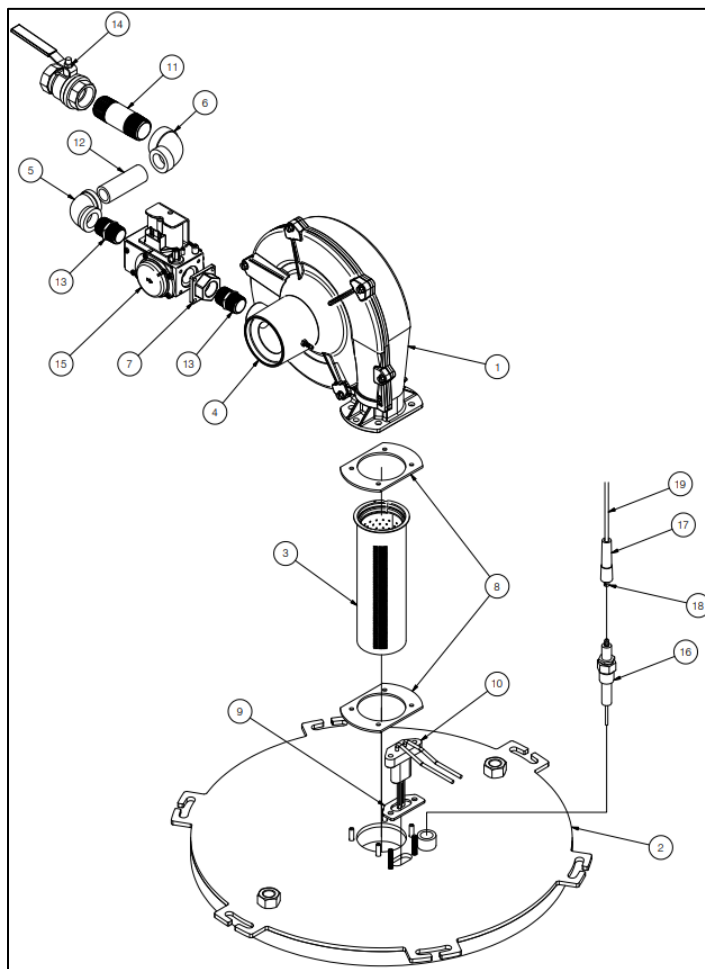

Model CQT 400
(Optional components may not be shown)

ITEM	DESCRIPTION	PART NUMBER
1	BLOWER, FASCO #70530041 120-240V 4.0A 50-60Hz 5900 RPM	140696
2	BULKHEAD, AGC G2 40-60 W/ INSULATION	162467
3	BURNER, BECKETT #PRX0827 70 X 315 MM DZ=28MM	162416
4	CAP, ORIFICE AGC 3.0 OD X 1 3/4 ID	128984
5	ELL, BLACK 90DEG 3/4	6160
6	ELL, BLACK REDUCING 90DEG 1 X 3/4	6164
7	FLANGE, VALVE 3/4 EBM-PAPST 27458.36060 FOR TYPE GB-ND	162415
8	GASKET, FLANGE BLOWER BURNER 1/8 232 CRANEGLS 2.75 ID	120493
9	GASKET, IGNITOR 1/8 232 CRANEGLS Y271	111791
10	IGNITER, HOT SURFACE NORTON #271Y MB478844 1 IN	107775
11	NIPPLE, BLACK 1 X 3 1/2	6013
12	NIPPLE, BLACK 3/4 X 2	5991
13	NIPPLE, BRASS 3/4 X CL MCMASTER-CARR #5485K25	162413
14	VALVE, SHUTOFF 1 GAS RUB #S82F41	148964
15	VALVE, GAS 3/4 EBM #55290.04007 TYPE GB-ND 057 D01	125504
16	ELECTRODE, FLAME CROWN #26779 W/ 1/2 X 14 GLAND	127816
17	BOOT, SILICONE STRAIGHT #514R RED	100490
18	CONNECTOR, SSN FEMALE #E9-SSN-PK	5249
19	WIRE, #16GA UL STYLE 3257 250 DEG C 10KV AC, 25KV DC 500	5732

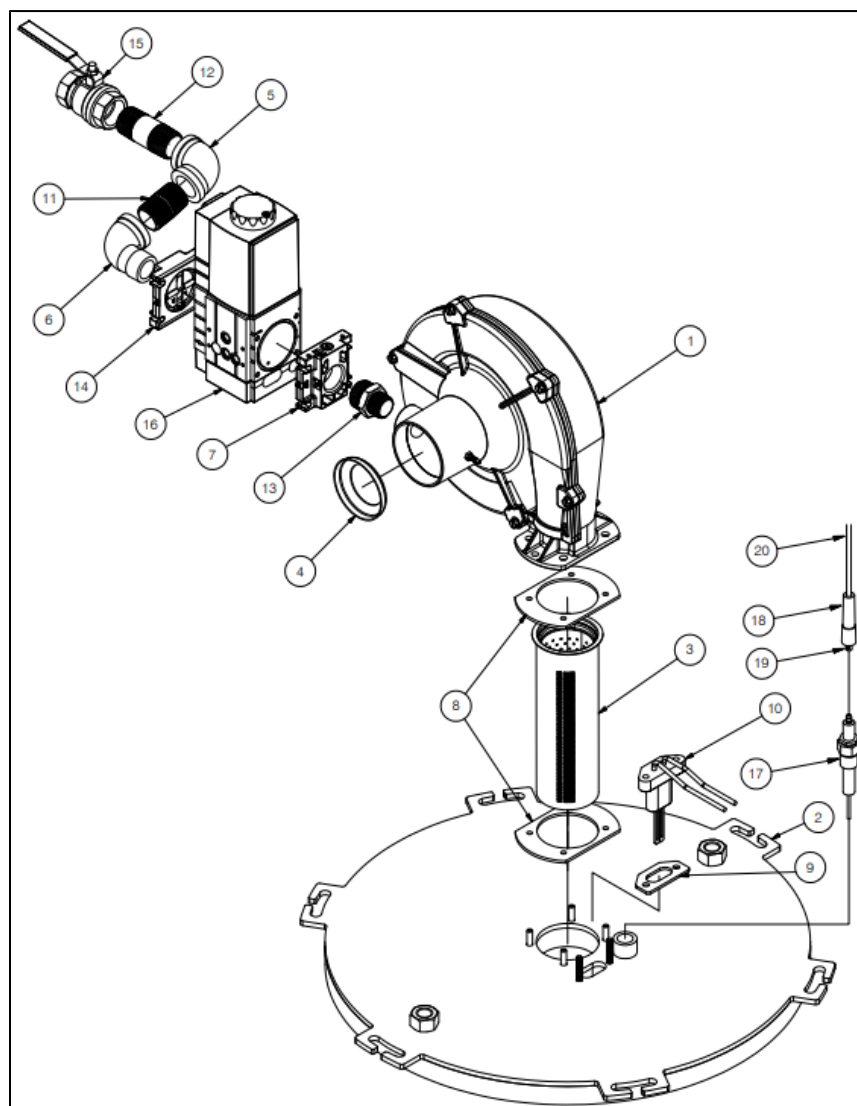

Models: CQT 500 and CQT 600

ITEM	DESCRIPTION	PART NUMBER
1	BLOWER, FASCO #70530041 120-240V 4.0A 50-60Hz 5900 RPM	140696
2	BULKHEAD, AGC G2 40-60 W/ INSULATION	162467
3	BURNER, BECKETT #PRX0827 70 X 315 MM DZ=28MM	162416
4	CAP, ORIFICE AGC 3.0 OD X 2 ID	128985
5	ELL, BLACK 90DEG 1	6163
6	ELL, STREET BLACK 90DEG 1	6185
7	FLANGE, VALVE DUNGS #DD221999	110308
8	GASKET, FLANGE BLOWER BURNER 1/8 232 CRANEGLS 2.75 ID	120493
9	GASKET, IGNITOR 1/8 232 CRANEGLS Y271	111791
10	IGNITER, HOT SURFACE NORTON #271Y MB478844 1 IN	107775
11	NIPPLE, BLACK 1 X 2	6011
12	NIPPLE, BLACK 1 X 3	6012
13	NIPPLE, BRASS STRAIGHT REDUCER, 1 X 3/4 MCMaster-CARR #50785K567	162414
14	SHUTTER, VALVE 1 DUNGS #255132 MBC1000	126862
15	VALVE, SHUTOFF 1 GAS RUB #S82F41 MODEL #S.82	148964
16	VALVE, GAS DUNGS #259487 120VAC	109884
17	ELECTRODE, FLAME CROWN #26779 W/ 1/2 X 14 GLAND	127816
18	BOOT, SILICONE STRAIGHT #514R RED	100490
19	CONNECTOR, SSN FEMALE #E9-SSN-PK	5249
20	WIRE, #16GA UL STYLE 3257 250 DEG C 10KV AC, 25KV DC 500	5732

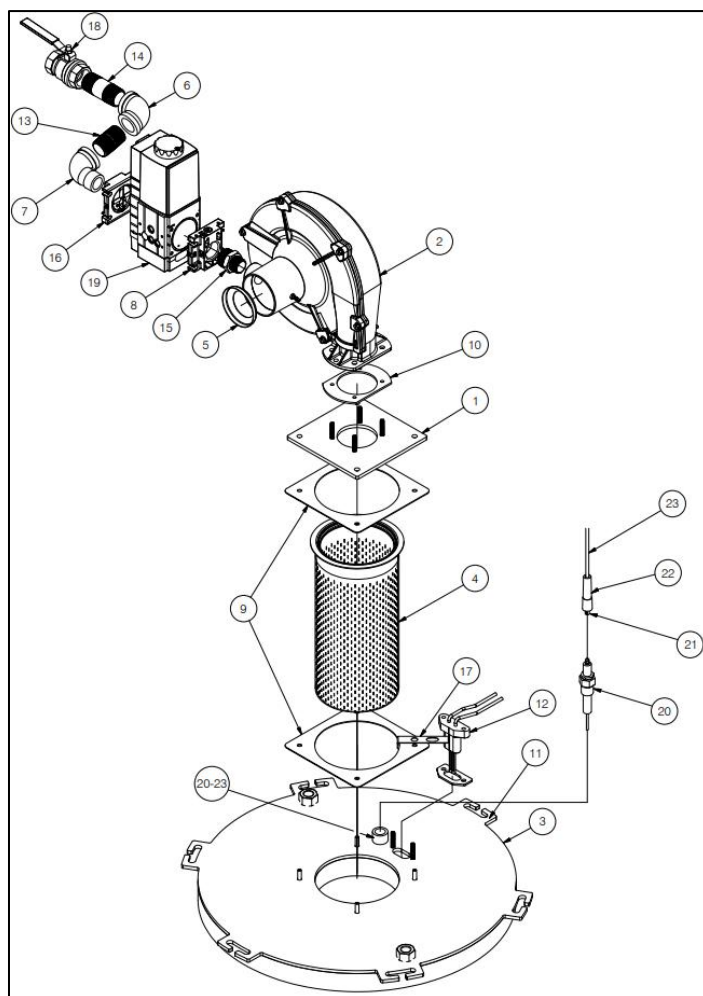

Models: CQT 700 and CQT 800

ITEM	DESCRIPTION	PART NUMBER
1	ADAPTER, BULKHEAD BLOWER 70-80 AGC G2 STUDS	162474
2	BLOWER, FASCO #70530041 12-240V 4.0A 50/60Hz 5900 RPM	140696
3	BULKHEAD AGC G2 70-120 W/ INSULATION	162379
4	BURNER, WORGAS #PRX0195 140 X 310MM DZ=43MM	126852
5	CAP, ORIFICE AGC 3.0 OD X 2 ID	128985
6	ELL, BLACK 90DEG 1	6163
7	ELL, STREET BLACK 90DEG 1	6185
8	FLANGE, VALVE DUNGS #DD221999	110308
9	GASKET, FLANGE BURNER AGC G2 1/8 232 CRANEGLAS 7.1 SQ X 5.75 ID	162451
10	GASKET, FLANGE BLOWER/BURNER 1/8 232 CRANEGLAS 2.75 ID	120493
11	GASKET, IGNITOR 1/8 232 CRANEGLAS Y271	111791
12	IGNITER, HOT SURFACE NORTON #271Y MB478844 1 1/2 IN	107774
13	NIPPLE, BLACK 1 X 2	6011
14	NIPPLE, BLACK 1 X 3	6012
15	NIPPLE, BRASS STRAIGHT REDUCER, 1 X 3/4 MCMaster #50785KK567	162414
16	SHUTTER, VALVE DUNGS #255132	126862
17	ASSY, BURNER GROUNDING TAB	128314
18	VALVE, SHUTOFF 1 GAS RUB #S82F41 MODEL #S.82	148964
19	VALVE, GAS DUNGS #259487 120VAC	109884
20	ELECTRODE, FLAME CROWN #26779 W/ 1/2 X 14 GLAND	127816
21	BOOT, SILICONE STRAIGHT #514R RED	100490
22	CONNECTOR, SSN FEMALE #E9-SSN-PK	5249
23	WIRE, #16GA UL STYLE 3257 250 DEG C 10KV AC, 25KV DC 500	5732

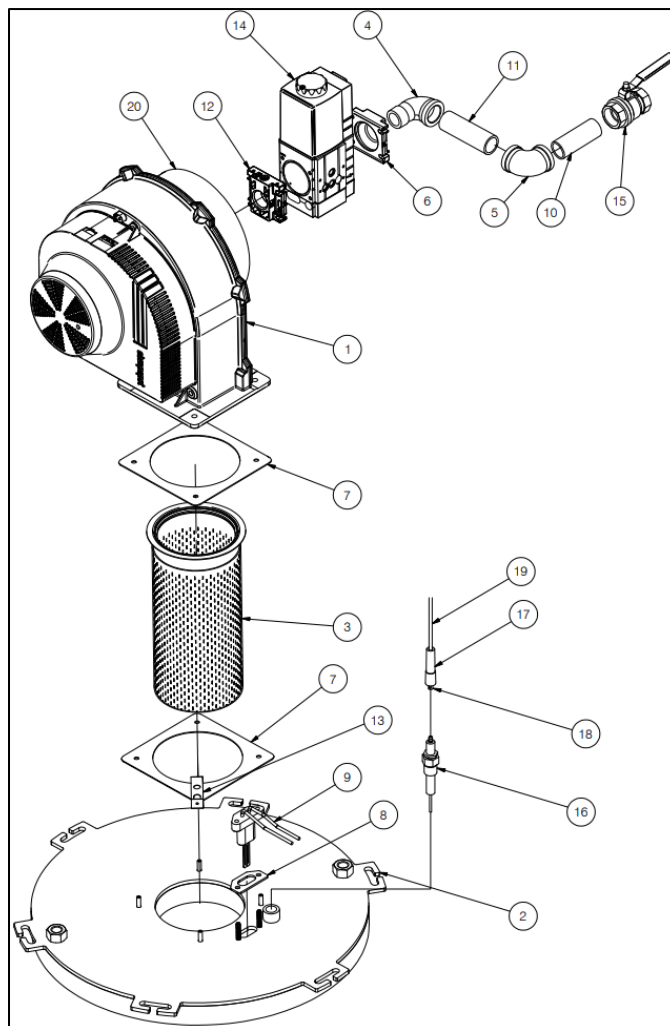

Models: CQT 900 – 1200

ITEM	DESCRIPTION	PART NUMBER
1	BLOWER, EBMPAPST #55600.03051	126337
2	BULKHEAD AGC G2 70-120 W/ INSULATION	162379
3	BURNER, WORGAS #PRX0195 140 X 310 MM DZ=43MM	126852
4	ELL, STREET BLACK 90 DEG 1	6185
5	ELL, BLACK 90DEG 1	6163
6	FLANGE, VALVE DUNGS#DD221999	110308
7	GASKET, FLANGE BURNER AGC G2 1/8 CRANE GLASS	162451
8	GASKET, IGNITOR 1/8 232 CRANEGLAS Y271	111791
9	IGNITER, HOT SURFACE NORTON #271Y MB478843 1 1/2 IN	107774
10	NIPPLE, BLACK 1 X 3 1/2	6013
11	NIPPLE, BLACK 1 X 4	6014
12	SHUTTER, VALVE DUNGS #255132	126862
13	ASSY, BURNER GROUNDING TAB	128314
14	VALVE, GAS DUNGS #259487 120VAC	109884
15	VALVE, SHUTOFF 1 GAS RUB #S82F41 MODEL #S.82	148964
16	ELECTRODE, FLAME CROWN #26779 W/ 1/2 X 14 GLAND	127816
17	BOOT, SILICONE STRAIGHT #514R RED	100490
18	CONNECTOR, SSN FEMALE #E9-SSN-PK	5249
19	WIRE, #18GA UL STYLE 3257 250 DEG C 10KV AC, 25KV DC 500	5732
20	WHIRLWIND SHROUD 9 O.D. X 3 5/16 PAINTED	163381

21.2 Control Panel Components

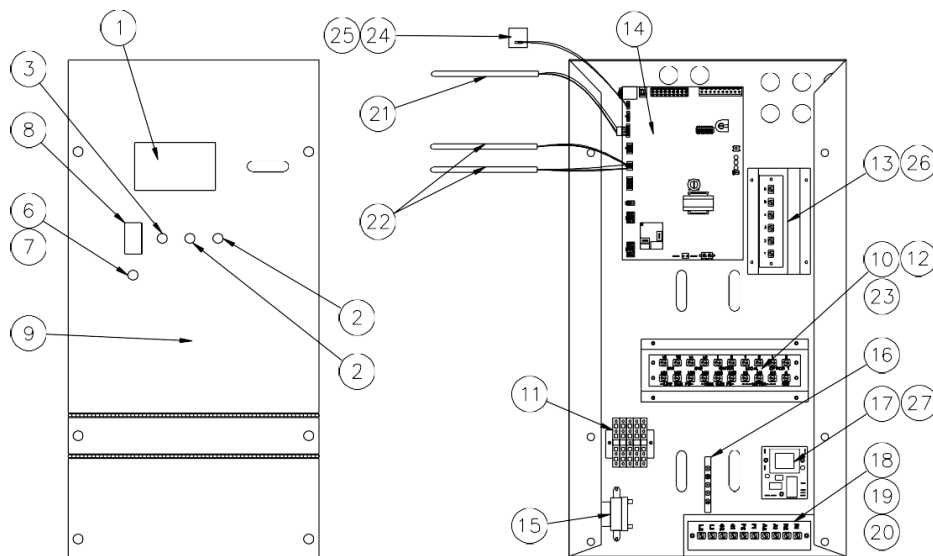

ITEM	DESCRIPTION	400	500	600	700	800	900	1000	1100	1200
1	Kit, EOS BTCII User Interface	148911	147308	147309	147310	147311	147313	147313	147313	147313
2	Switch, SPST N.C. Momentary Contact Selecta #SS229	70573	70573	70573	70573	70573	70573	70573	70573	70573
3	Switch, SPST N.O. Momentary Contact Selecta #SS228	75908	75908	75908	75908	75908	75908	75908	75908	75908
4	Face Plate Decal	145166	145166	145166	145166	145166	126335	126335	126335	126335
5	Screw 10-24 X 1/2	125249	125249	125249	125249	125249	125249	125249	125249	125249
6	Fuseholder, Panel Type #HTB-28I	5613	5613	5613	5613	5613	5613	5613	5613	5613
7	Fuse, MDA 10 Amp Buss 250V	76267	76267	76267	76267	76267	76267	76267	76267	76267
8	Switch, Carling #LTI5A1-6S-BL-AM-NBL-125N/LNDP	70565	70565	70565	70565	70565	70565	70565	70565	70565
9	Plate, Face AGC PIM/Digital Control Display	144569	144569	144569	144569	144569	145468	145468	145468	145468
10	Board, Terminal Elec-Tron #PV13080 20 Pole Feed	122346	122346	122346	122346	122346	122346	122346	122346	122346
11	Block, Terminal Wago #280-833 600V 20A DIN	122319	122319	122319	122319	122319	122319	122319	122319	122319
12	Jumper, Terminal Block Wago #280-402 23A	122320	122320	122320	122320	122320	122320	122320	122320	122320
13	Board, Terminal Elec-Tron #Es-70x Pv04075 6 Pole Feed Thru Type	103259	103259	103259	103259	103259	103259	103259	103259	103259
14	Kit, PIM Control	148912	147301	147302	147303	147304	147306	147306	147306	147306
15	Transformer, Step Down Triad #F5-24 115VAC 24VCT	126865	126865	126865	126865	126865	126865	126865	126865	126865
16	Bar, Ground Square D #PK5GTA 5 Pole	122321	122321	122321	122321	122321	122321	122321	122321	122321
17	LWCO, Protodesign #LW-3-C-1-A-03 120V	129013	129013	129013	129013	129013	129013	129013	129013	129013
18	Board, Terminal Elec-Tron #PV13140 10 Pole	140328	140328	140328	140328	140328	140328	140328	140328	140328
19	Bracket, Terminal Strip Mtg 3 X 6 for P/N 102011	121749	121749	121749	121749	121749	121749	121749	121749	121749
20	Jumper, Elec-Tron #ESJ-145	102467	102467	102467	102467	102467	102467	102467	102467	102467
21	Sensor, Thermistor Tekmar #91769 Direct Measure Dual	126090	126090	126090	126090	126090	126090	126090	126090	126090
22	Sensor, Thermistor Tekmar #91768 Direct Measure Single	126089	126089	126089	126089	126089	126089	126089	126089	126089
23	Jumper, Elec-Tron #ESJ-154	122746	122746	122746	122746	122746	122746	122746	122746	122746
24	Card, Pim Fenwal #05-900000 Water heater	143364	143364	143364	143364	143364	143365	143365	143365	143365
25	Card Cable Fenwal #05-900001-018	126537	126537	126537	126537	126537	126537	126537	126537	126537
26	Bracket, Terminal Strip Mtg 3 X 6 Angle Face for P/N 103259	145267	145267	145267	145267	145267	145267	145267	145267	145267
27	Probe, LWCO Warrick #3L1D002.75 w/1/8 MPT	58154	58154	58154	58154	58154	58154	58154	58154	58154

21.3 Drain Valve – T & P Relief Valve – Integral Circulating Pump Assembly

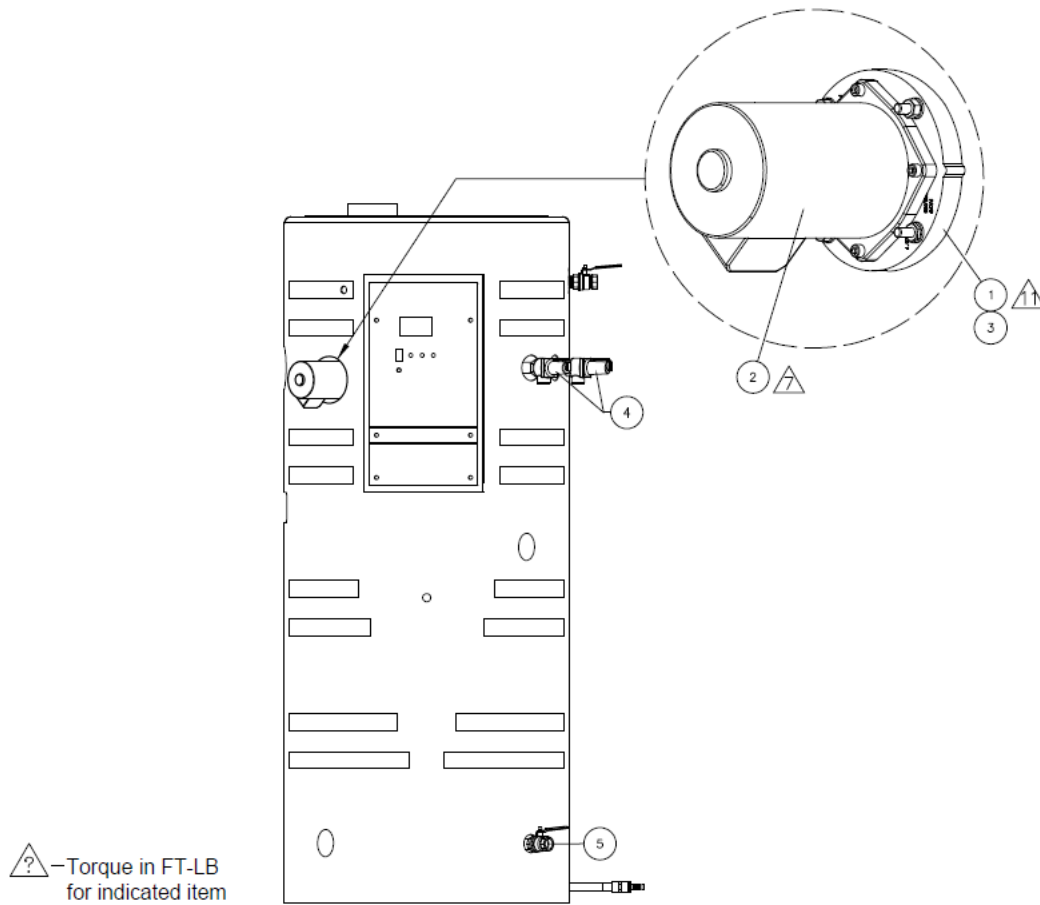

ITEM	DESCRIPTION	PART NUMBER
1	FLANGE, MTG BRONZE INTEGRAL PUMP PL 2 SIDE	165760
2	MOTOR, PUMP B&G #1BL140 MODEL #PL-130 115 VAC	143510
3	O-RING, GASKET 4.25 OD X 3.50 ID X .375 – (Flange to Tank)	122423
4	VALVE, T & P RELIEF 1 WATTS #140X-6 150 PSI 670 M 3085	709
5	VALVE, BALL 1 WATTS #LFFBV-3C BRASS THREADED 400 WOG	122394

21.4 Condensate Drain Trap & Optional Condensate Neutralizer

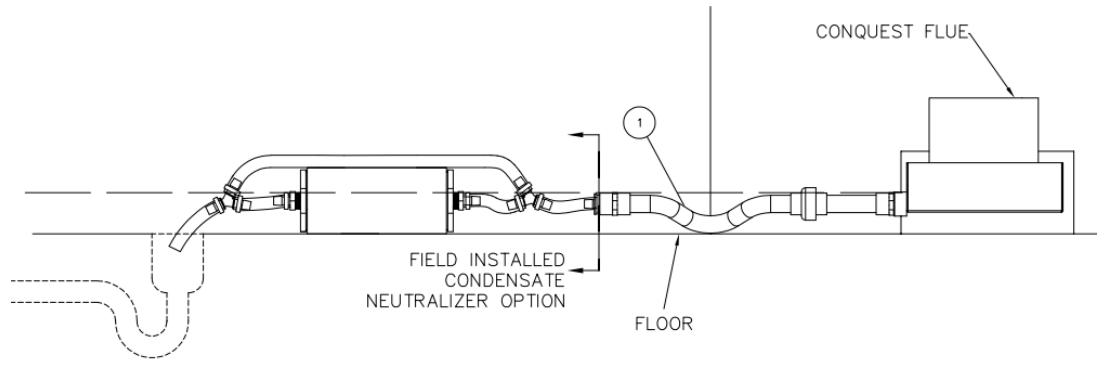

ITEM	DESCRIPTION	PART NUMBER
1	PKG, COND DRAIN AGC G2 130 GAL 3/4 PVC FOR 40-120	162382

*tubing and tee fittings not supplied in this kit

21.5 Component Wiring and Routing Details

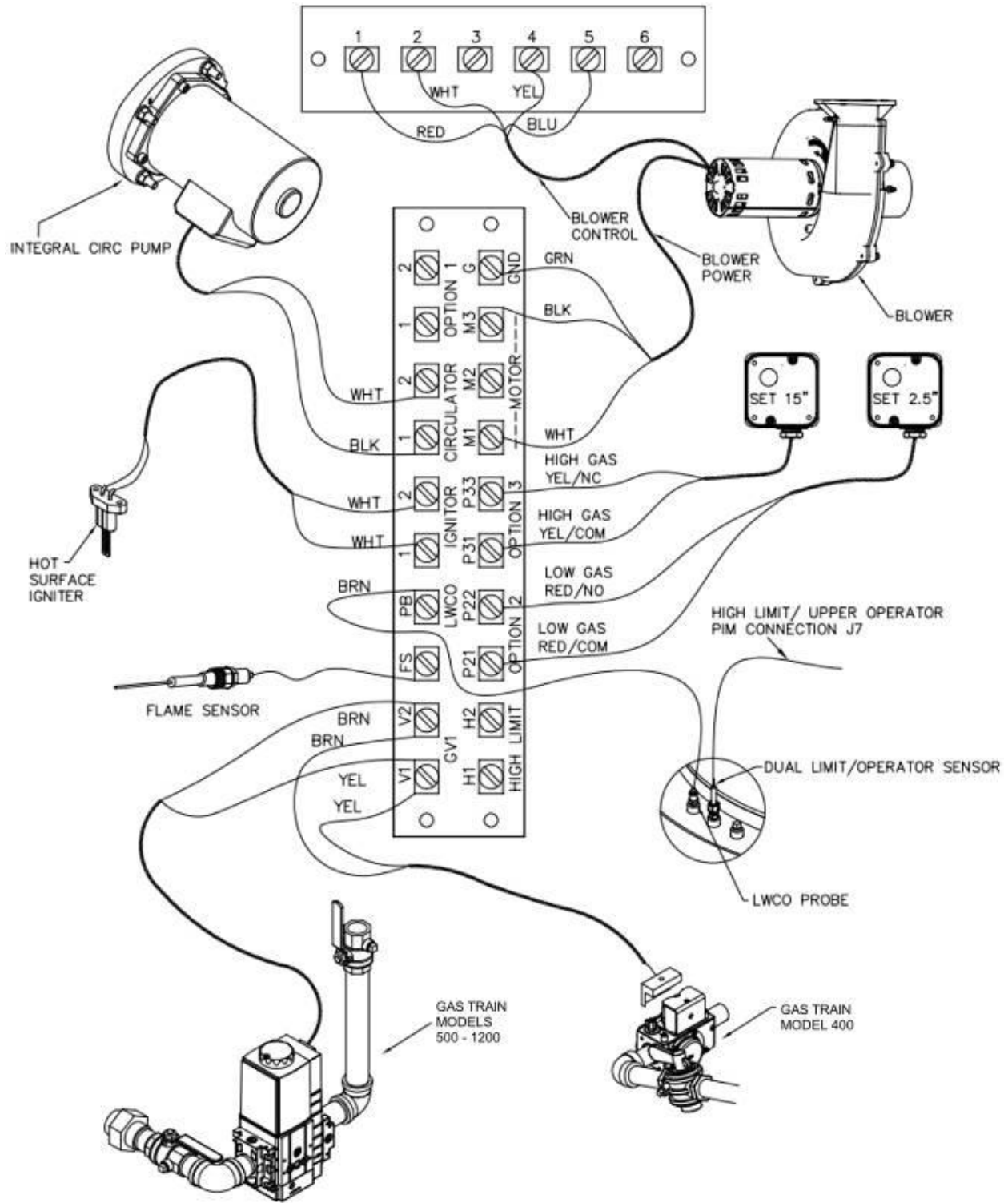

SECTION 22: PERIODIC MAINTENANCE GENERAL

Listed below are items that must be checked to ensure reliable operations. Maintenance must be performed by a qualified service or maintenance provider. To ensure proper maintenance, the following instructions should be posted near the appliance and maintained in legible condition. Verify proper operation after servicing.

WARNING: When servicing the controls, use exact, Factory-authorized replacement parts and label all wires prior to disconnection. Verify proper operation after servicing. Incorrect parts substitution and wiring errors can cause damage, improper operation, fire, carbon monoxide, exposure to toxic fumes, or other unexpected and unsafe conditions that can result in fire, personal injury, or death.

1. Examine the appliance and venting system at least once a year. Check more often in the first year to determine the inspection interval.
 - a. Check all joints and pipe connections for tightness, corrosion, or deterioration.
 - b. Check the electronic ignition system for quick ignition and a proper flame signal.
 - c. Check all safety controls, including thermostats, for proper operation.
 - d. Check safety shut-off valves for operation and tightness.
 - e. Keep appliance area clear and free from combustible materials, gasoline, and other flammable vapors and liquids.
 - f. Have the entire system, including but not limited to the burner, heat exchanger, and venting system, periodically inspected by a qualified service agency.
2. Exposure to Dusty or Dirty Combustion Air: An appliance installed in a dusty or dirt-contaminated atmosphere will require more frequent inspection and cleaning of the burner to prevent nuisance shutdowns or premature burner failure.
3. Any sign of soot on the heat exchanger or in the flue indicates the need for a combustion inspection. Properly installed and adjusted units seldom need heat exchanger cleaning. If soot has formed, the most common causes are restricted combustion air or excessive gas. A blocked heat exchanger can cause unsafe operation and will reduce efficiency. To inspect and clean the heat exchanger, a qualified service agent or installer should use the procedures described in items 4, 5, & 6 below.
4. All gaskets on disassembled components must be replaced on reassembly with exact, factory-authorized replacement parts only. Gasket kits are available from your PVI Industries® Representative or by contacting PVI Industries®, LLC.
5. **Burner and/or Heat Exchanger Inspection and Cleaning Procedure:**
Do not attempt the following procedure without a spare hot surface ignitor (HSI) available.
 - a. Turn off the main power to the unit.
 - b. Turn off the gas supply.
 - c. Write notes and/or take pictures during this process to aid in correct reassembly.
 - d. Remove the metal cover on top of the appliance by disconnecting the fasteners and holding it to the plastic jacket.
 - e. Disconnect the quick-connect electrical plugs at the blower and at the gas valve.
 - f. Remove the hot surface ignitor (HSI) from the burner. Due to its fragility, be very careful not to bump the igniter element.
 - g. Break the unions that connect the gas train to the blower and the gas supply pipe. Remove the gas train.
 - h. Remove the nuts that attach the blower to the burner top plate and remove the blower. The burner can now be extracted. Be careful not to damage the refractory or the blower burner gaskets when removing the burner.

- i. With the burner removed, inspect the deck surface for lint or other blockage carried in the fuel air stream. If blockage has accumulated, use a brush to loosen debris, and vacuum or water to remove it from the burner cavities.
 - j. The combustion chamber and refractory can be inspected without removing the bulkhead. **The bulkhead should only be removed when there are obvious signs of damage and a replacement part is available.**
 - k. Replace any damaged components and reassemble them in reverse order. (4-5 ft/lbs).
 - l. Cycle the unit and test to verify that all safety and operating controls are properly functioning, and the burner/blower components are free of leaks.
6. **Replacement of the Refractor Bulkhead:**
Always wear gloves and a mask while handling refractory. If replacement parts are not available, care should be taken not to damage the refractory.
- a. Follow the disassembly instructions outlined the section 5 above.
 - b. Remove the nuts that secure the bulkhead to the combustion chamber.
 - c. Inspect the bulkhead refractory for damage. The refractory must provide a tight seal against the top edge of the burner deck.
 - d. Replace any damaged components and reassemble them in reverse order. (4-5 ft/lbs).
 - e. Cycle the unit and test to verify that all safety and operating controls are properly functioning and that the burner bulkhead plate and burner/blower components are free of leaks.
7. Inspect the integral circulation pump gaskets and pump motor for leaks or failure. For information about the pump's operation, see the Troubleshooting Guide.
 8. Inspect the low water cutoffs and relief valves for proper operation every six months or more often if indicated by an inspection.
 9. The temperature and pressure relief valve should be checked at regular intervals to determine its condition for safe operation. Take proper precautions while operating the relief valve to avoid contact with hot water discharge from the relief valve and to prevent water damage. The openings inside the valve may become inoperative. If the valve does not open and close properly when tested, it must be replaced. If a relief valve discharges periodically, this may be due to thermal expansion in a closed water supply system. Contact a plumbing contractor or engineer to correct the situation. Do not plug the relief valve. Replace the relief valve with one that meets or exceeds the requirements.
 10. Keep the appliance area clear and free from combustible materials, gasoline, and other flammable vapors and liquids.
 11. Check frequently to be sure the flow of combustion and ventilation air to the appliance is unobstructed.
 12. When electrical controls are serviced or replaced, label all connections as they are removed to know their proper locations on the replacement part.
 13. All replacement parts are available through your PVI Industries® Dealer. If you need assistance identifying or contacting your local dealer, you may contact PVI directly at the telephone number located on the first and last page of this manual.
 14. If the appliance is to be shut down for an extended period, the primary gas valve and the water supply should be shut off. When the appliance is returned to service, any standing water in the tank must be flushed, and a thorough inspection of all utilities and general appliance condition should be conducted.

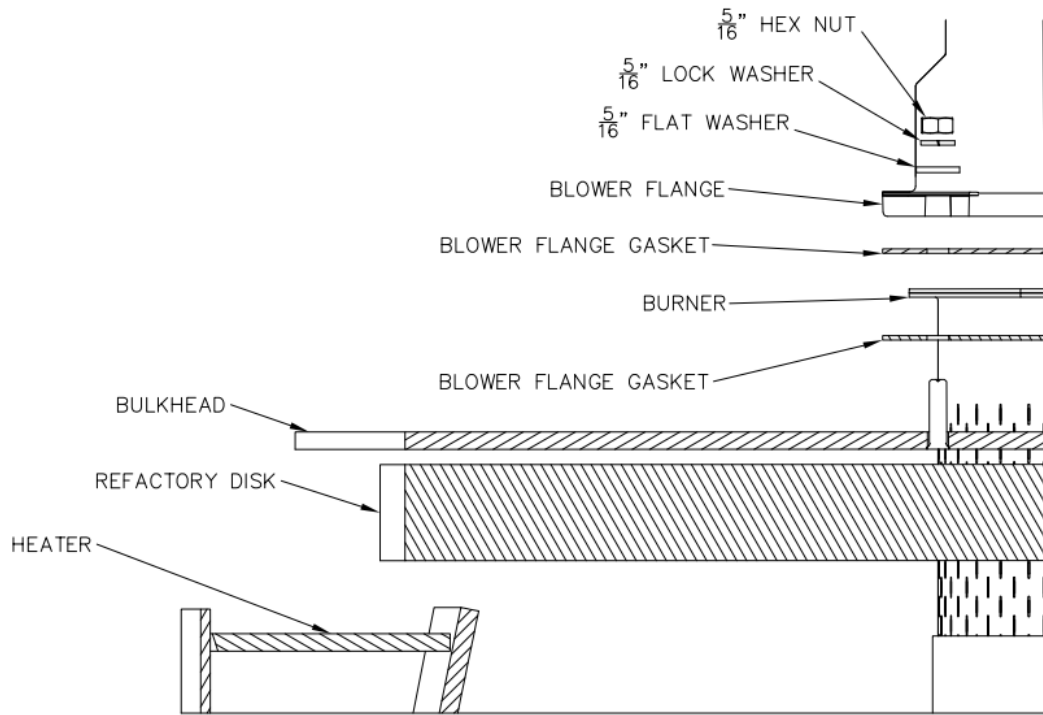

Burner Attachment Layering Illustration

SECTION 23: RECOMMENDED MAINTENANCE SCHEDULE

To ensure safe, reliable, and efficient operation, regular service by a qualified service agency and routine maintenance must be performed.

Yearly (Every 12 Months)

Schedule annual service calls by qualified service agencies.

1. Check for piping leaks around pumps, relief valves, and tank connections. If found, repair them.
2. Check to ensure the area is free from combustible materials, gasoline, and other flammable vapors or liquids.
3. Visually inspect the venting system for proper function, deterioration, or leakage.
4. Check temperature and pressure relief valve. Refer to the manufacturer's instructions on the valve.
5. Inspect the condensate drain and ensure condensate is directed to an appropriate condensate system or drain, as required by local codes.
6. Check all operations of safety devices. Refer to the manufacturer's instructions.
7. Inspect burner and gas train components for wear or deterioration.
8. Check the electronic ignition system for quick ignition and proper flame signal.
9. Check gas safety shut-off valves for proper operation and tightness.
10. Follow the startup procedure in the Installation & Maintenance Manual.

Semi-Annually (Every Six Months)

- Test Low-water-cut-off. Hold the LWCO TEST button for 10 seconds. When a need for heat is present, the heater will lock out. Hold RESET for 30 seconds to reset the lockout.
- Test the electronic-ignition flame failure detection system. While the heater is heating, shut off the gas supply to kill the flame. The heater should shut down and try to light three times hard knockout. Open the gas valve, and then hold RESET for 10 seconds to reset the lockout condition.

Monthly

- Check the condensate drain system and refill the condensate neutralizer with replacement media (change interval as needed).
- Visually inspect the venting system for proper function, deterioration, or leakage.
- Confirm the low-water cutoff and alarm are operating.

Daily

- Check for and remove any obstruction to the flow of combustion or ventilation air to the unit.
- Check to ensure the area is free from combustible materials, gasoline, and other flammable vapors or liquids.
- Check gauges, monitors, and indicators.

As Required

- Open the drain to remove any accumulated sediment. Start annually and adjust as local conditions and water quality require.
- Flush and clean the tank as required.

SECTION 24: MASSACHUSETTS REQUIREMENTS

This equipment complies with Massachusetts State Fuel Gas and Plumbing Codes CMR 248 3.00-10.00.

1. For all side wall, horizontally vented, gas-fueled equipment installed in every dwelling, building, or structure used in whole or in part for residential purposes, including those owned or operated by the Commonwealth and where the side wall exhaust vent termination is less than seven (7) feet above finished grade in the area around the venting, including but not limited to decks and porches, the following requirements shall be satisfied:
 - a. **INSTALLATION OF CARBON MONOXIDE DETECTORS:** At the time of installation of the side wall horizontal vented gas-fueled equipment, the installing plumber or gasfitter shall observe that a hard-wired carbon monoxide detector with an alarm and battery back-up is installed on the floor level where the gas equipment is to be installed. In addition, the installing plumber or gasfitter shall observe that a battery-operated or hard-wired carbon monoxide detector with an alarm is installed on each additional level of the dwelling, building, or structure served by the side wall horizontal vented gas-fueled equipment. It shall be the responsibility of the property owner to secure the services of qualified licensed professionals for the installation of hard-wired carbon monoxide detectors.
 - i. If the sidewall, horizontally vented, gas-fueled equipment is installed in a crawl space or an attic, the hard-wired carbon monoxide detector with alarm and battery backup may be installed on the next adjacent floor level.
 - ii. If the requirements of this subdivision cannot be met at the time of installation completion, the owner shall have thirty (30) days to comply with the above requirements, provided, however, that during said thirty (30) day period, a battery-operated carbon monoxide detector with an alarm shall be installed.
 - b. **APPROVED CARBON MONOXIDE DETECTORS:** Each carbon monoxide detector required by the above provisions shall comply with NFPA 720, be ANSI/UL 2034 listed, and be IAS certified.
 - c. **SIGNAGE:** A metal or plastic identification plate shall be permanently mounted to the exterior of the building at a minimum height of eight (8) feet above grade directly in line with the exhaust vent terminal for the horizontally vented gas-fueled heating appliance or equipment. The sign shall read, in print size no less than one-half (1/2) inch in size, "GAS VENT DIRECTLY BELOW. KEEP CLEAR OF ALL OBSTRUCTIONS".
 - d. **INSPECTION:** The state or local gas inspector of the side wall horizontally vented gas-fueled equipment shall not approve the installation unless, upon inspection, the inspector observes carbon monoxide detectors and signage installed in accordance with the provisions of 248 CMR 5.08(2)(a)1 through 4.
2. **EXEMPTIONS:** The following equipment is exempt from 248 CMR 5.08(2)(a)1 through 4:
 - a. The equipment listed in Chapter 10, entitled "Equipment Not Required To Be Vented" in the most current edition of NFPA 54 as adopted by the Board; and
 - b. Product-approved side wall horizontally vented gas-fueled equipment installed in a room or structure separate from the dwelling, building, or structure used in whole or in part for residential purposes.
3. **MANUFACTURERS REQUIREMENTS – GAS EQUIPMENT VENTING SYSTEM REQUIRED:** When the manufacturer of Product Approved side wall horizontally mounted gas equipment provides a venting system design or venting system components with the equipment, the instructions provided by the manufacturer for the installation of the equipment and the venting shall include:
 - a. Detailed instructions for the installation of the venting system or the venting system components: and
 - b. A complete parts list for the venting system design or venting system.
4. **MANUFACTURER REQUIREMENTS – GAS EQUIPMENT VENTING SYSTEM NOT PROVIDED:** When the manufacturer of product-approved side wall horizontally vented gas-fueled equipment does not provide the parts for the venting of flue gases but identifies "special venting systems," the following requirements shall be satisfied by the manufacturer:
 - a. The referenced "special venting system" instructions shall be included with the appliance or equipment installation instructions; and
 - b. The "special venting systems" shall be product approved by the Board, and the instructions for that system shall include a parts list and detailed installation instructions. Detailed installation instructions and parts list are available online for the following venting systems for use on this equipment:

Heat Fab Website – Saf-T-Vent EZ-Seal Installation & Maintenance Instructions <http://www.heatfab.com/products/saf-t-vent/saf-t-vent-ez-seal.asp?xid=x1>

Metal-Fab Website – Metal-Fab CORR/GUARD Installation & Maintenance Instructions http://www.metal-fabcommercial.com/content/products/corr_guard

Selkirk Metalbestos Website – Saf-T-Vent EZ-Seal (same as Heat Fab) Installation & Maintenance Instructions <http://www.selkirkusa.com/products/venting.aspx>
5. The relief valve must be installed and plumbed in accordance with the authority having jurisdiction. Massachusetts 248 CMR requires the relief valve to discharge 12 inches off the finished floor.
6. At the completion of the installation, a copy of all installation instructions for all side-wall horizontally vented gas-fueled equipment, all venting instructions, all parts lists for venting instructions, and/or all venting design instructions shall remain with the appliance or equipment.



© PVI Industries, LLC, 2024