

## Technical Data Sheet

# Durawatt<sup>®</sup>

## Electric Packaged Water Heater

PVI's Durawatt is an energy-efficient, emission-free electric water heater with storage capacity. It is designed to support a wide range of building electrification and decarbonization projects as it is 100% electric, burns no fuel, and is an extremely environmentally friendly solution when electricity is sourced from renewables.

Underscored by an industry-leading warranty, Durawatt offers a durable, reliable electric water heating solution. The storage tank is fabricated with AquaPLEX<sup>®</sup> duplex stainless steel which is highly corrosion-resistant and allows for higher storage temperatures. The design of individual incoloy sheathed heating elements simplifies maintenance and protects from damaging corrosive media.

Durawatt can be added to heat pump systems for more energy efficient, reliable domestic hot water delivery by providing backup heating, mitigating recirculation losses, and adding hot water storage.



### Key Features

- Up to 98% thermal efficiency
- 9kW to 234kW\*
- 568 to 7571-liter storage\*
- AquaPLEX duplex alloy unlined storage tank (no anode rods needed)
- Non-ferrous, removable tank connections
- Incoloy heating elements can be energized in up to 10 stages
- Supply voltages of 208/3, 240/3, 380/3, 480/3 (standard) or 600/3

### Designed for Durability and Simpler Maintenance

- Industry-leading 25-year tank warranty (15 full, 10 prorated)
- AquaPLEX storage tank is highly corrosion resistant
- Built with an inherently corrosion-proof, non-ferrous tank fitting
- Individual Incoloy sheathed heating elements for simplified, cost-efficient replacement
- No gas line, venting or consumables and fewer moving parts can reduce maintenance requirements compared to gas water heaters

### Customizable to Site-Specific Needs

- Energy input up to 360 kW and tank size up to 11356 liters
- Combine with another fuel type in a single tank for dual fuel option
- Electropolished incoloy for more aggressive potable water
- Custom fabrication for deionized and reverse osmosis water

### Ideal for a Variety of Applications

- Stand-alone, fully electric water heating plant with ample storage for peak demand
- Backup heating, recirculation loss mitigation, and hot water storage in heat pump systems
- Combined with gas-fired solution or select a dual fuel option (custom fabrication) for versatility

\*Customizable up to 360kW and 11356 liters.

# Dimensions

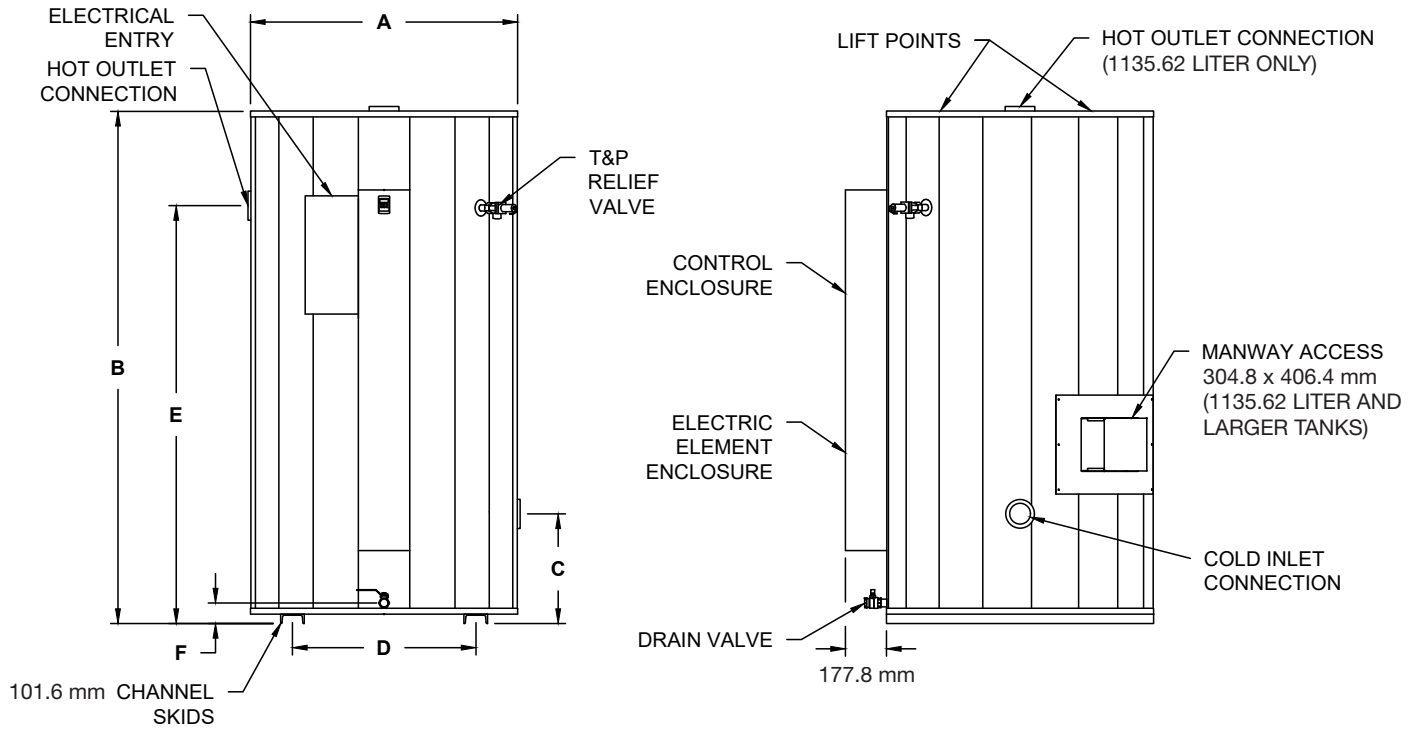

Tank Series 568-7571 Liters									
Liter Storage	Dimensions in mm						Water Inlet and Outlet Connections mm	Drain Valve mm	Approx. Shipping Weight kg
	A	B	C	D	E	F			
568	863.6 x 939.8	1651	406.4	533.4	1295.4	65	50.8	25.4	512.6
757		1854.2			1498.6				553.4
946		2159			1803.4				573.8
1136	1168.4	1905	482.6	787.4	@top	70	50.8	25.4	587.4
1514		2209.8			1778				607.8
1893	1422.4	1981.2	584.2	787.4	1498.6	30	76.2	38.1	800.6
2271		2286			1803.4				902.6
2839	1701.8	2108.2	584.2	1016	1600.2	76.2	76.2	38.1	966.2
3407		2413			1905				1065.9
3785		2717.8			2209.8				1165.7
9464	1905	2438.4	584.2	1193.8	1930.4	87	76.2	38.1	1537.7
5678		2743.2			2235.2				1635.2
6624		3352.8			2844.8				1834.8
7571		3657.6			3149.6				2050.2

Dimensions are in millimeters unless otherwise noted.  
 For larger storage capacities, consult factory.  
 Includes R-12.5 insulation.  
 ASHRAE 90.1 compliant.

PVI reserves the right to change the design and specification without notice.  
 Tank sizes 3785, and 5678-7571 liters include horizontal shipping skids (not shown).

# Electrical Connection

Sizes (208V 1Ø, 240V 1Ø, 208V 3Ø, 240V 3Ø, 380V 3Ø, 480V 3Ø, 600V 3Ø)

Model Prefix	kW	Btu/hr	Recovery Rate LPH		240V 3Ø			380V 3Ø			480V 3Ø			600V 3Ø		
			4.4°-49°C	4.4°-49°C	Amps	No.	Size MCM	Amps	No.	Size MCM	Amps	No.	Size MCM	Amps	No.	Size MCM
45	9	30,709	46	37	24	3	2/0	16	3	2/0	13	3	2/0	11	3	2/0
90	18	61,419	92	74	46	3	2/0	29	3	2/0	24	3	2/0	19	3	2/0
140	27	92,128	138	111	67	3	2/0	43	3	2/0	35	3	2/0	28	3	2/0
180	36	122,837	184	147	89	3	2/0	57	3	2/0	46	3	2/0	37	3	2/0
230	45	153,546	230	184	111	3	2/0	70	3	2/0	57	3	2/0	45	3	2/0
270	54	184,256	276	221	132	3	2/0	84	3	2/0	67	3	2/0	54	3	2/0
320	63	214,965	323	258	154	3	350	98	3	2/0	78	3	2/0	63	3	2/0
370	72	245,674	369	295	176	3	350	111	3	2/0	89	3	2/0	71	3	2/0
410	81	276,384	415	332	197	3	350	125	3	2/0	100	3	2/0	80	3	2/0
460	90	307,093	461	369	219	3	350	139	3	2/0	111	3	2/0	89	3	2/0
510	99	337,802	507	406	241	3	350	152	3	350	122	3	2/0	97	3	2/0
550	108	368,511	553	442	262	6	500	166	3	350	132	3	2/0	106	3	2/0
650	126	429,930	645	516	306	6	500	193	3	350	154	3	350	123	3	2/0
740	144	491,348	737	590	349	6	500	221	3	350	176	3	350	141	3	2/0
830	162	552,767	829	664	392	6	500	248	3	350	197	3	350	158	3	350
920	180	614,186	922	737	436	6	500	275	3	500	219	3	350	175	3	350
1010	198	675,604	1014	811	478	6	500	303	3	500	240	3	350	193	3	350
1100	216	737,023	1106	885	522	6	500	330	3	500	262	6	500	210	3	350
1200	234	798,441	1198	958	565	6	500	358	3	500	283	6	500	228	3	350

Model Prefix	kW	Btu/hr	Recovery Rate LPH		208V 3Ø		
			4.4°-49°C	4.4°-49°C	Amps	No.	Size MCM
45	9	30,709	46	37	27	3	2/0
90	18	61,419	92	74	52	3	2/0
140	27	92,128	138	111	77	3	2/0
180	36	122,837	184	147	102	3	2/0
230	45	153,546	230	184	127	3	2/0
270	54	184,256	276	221	152	3	350
320	63	214,965	323	258	177	3	350
370	72	245,674	369	295	202	3	350
410	80	272,971	410	328	224	3	350
460	90	307,093	461	369	253	6	500
510	99	337,802	507	406	278	6	500
540	105	358,275	538	430	294	6	500
610	120	409,457	614	492	336	6	500
690	135	460,639	691	553	378	6	500
770	150	511,821	768	614	419	6	500
840	165	563,003	845	676	461	6	500
920	180	614,186	922	737	503	6	500
1000	195	665,368	998	799	545	6	500
1080	210	716,550	1075	860	Consult Factory		
1160	225	767,732	1152	922			
1240	240	818,914	1229	983			

Model Prefix	kW	Btu/hr	Recovery Rate LPH		208V 1Ø			240V 1Ø		
			4.4°-49°C	4.4°-49°C	Amps	No.	Size MCM	Amps	No.	Size MCM
45	9	30,709	46	37	45	3	2/0	40	3	2/0
90	18	61,419	92	74	89	3	2/0	77	3	2/0
140	27	92,128	138	111	132	3	2/0	115	3	2/0
180	36	122,837	184	147	175	3	350	152	3	350
230	45	153,546	230	184	218	3	350	190	3	350
270	54	184,256	276	221	262	6	500	227	3	350
320	63	214,965	323	258	305	6	500	265	6	500
370	72	245,674	369	295	348	6	500	302	6	500
410	81	276,384	415	332	391	6	500	340	6	500
460	90	307,093	461	369	435	6	500	377	6	500
510	99	337,802	507	406	478	6	500	415	6	500
550	108	368,511	553	442	521	6	500	452	6	500
650	126	429,930	645	516	Consult Factory					
740	144	491,348	737	590						
830	162	552,767	829	664						
920	180	614,186	922	737						
1010	198	675,604	1014	811						
1100	216	737,023	1106	885						
1200	234	798,441	1198	958						

All distribution blocks on the connection side are rated for 600V.

Refer to the latest edition of the National Electrical Code for conductor sizing.

6.2 w/cm<sup>2</sup> elements are standard for up to 370 prefix; 12.4 w/cm<sup>2</sup> elements are standard for 370 prefix and more.

**Standard Electrical Requirements**

Control circuit transformer supplied and AC neutral conductor for grounding.

**Alternate Voltages**

For 230/460V, multiply kW and recovery by .92. multiply AMPS by .96.

For 220/440V, multiply kW and recovery by .84. multiply AMPS by .92.

# Standard and Optional Equipment



## Standard Features and Equipment

### Pressure Vessel

- AquaPLEX tank (unlined duplex stainless steel)
- ASME stamped and National Board Registered for 10.3 bar Maximum Allowable Working Pressure
- Nonferrous, removable fittings at all tank connections
- ASME-rated temperature and pressure relief valve
- 304.8 x406.4 mm manway access on 1136 liter tank series and larger, removable top head ≤ 946 liter
- Non-ferrous, removable tank fittings
- Fiberglass insulation and coated steel jacket panels
- Bottom drain valve
- Tie down anchor points on tank
- Lifting lugs

### Heating Elements

- Heavy-duty Incoloy® heating elements rated at 6.2 Watts per square cm heat density up to 370 prefix. Prefixes above 370 require 12.4 Watts per square cm heat density

### Electrical Circuitry

- Supply voltages available: 208V, 3Ø ; 240V, 1Ø ; 240V, 3Ø ; 380V, 3Ø ; 480V, 3Ø ; 600V, 3Ø
- 120V control circuit via supplied transformer
- Fused magnetic contactors for each power circuit (50 amp maximum per circuit on 3Ø units)
- Control circuit switch, fuse and pilot light
- Remote on-off terminals
- Safety door interlock

### Operating and Safety Controls

- Programmable electronic operating control with digital temperature readouts
- Immersion high-temperature limit
- Electronic low-water cutoff with test and reset

### Warranty and Service Policy

- 25-year tank warranty (PV901)<sup>1</sup>
- 1-year electric element warranty (PV535)<sup>1</sup>
- 1-year cost-free service policy (PV551)<sup>1</sup>
- Conditions exist outside of the continental US

## Codes and Standards

- Intertek/ETL listed
  - UL1453 / CAN/CSA-C22.2 No. 110-94
  - NSF 372 lead free
- ASHRAE 90.1 compliant

## Miscellaneous

- Factory authorized startup (available on most models check with PVI representative for details)

## Factory Options Packages

### 3 Alarm and Communications Package

- 485 serial cable to connect electronic operator to BAS (Modbus RTU)
- Alarm with switched contacts for remote notification
- 95dB local audible alarm with silencing switch

### Factory Installed Individual Options

- A** CSA-rated temperature and pressure relief valve(s)
- E** Water pressure gauge on drain piping
- F** Electronic proportional sequencer with indicating lights (72kW and higher)
- N** Celsius functionality for operating control

### Field Installed Options

(Ordered as a line item)

- Protocol gateways (Avail. with Option Package 3
  - Bacnet MSTP
- Installation kit (PN 143405)

### Optional Service Policy

Long-life service policy (PV559)<sup>1</sup>

*Conditions exist outside of the continental US*

### Custom Configuration

Consult representative for additional custom options

### Part Number Sequence

Base Model# + "Packages" + "Options" + "Voltage/Phase"

Example: 370 L 250AVE-3AE480V3

<sup>1</sup>See complete warranty and service policy for full details

PVI reserves the right to change the design and specification without notice.



Hot Water Solutions

PVI Industries • Fort Worth, TX

USA: T: (817) 335-9531 • Toll Free: (800) 784-8326 • PVI.com

Technical Support • (800) 433-5654 • Mon-Fri, 8 am - 5 pm CST/CDT