



## Installation, Operation & Maintenance Manual

# EZ Plate<sup>®</sup> Storage Water Heater Boiler Water Energy Source



**Important:** This manual contains information required for installation, operation and maintenance of this equipment. Read and follow the information in this manual and all other provided instructions, labels and markings before installing, operating or servicing this unit.

Installation and service must be performed by a qualified service installer, service agency or the gas supplier.

**To the installer:** After installation, these instructions must be given to the equipment user or left near the appliance.

**Special instructions to the owner:** Retain this manual for future reference. These instructions contain important information that will help you in maintaining and operating this appliance.



Manufacturing ASME Commercial Water Heaters Since 1961

PVI-500-64 • 07/2018

PVI Industries • 3209 Galvez Avenue • Fort Worth, TX 76111  
USA: T: (817) 335-9531 • Toll Free: (800) 784-8326 • PVI.com  
Technical Support • (800) 433-5654 (ext. 3) • Mon-Fri, 8 am - 5 pm CST

© 2019 PVI

# EZ Plate™ Storage Water Heater

## TABLE OF CONTENTS

- 1 Safety Considerations**
- 2 Product Descriptions**
- 3 Water Heater Installation**
  - 3.1 Warranty
  - 3.2 Checking Equipment Before You Install
  - 3.3 Codes
  - 3.4 Electrical Requirements
  - 3.5 Handling and Locating the Water Heater
  - 3.6 Service Clearances and Clearance to Combustibles
- 4 General Piping Guidelines**
  - 4.1 Potable Water Inlet and Outlet Connections
  - 4.2 Storage Tank Relief Valve Piping
  - 4.3 Cathodic Protection
  - 4.4 Boiler Water Piping
  - 4.5 Heat Exchanger Relief Valve Piping
  - 4.6 Connecting Pump(s) and Valves (if equipped)
  - 4.7 Filling the Unit
- 5 Operating and Safety Controls**
  - 5.1 High Water Temperature Limit Controls
  - 5.2 Electronic Low Water Cut-Off (optional)
- 6 TEMPTRAC Electronic Controller Panel**
  - 6.1 Principle of Operation
  - 6.2 Upper LED Readout
  - 6.3 Lower LED Readout
  - 6.4 Control Buttons
  - 6.5 Key Combinations
  - 6.6 LED Icon Legend
  - 6.7 To View the Setpoint
  - 6.8 To Change the Setpoint
  - 6.9 To Set the Current Time and Day (Military Time)
  - 6.10 To Set the Energy Saving Time (Nighttime Setback)
  - 6.11 To Set Modulation Parameters
  - 6.12 To Change Other Parameters
  - 6.13 LED Display Alarm Messages
  - 6.14 Audible Alarm
  - 6.15 Alarm Recovery
- 7 Description of Operation**
  - 7.1 Sequence of Operation
  - 7.2 Dual Heat Exchanger Operation
- 8 Start-Up and Shut-Down Procedure**
- 9 Maintenance**
  - 9.1 Temperature and Pressure Relief Valve
  - 9.2 Thermostats and Temperature Limiting Device
  - 9.3 Control Valve Actuator (if Supplied)
  - 9.4 Tank
  - 9.5 Heat Exchanger
  - 9.6 Optional Boiler Water Valve Package
  - 9.7 Checking and Adjusting 2-Way or 3-Way Valve Operation
  - 9.8 Recommended Maintenance Schedule
- 10 Troubleshooting Notes**

**Warranty and Startup forms ship separately with each water heater.**

# EZ Plate™ Storage Water Heater

## 1 SAFETY CONSIDERATIONS

**WARNING:** Do not use this appliance if any part has been under water. Immediately call a qualified service technician to inspect the unit and to replace any part of the control system and any other items affecting safe appliance operation and which has been under water. Failure to follow these instructions can cause property damage, personal injury, or exposure to hazardous materials or death.

### ***IMPORTANT SAFETY NOTE***

*It takes only 5 seconds of skin contact with 140 °F water to cause a second degree burn! You must protect against high water temperatures at all lavatories, tubs, showers and other points of hot water contact.*

***Accidental scalding from high water temperatures is a greater risk in some types of installations. Some examples are:***

***HOMES FOR THE MENTALLY OR PHYSICALLY HANDICAPPED***

***HOSPITALS AND NURSING HOMES***

***ELDER CARE FACILITIES AND REST HOMES***

***ORPHANAGES AND CHILD CARE FACILITIES***

***OTHER INSTALLATIONS - WHERE RESPONSE TO CONTACT WITH HOT WATER MAY BE SLOWER OR WHERE THE DANGER OF HOT WATER CONTACT IS GREATER.***

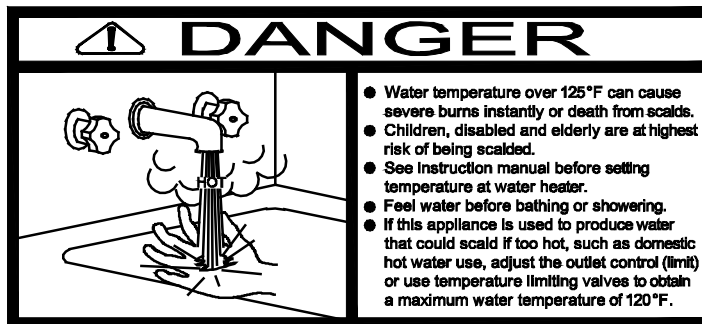

***Thermostatically controlled mixing valves must be used in the design of the potable hot water system. Potable hot water should be tempered to no more than 110°F when used for bathing or other personal uses.***

***Good engineering practice mandates the use of thermostatically controlled mixing valves set at 120°F or less to keep the delivered water temperature below scalding temperatures.***

# EZ Plate™ Storage Water Heater

## 2 PRODUCT DESCRIPTION

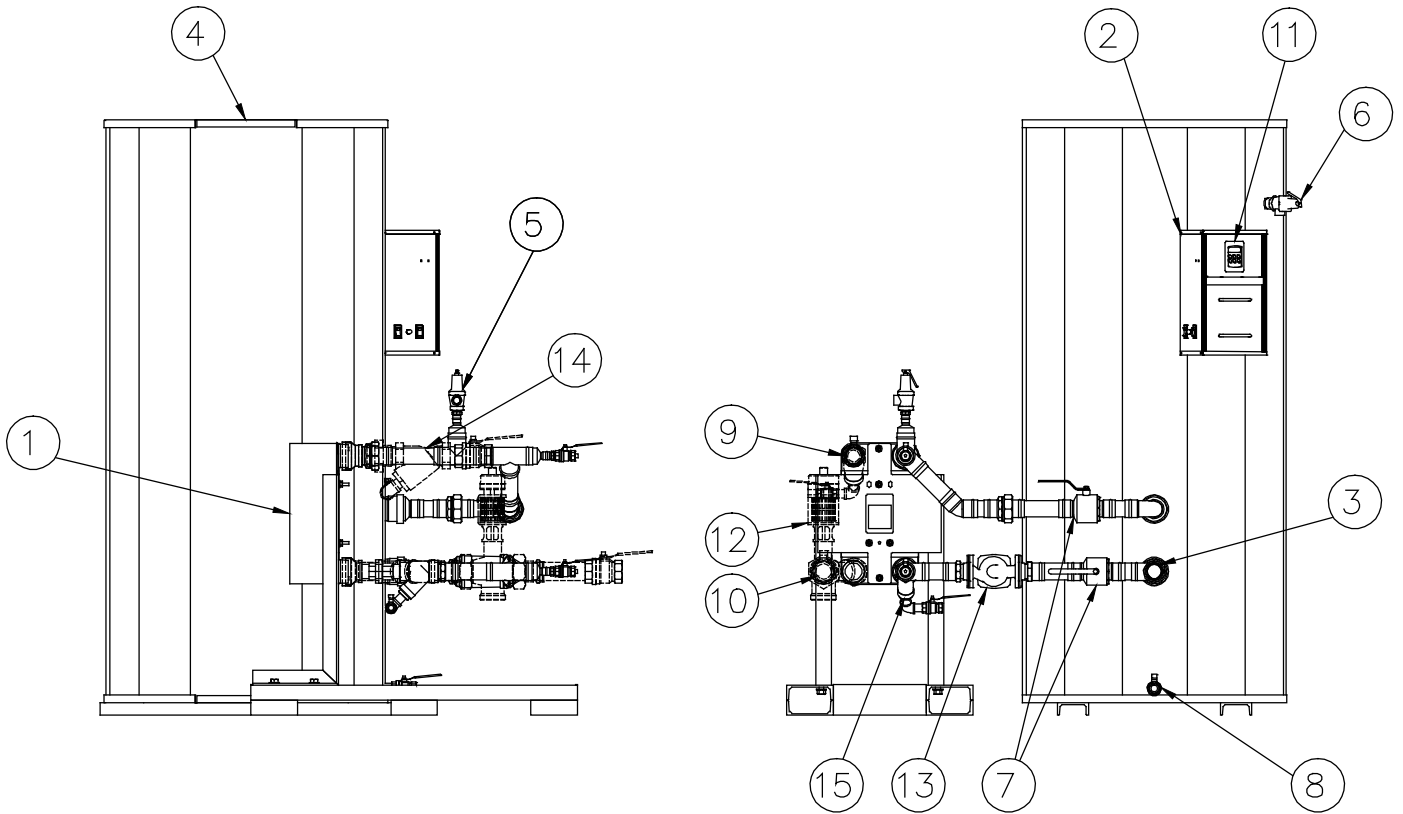

**Typical EZ Plate™ Storage Water Heater Construction**

- |   |   |
|---|---|
| 1. Heat Exchanger (Heat Engine)         | 9. Boiler Water Inlet   |
| 2. Control Enclosure                    | 10. Boiler Water Outlet   |
| 3. Potable Water Inlet                  | 11. Electronic Operating Control                                      |
| 4. Potable Water Outlet                 | 12. Boiler Water Control Valve (optional)                             |
| 5. Heat Exchanger Pressure Relief Valve | 13. Integral Circulation Pump   |
| 6. Tank T&P Relief Valve                | 14. Boiler Water Y-strainer<br>(Customer obtained from PVI or others) |
| 7. Isolation Shutoff Valves             | 15. Water Y-strainer  |
| 8. Tank Drain Valve                     |   |

**NOTE: Components, controls and connection locations may vary.**

# EZ Plate™ Storage Water Heater

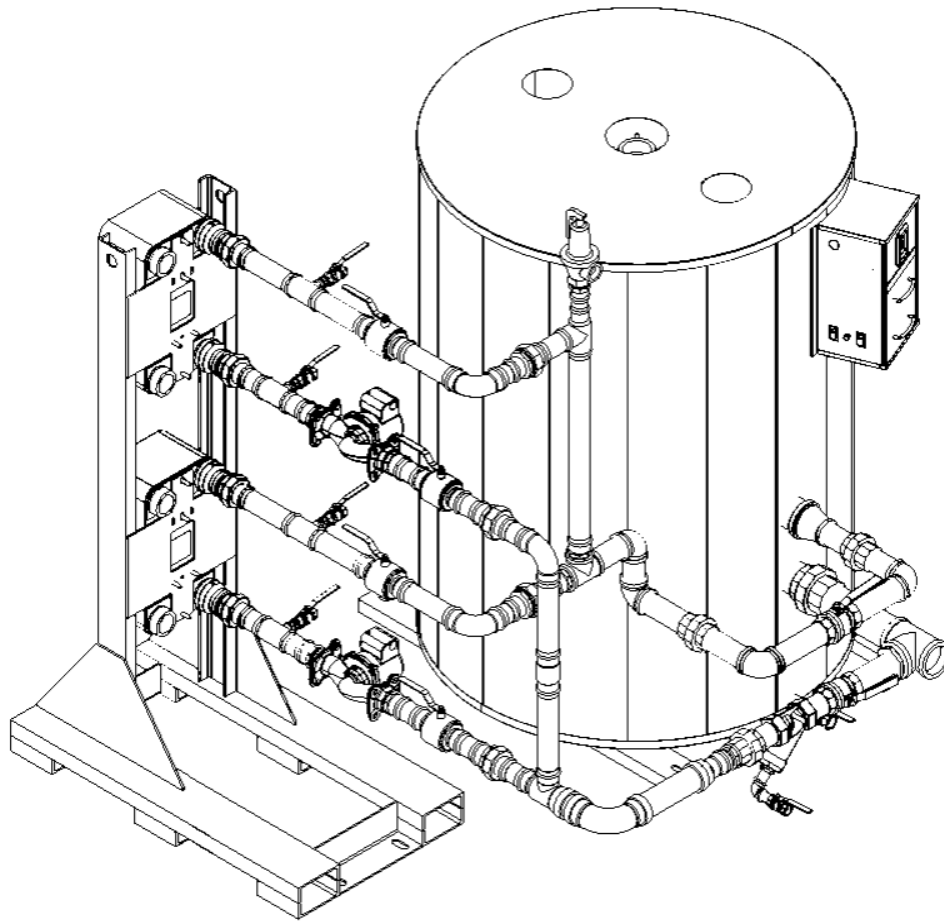

**Dual Heat Exchanger Models: Primary is lower; Secondary is upper.**

# EZ Plate™ Storage Water Heater

## 3 WATER HEATER INSTALLATION

### 3.1 Warranty

Factory warranty does not cover improper installation or operation. (See warranty for complete details).  
Warranty exclusions include but are not limited to failure or malfunctions resulting from:

1. Failures to properly apply, install, operate, or maintain the appliance in accordance with printed instructions.
2. Abuse, alteration, accident, fire, flood and the like.
3. Sediment or lime buildup, freezing or any other conduction causing inadequate circulation.
4. Corrosive or contaminated atmosphere.

### 3.2 Checking Equipment Before You Install

Inspect the unit completely upon receipt from the freight carrier before signing the bill of lading. Inspect the appliance and all accompanying parts for signs of impact or mishandling. Verify the total number of pieces shown on packing slips with those actually received. Contact the freight carrier immediately if any damage or shortage is detected.

### 3.3 Codes

The equipment must be installed in accordance with the instructions in this manual, appliance markings and supplemental instructions and in compliance with those installation regulations in force in the local area where the installation is to be made. These must be carefully followed in all cases. Authorities having jurisdiction must be consulted before installation is made. In the absence of such regulations, the installation must be in accordance with the instructions in this manual, appliance markings, supplemental instructions and in compliance with the latest edition of the applicable state and local mechanical and plumbing codes. The storage tank conforms to the current edition of the ASME Boiler and Pressure Vessel Code Section IV, Part HLW and the plate heat exchanger conforms to the current edition of the ASME Boiler and Pressure Vessel Code Section VIII.

### 3.4 Electrical Requirements

This appliance is wired for 120VAC/1ph/60Hz service, as standard (check decal on product). The appliance must be electrically grounded in accordance with the requirements of the authority having jurisdiction or in the absence of such requirements, with the latest edition of the National Electrical Code ANSI/NFPA No. 70. When the unit is installed in Canada, it must conform to the CAE C22.1, Canadian Electrical Code and/or Local Electrical Codes.

- Supply the electrical service specified on the water heater data decal to each water heater. Separate electrical circuits are recommended for multiple appliance installations.
- Branch circuit protection and a disconnecting means must be furnished by the installer. Refer to the provided wiring diagram when installing or troubleshooting electrical components of this appliance.
- All wiring between the water heater and field installed devices must be made with type T copper wire of proper size for the appliance load. Damage resulting from use of aluminum wiring is not covered by the product warranty.
- Line voltage wire exterior to the water heater must be enclosed in approved conduit or approved metal clad cable.
- Protect all water heater internal and external electrical components, wiring and electrical service connections from water (dripping, spraying, rain, etc.) at all times.

Utiliser du fil de cuivre de la taille appropriée pour le service électrique entrant. Les dommages résultant de l'utilisation de fil d'aluminium seront exclus du champ d'application de la garantie de cet appareil.

### 3.5 Handling and Locating the Water Heater

**WARNING: Use industry standard safe rigging methods, such as including the use straps and spreader bars and lifting from the water heater base skid assembly, when attempting to lift or move this product. Failure to follow industry standard safe rigging methods can cause uncontrolled tipping or dropping the water heater, resulting in property damage, personal injury or death.**

1. Do not attempt to move or lift the water heater by the plumbing connections or heat exchanger. Lift only by the skid using industry standard safe rigging methods.
2. Locate the water heater in a clean and dry area as close as possible to the greatest hot water usage and as near to boiler water and/or electrical power as practical.
3. Confirm that the system utilities are adequate to meet the water heater requirements on the information decal.
4. These water heaters are suitable for indoor installation only and must not be subject to freezing.
5. The water heater must be placed on a level surface. Installation on a 4 inch to 6 inch housekeeping pad is recommended.

# EZ Plate™ Storage Water Heater

6. Locate the water heater so that if water connections should leak, water damage will not occur. Water damage is not covered by the manufacturer's warranty.
7. Locate the water heater near a suitable drain capable of accepting hot water discharge (potentially in excess of 210°F) from the water heater temperature and pressure relief valve
8. Floor mounting provisions and tie down anchor points are provided. Pilot holes are indicated on the jacket for securing the equipment. Code requirements vary by geographical location, additional strapping or braces may be required. Please refer to your local codes for specific requirements.
9. Once the water heater storage tank and heat engine are placed in their final location, carefully remove all shipping supports and bracing.

## 3.6 Service Clearances and Clearance to Combustibles

**Service Clearance:** A minimum service clearance of 18" is recommended on all sides and above the appliance to facilitate easy access for inspection and service of installed components. Optional equipment may increase the clearance requirements.

Also allow sufficient space for installing and servicing connections such as building water, electrical, pump, boiler water and other auxiliary/optional equipment.

**Clearance to combustibles:** A minimum clearance to combustible materials of 6" is required.

Un dégagement minimal aux matériaux combustibles est de seize cm (16 cm) est nécessaire.

## 4 GENERAL PIPING GUIDELINES

### 4.1 Potable Water Inlet and Outlet Connections

**CAUTION:** To maintain tank corrosion resistance and warranty, do not contact inside (water side) of tank, nozzles or stainless steel fittings with ferrous (i.e. iron or steel) metal, tools, brushes, etc.

**IMPORTANT:** Do not use di-electric nipples, galvanized pipe or fittings or steel pipe or fittings when making waterside connections. Use only non-ferrous waterside materials.

1. All domestic and boiler water pipes should be flushed before assembly and installation. Failure to flush lines could cause components to clog or malfunction.
2. To avoid shipping damage, some piping assemblies may be disconnected and separately secured to the shipping container. Such assemblies must be reconnected. Align and re-connect the heat engine potable water lines to the storage tank as shown in the product description. If necessary, the storage tank and heat engine can be relocated by the customer using field-supplied piping. A larger field-supplied pump may be necessary when increasing the distance between the heat engine and the tank.
3. Always use a back-up wrench on tank and heat engine piping when tightening unions, valves, flanges, etc. Damage caused by plumbing mistakes, such as over-tightening or not using a backup wrench is not covered by warranty.
4. Piping and components connected to the water heater must be suitable for potable water, for the water temperatures they will experience and for their application.
5. Install shut-off valves and unions in the potable water and boiler water inlet and outlet piping to aid in servicing. Use caution when threading pipe nipples into tank and heat engine connections to prevent cross threading, or over-tightening.
6. Thermal Expansion Tank – If the water heater is installed in a closed water supply system, such as one having a back-flow preventer in the cold water line, provide thermal expansion control.
7. Pipe the Y-strainer blow-down valve and the storage tank drain valve to a suitable open drain capable of accepting hot water at the temperature discharged when opening the water heater drain valves.

## EZ Plate™ Storage Water Heater

8. When two or more water heaters are piped in parallel it is important that the piping systems are balanced to assure the full combined capacity is realized. Reverse return piping is recommended for multiple unit installations.
9. Do not use the water heater or attached piping as an electrical ground of any kind.
10. After plumbing, confirm all connections, components and fittings are leak free.
11. After checking for leaks, the heat exchanger and all boiler water and hot potable water piping must be insulated to the minimum pipe insulation thickness specified in ASHRAE 90.1, "Energy Standard for Buildings Except Low-Rise Residential buildings." Insulate or otherwise protect cold water supply lines if subject to freezing during operation or shutdown periods.

**WARNING: Insulate or guard all surfaces containing hot water. Uninsulated or unguarded surfaces containing hot water can be hot enough to cause severe burns instantly, if contacted. Failure to insulate or guard all surfaces containing hot water can result in property damage, personal injury, or death.**

Isoler ou protéger toutes les surfaces contenant de l'eau chaude.

### 4.2 Storage Tank Temperature and Pressure Relief Valve Piping

The EZ Plate water heater storage tank is supplied with temperature and pressure relief valve(s) sized in accordance with the ANSI/ASME Boiler and Pressure Vessel Code, Section IV. The relief valve(s) must be threaded directly into the dedicated relief valve fitting(s) located near the top of the storage tank and each relief valve discharge must be separately plumbed to an appropriate floor drain. The discharge line must not be smaller than the relief valve opening, must allow complete drainage of the valve and line and it must be positioned in the floor drain, such that water or steam forcefully exiting the drain line does not openly splash.

The water heater must not be operated without a correctly installed, properly sized and properly operating relief valve. If a replacement relief valve is required, it must be of the same type, temperature and pressure rating, and relieving capacity as the original relief valve supplied with the water heater.

Do not plug or restrict the relief valve or the relief valve drain line.

It is strongly recommended that the relief valve(s) should be manually operated at least once a year. If water does not freely flow from the manually operated relief valve or if it does not fully reseat when released, the relief valve must be replaced with a new relief valve meeting the same ratings.

**WARNING: Do not install a reducing coupling, valve or other restriction between the relief valve discharge and a suitable floor drain. Such restriction could prevent the valve from fully relieving if the pressure settings are exceeded, which could result in property damage, personal injury or death.**

**WARNING: Secure the relief valve piping to a suitable floor drain such that very hot water does not openly splash during a significant relief valve discharge. If the relief valve pipe is not routed and secured to a suitable drain, hot water discharge can result in property damage, scalding and personal injury or death.**

**IMPORTANT: Thermal Expansion** - A relief valve that periodically discharges may result from thermal expansion. If the water heater is installed in a system closed by components, such as a backflow preventer or check valve in the cold water supply, the system must be provided with means to control expansion. Contact a water heater or plumbing professional to resolve this situation.

### 4.3 Cathodic Protection

PVI water heaters do not utilize cathodic protection. However, in hot water systems containing other water heaters that utilize cathodic protection, hydrogen gas can be produced when the hot water system has not been used for a long period of time (generally two weeks or more). **Hydrogen gas is extremely flammable.** To prevent the possibility of injury under these conditions, one of the hot water system faucets should be opened for several minutes before using any electrical device connected to the hot water system. If hydrogen is present, there is frequently an unusual sound such as air escaping through the pipe as the hot water begins to flow. Do not smoke, have open flames or turn electrical switches on or off near the faucet at the time it is open.



# EZ Plate™ Storage Water Heater

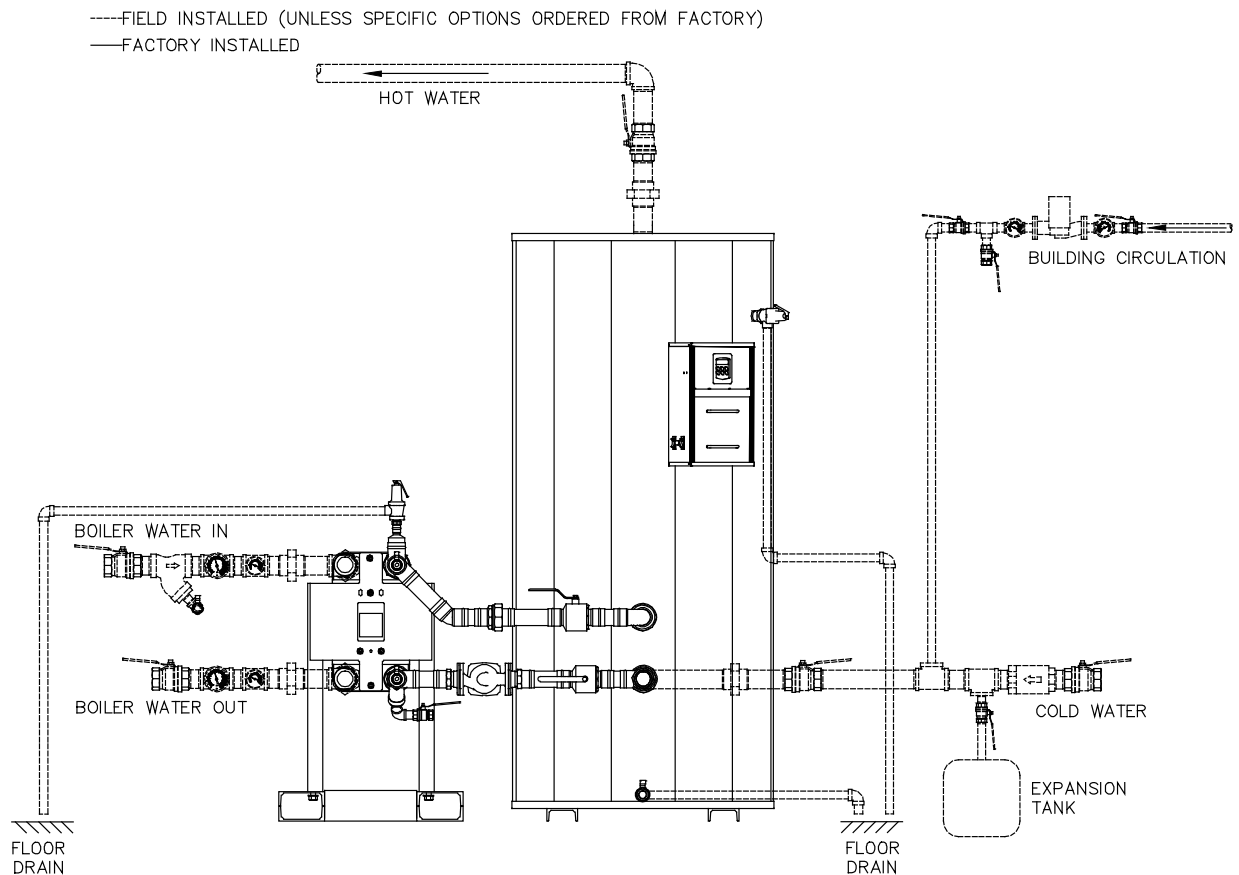

Typical EZ Plate™ Storage Piping Arrangement

## 4.4 Boiler Water Piping

**WARNING:** All system piping to the heat exchanger plumbing must be adequately supported. Failure to provide adequate support will result in excessive loads on the heat exchanger connections that can cause hot water discharge resulting in property damage, scalding and personal injury or death.

1. All boiler and domestic water pipes should be flushed before assembly and installation. Failure to flush lines could cause components to clog or malfunction.
2. This water heater will perform in accordance with the boiler water and domestic water temperatures and flows to which it is connected. To obtain the desired performance, it must be installed to operate with the temperature and flow conditions specified when selecting the appliance. The boiler water piping must be sized to deliver sufficient hot water to the heat exchanger without excessive pressure drop.
3. Always use a back-up wrench on tank and heat engine piping when tightening unions, valves, flanges, etc. Damage caused by plumbing mistakes, such as over-tightening, cross threading or other installation damage is not covered by warranty.
4. Install shut-off valves and unions in the boiler water and potable water inlet and outlet piping to aid in servicing. Use caution when threading pipe nipples into tank and heat engine connections to prevent cross threading, or over-tightening.
5. Obtain and install a Y-strainer, with a blow-down valve piped to a suitable drain, in the boiler supply piping near the heat exchanger inlet. If the water heater is equipped with the optional factory installed 2-way on/off control valve or 3-way diverting control valve, a factory installed Y-strainer and blow down valve is included and the blow-down valve must be piped to a suitable drain.
6. Confirm an air separator is installed the boiler supply piping to the heat exchanger.
7. If a boiler water control valve is installed, maintain standard design practice to avoid “deadheading.”
8. When two or more heaters are piped in parallel it is important that the piping systems are balanced to assure the full combined capacity is realized. Reverse return piping is recommended for multiple unit installations.
9. Do not use the water heater or attached piping as an electrical ground of any kind.

## EZ Plate™ Storage Water Heater

10. After plumbing, confirm all connections, components and fittings are leak free.
11. After checking for leaks, the heat exchanger and all boiler water and hot potable water piping must be insulated to the minimum pipe insulation thickness specified in ASHRAE 90.1, "Energy Standard for Buildings Except Low-Rise Residential buildings".

**WARNING: Insulate or guard all surfaces containing hot water. Uninsulated or unguarded surfaces containing hot water can be hot enough to cause severe burns instantly, if contacted. Failure to insulate or guard all surfaces containing hot water can result in property damage, personal injury, or death.**

Isoler ou protéger toutes les surfaces contenant de l'eau chaude.

### 4.5 Heat Exchanger Pressure Relief Valve Piping

The EZ Plate heat exchanger is supplied with a pressure relief valve sized in accordance with the ANSI/ASME Boiler and Pressure Vessel Code, Section VIII. The relief valve must be threaded directly into the dedicated relief valve fitting located near the top of the heat exchanger and each relief valve discharge must be separately plumbed to an appropriate floor drain. The discharge line must not be smaller than the relief valve opening, must allow complete drainage of the valve and line and it must be positioned in the floor drain, such that water or steam forcefully exiting the drain line does not openly splash.

The water heater must not be operated without a correctly installed, properly sized and properly operating relief valve. If a replacement relief valve is required, it must be of the same type, pressure rating, and relieving capacity as the original relief valve supplied with the water heater.

Do not plug or restrict the relief valve or the relief valve drain line.

It is strongly recommended that the relief valve(s) should be manually operated at least once a year. If water does not freely flow from the manually operated relief valve or if it does not fully reseat when released, the relief valve must be replaced with a new relief valve with the same ratings.

**WARNING: Do not install a reducing coupling, valve or other restriction between the relief valve discharge and a suitable floor drain. Such restriction could prevent the valve from fully relieving if the pressure settings are exceeded, which could result in property damage, personal injury or death.**

**WARNING: Secure the relief valve piping to a suitable floor drain such that very hot water does not openly splash during a significant relief valve discharge. If the relief valve pipe is not routed and secured to a suitable drain, hot water discharge can result in property damage, scalding and personal injury or death.**

# EZ Plate™ Storage Water Heater

## 4.6 Connecting Pump(s) and Valves (if equipped)

**WARNING:** Turn off all electrical service to the appliance before accessing electrical components or terminals located inside the control cabinet, junction boxes or at other points of wiring access. These terminals and components may be high voltage. Close and fasten the control cabinet cover, junction boxes and all other points of wiring access before restoring electrical service to the appliance. If the electrical service is not turned off and these components or terminals are touched, a dangerous shock can occur, which can result in property damage, personal injury or death.

Coupez l'alimentation avant intervention sur l'appareil.

After turning off all power to the water heater, connect and tighten the supplied 1/2" flexible conduit and wires from the Heat Engine to the bottom fitting of the control panel attached to the storage tank. Then remove the wire nuts from the wires grouped near the bottom inside the control panel and use those wire nuts to attach them to the same color wires coming from the Heat Engine conduit. The following schematic is representative of how to make the matching color connections, but the wire colors and number connections may vary.

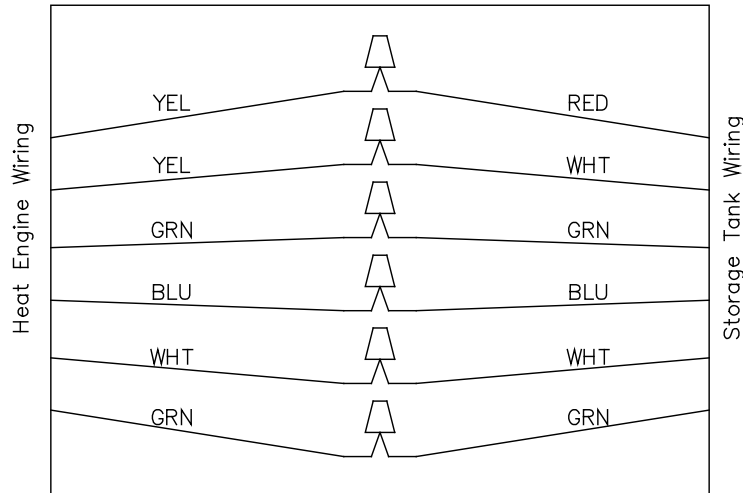

## 4.7 Filling the Unit

1. Fill the system with water. To be sure that the unit is not "air bound," open the relief valve. Leave the valve open until a steady flow of water is observed. Close valve and complete filling the system.
2. Make sure there are no system leaks. DO NOT use petroleum based stop-leak products. All system leaks must be repaired.

# EZ Plate™ Storage Water Heater

## 5 OPERATING AND SAFETY CONTROLS

**WARNING:** Turn off all electrical service to the appliance before accessing electrical components or terminals located inside the control cabinet, junction boxes or at other points of wiring access. These terminals and components may be high voltage. Close and fasten the control cabinet cover, junction boxes and all other points of wiring access before restoring electrical service to the appliance. If the electrical service is not turned off and these components or terminals are touched, a dangerous shock can occur, which can result in property damage, personal injury or death.

Coupez l'alimentation avant intervention sur l'appareil.

### 5.1 High Water Temperature Limit Control

The appliance is equipped with an adjustable temperature limit control and a non-adjustable high temperature limit control. These controls are located inside the control cabinet and are accessed by removing the bottom cover.

The adjustable limit control is an auto reset type and should be adjusted at least 10 degrees above the set point of the Operating Thermostat.

The high limit is an auto reset type with a fixed set point, but is optionally available as a manual reset type. If the high limit is a manual reset type, it cannot be reset until the water temperature has dropped below its reset point.

### 5.2 Electronic Low Water Cut-Off (Optional)

The optional low water cut-off remains energized and allows the water heater to operate as long as the water level is above the electrode position in the storage tank. When the water level falls below the electrode position for more than three seconds, the low water cut-off de-energizes and turns off the pump, which stops heat from being added to the storage tank.

# EZ Plate™ Storage Water Heater

## 6 TEMPTRAC™ ELECTRONIC CONTROLLER PANEL

### 6.1 Principle of Operation

The water heater operates to satisfy the setpoint of the TempTrac digital control whose sensor is located near the energy source of the water heater tank. Demand (flow) will typically create a drop in temperature, thus activating the water heater to add heat to the stored water. This setpoint is the desired water temperature to maintain.

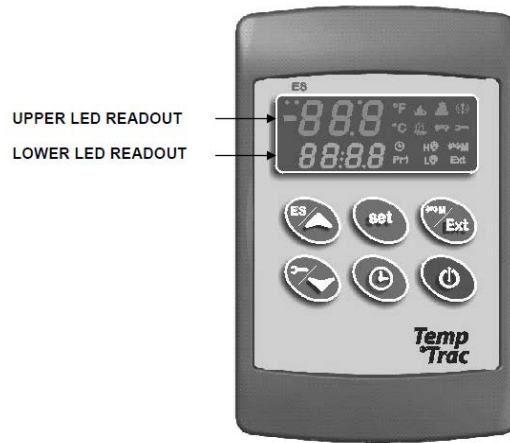

### 6.2 Upper LED Readout

The default display of the upper readout (Probe 2) is the water temperature near the hot water outlet.

This readout can display additional information by pushing the EXT button to cycle through the following items:

- The modulation rate of the valve, if applicable, indicated by 0 to 100%.
- The temperature difference between Probe 1 and Probe 2.
- All of the display information described above is available for monitoring through the optional MODBUS RTU interface.

### 6.3 Lower LED Readout

The default display of the lower readout (Probe 1) is the water temperature sensed near the middle of the water heater tank. This sensing location serves as the primary control temperature for the TempTrac.

### 6.4 Control Buttons

<b>SET</b>	Displays and modifies the temperature set points. In programming mode, it selects a parameter or confirms an operation.
<b>UP</b>	Displays and modifies the energy saving (Night Time setback) settings. In programming mode, it browses the parameter codes or increases a displayed value.
<b>DOWN</b>	Displays the working hours of the load relays. In programming mode, it browses the parameter codes or decreases a displayed value.
<b>CLOCK</b>	Changes lower display from the stored water temperature to current time and day.
<b>EXT</b>	Changes upper display from Probe 1 temperature to Probe 3 temperature, displays the temperature difference of the stored water temperature minus Probe 2 temperature and firing rate of the burner from 0 to 100%. In programming mode it sets the 4-20mA output (password is required).
<b>ON/OFF</b>	Switches the control ON or OFF.















(See TempTrac User Manual PV500-41 for full description)

# EZ Plate™ Storage Water Heater

## 6.5 Key Combinations

- Use the **UP + DOWN** key to lock and unlock the keyboard.
- Use the **SET + DOWN** arrow to enter the programming mode.
- Use the **SET + UP** arrow to exit the programming mode.

## 6.6 LED Icon Legend

LED	MODE	Function
°F	ON	Temperatures are displayed in degrees Fahrenheit
°C	ON	Temperatures are displayed in degrees Celsius
	Flashing	Call for heat time delay or remote enable/disable is in standby (disabled)
	ON	Call for heat is on
	Flashing	Second stage time delay ( <i>On 2-stage units only</i> )
	ON	Second stage on or the <b>AL2</b> alarm output is enabled.
	Flashing	Output 3 time delay
	ON	Output 3 relay on
	ON	Modulation output signal is in manual control mode or forced to the <b>i1S</b> setting by digital input 1
	ON	Modulation output signal is automatically controlled by temperature probe 1
	Flashing	Modulation output time delay is activated.
Ext	ON	Probe 3 is displayed
	FLASHING	Digital input 2 (alarm) is activated
	FLASHING	Digital input 3 (alarm) is activated
	ON	Lower display is displaying the time
	FLASHING	Alarm signal
	FLASHING	Programmed working hours limit is exceeded
	ON	Working hours are displayed in Lower LED readout
ES	ON	The energy saving function is running

## 6.7 To View the Setpoint

- Push and release the **SET** key to see the set point value.
- To return to normal display, press **SET + UP** or wait 15 seconds without pressing any key.

## 6.8 To Change the Setpoint

- Push the **SET** key. The upper display will show the “St1” parameter name, while the lower display will show its value.
- Use the **UP** or **DOWN** key to cycle through the parameter names.
- Push the **SET** key to modify a parameter value. The value starts flashing in the lower display.
- To change it push the **UP** or **DOWN** keys. Push the **SET** key again to confirm the value and pass to the setting of next set point.
- Repeat the operations described at points 3, 4, 5.
- **To Exit:** press **SET + UP** or wait 15 seconds without pressing any key.

**NOTE:** Each point has a time out of 15 seconds. If any key is pushed within 15 seconds the controller exits the set points programming procedure.

**NOTE:** The set value is stored even when the procedure is exited by waiting the time-out to expire.

# EZ Plate™ Storage Water Heater

## 6.9 To Set the Current Time and Day (Military Time)

- Push and hold the **CLOCK** key for more than 3 seconds. The LED icon starts flashing and the “**Hur**” (hour) parameter name is displayed in the Upper LED readout, its value is displayed in the Lower LED readout.
- Pushing the **UP** or **DOWN** key alternates the LED readouts between the following:
  - “**Hur**” (hour) in the Upper readout and its value in the lower readout
  - “**Min**” (minute) in the Upper readout, its value in the Lower readout
  - “**dAY**” (day) in the Upper readout, its value in the Lower readout
- To adjust a value, press the **SET** key and the value in the Lower LED will start flashing. Change the value by pressing the **UP** or **DOWN** keys. When correct, press the **SET** key.
- To exit push **SET + UP** keys or wait 15 seconds without pressing any keys.

**NOTE:** This device recognizes Sunday as the first day of the week and Saturday as the last.

## 6.10 To Set the Energy Saving Time (Nighttime Setback)

- Push and hold the **UP** key for more than 3 seconds and the first parameter of the energy saving will be displayed.
- Use the **UP** or **DOWN** keys to browse them.
- To change a value, push the **SET** key followed by **UP** or **DOWN** and then the **SET** key again.
- To exit from the menu, press **SET** and **UP** or wait for 30 seconds.

## 6.11 To Set Modulation Parameters

- Push and hold the **EXIT** key for more than 3 seconds and the LED will switch **ON** and a passkey will be required to view and manually change the modulation % value. Passkey is “321”.
- Upon entering the password, the modulation % value will be displayed in the lower display.
- To manually adjust this value, push the **SET** key; the value will start flashing. Adjust it by using the **UP** or **DOWN** keys and then the **SET** key again.
- To exit from the menu, press **SET** and **UP** keys together or wait for 30 seconds.



## 6.12 To Change Other Parameters

- Push the **SET** and **DOWN** arrow simultaneously for 3 seconds.
- Select the required parameter. The name of the parameter is on the upper display; its value is on the lower display.
- Press the **SET** key: the value of the parameter will start blinking.
- Use **UP** or **DOWN** to change the value.
- Press **SET** to store the new value and move to the following parameter.
- **To Exit:** Press **SET + UP** or wait 15s without pressing a key.

# EZ Plate™ Storage Water Heater

## 6.13 LED Display Alarm Messages

Alarm messages are displayed in the upper LED readout and alternate with the default display. An alarm LED ICON is also illuminated.

ALARM MESSAGE	CAUSE	RESULTS OF ALARM CONDITION	RECOMMENDED ACTION
"P1"	TP1 probe failure	Inlet temperature sensor is not connected or is reading incorrectly. Call for heat and burner modulation output signal will revert to low fire.	Check wiring and sensor Terminals 14 & 17
"P2"	TP2 probe failure	Temperature sensor is not connected or is reading incorrectly.	Check wiring and sensor Terminals 15 & 17
"P3"	TP3 probe failure	Temperature sensor is not connected or is reading incorrectly or flue gas temperature protection is disabled.	Check wiring and sensor Terminals 16 & 17
"HA"	High temperature limit setpoint exceeded	Audible alarm sounds, operation continues.	Manual reset required
"LA"	Low temperature alarm	Audible alarm sounds, operation continues.	
AL1	Digital input 1 is activated.	Unit de-energized after timer delay. Audible alarm sounds.	Manually reset required
AL2	Digital input 2 is activated. This alarm indication is dedicated to the Alarm On Any Failure feature of this product.	Unit de-energized after timer delay. Audible alarm sounds. Alarm contacts close for remote indication of alarm. Internal alarm register will communicate an alarm condition through the Modbus RTU communication link.	Manually reset required
AL3	Digital input 3 is activated.	Unit de-energized after timer delay. Audible alarm sounds.	
Mn1	Maintenance alarm for output 1	Buzzer sounds, operation continues	Check wiring and sensor
Mn2	Maintenance alarm for output 2	Buzzer sounds, operation continues	Check wiring and sensor
Mn3	Maintenance alarm for output 3	Buzzer sounds, operation continues	Check wiring and sensor
"rtc"	The real time clock has lost its setting	Energy saving function disabled	Reprogram clock
CONTROL MESSAGE	CAUSE	RESULTS OF CONTROL CONDITION	NOTES
 On	A call-for-heat condition	The burner operating sequence should begin.	If the burner does not operate, check safety devices or Remote Proving Interlock
 Flashing	The remote enable/disable has been triggered	The small flame icon will flash indicating the standby state	The R1-R2 terminals have been opened by the remote master control. The heater will remain in standby.
	Integral circulation pump	The integral circulation pump will operate until the water temperature has equalized	Pump may operate before, during or after the call-for-heat



# EZ Plate™ Storage Water Heater

## 6.14 Audible Alarm

The TempTrac audible alarm is activated each time a connected alarm condition occurs. The following are representative alarm conditions that may be connected to and activate the TempTrac audible alarm (some alarms may be connected to and operate separately from the TempTrac on some products).

- High/low water temperature alarm
- Probe failures
- External thermostat limit failure
- Low water

The audible alarm is silenced by pressing any button (alarm condition still present).

## 6.15 Alarm Recovery

- Probe failure alarm automatically ends after normal operation is re-established. Check connections before replacing the probe.
- Temperature alarms “**HA**” and “**LA**” automatically stop as soon as probe 1 senses temperatures within normal operating parameters.
- Digital input 2 & 3 alarms recover when condition(s) listed above are normalized and any button is pressed (if used). Resetting the alarm condition may require resetting individual safety devices or cycling main power switch.
- RTC alarm stops after programming the real time clock.
- RTF alarm requires the replacement of the real time clock.

**For additional information, contact the PVI Industries Customer Service Dept at 800-433-5654.**

# EZ Plate™ Storage Water Heater

## 7 DESCRIPTION OF OPERATION

The EZ PLATE storage water heater can provide potable water up to 175°F, using boiler water as the energy source. The supplied boiler water temperature must be within the range of 125°F to a maximum of 180°F and must be at least 5°F above the potable water temperature desired from the water heater storage tank outlet.

The water heater storage tank and heat engine (heat exchanger and associated components) are assembled on separate skids then, factory plumbed together in the typical side by side configuration. If necessary, the storage tank and heat engine can be relocated by the customer using field-supplied piping. A larger field-supplied pump may be necessary when increasing the distance between the heat engine and the tank.

### 7.1 Sequence of Operation

1. When there is demand for hot water consumption, hot water exits from the top of the storage tank and is replaced by cold water entering the bottom of the tank. When enough cold water enters the storage tank to lower the stored hot water temperature below the set-point entered into the programmable electronic operating control thermostat, the control circuit closes creating a call-for-heat, which energizes the circulating pump (and boiler water control valve, if supplied).
2. When the circulating pump is energized (and boiler water control valve, if supplied), the pump circulates domestic water from the storage tank through one side of the heat exchanger plates. Boiler water flowing on the other side of the heat exchanger plate heats the domestic water before it returns to the storage tank.
3. When the stored water temperature increases above the set-point entered into the programmable electronic operating control thermostat, the control circuit opens and the circulating pump (and boiler water control valve, if supplied) is de-energized.
4. When the circulating pump is de-energized, the pump stops running and no more heated water flows from the heat exchanger to the storage tank.
5. If, for any reason, the water temperature in the storage tank raises above the set-point entered into the programmable electronic operating control thermostat, the circulating pump (and boiler water control valve, if supplied) will be de-energized by the adjustable limit control or the fixed high limit.

### 7.2 Dual Heat Exchanger Models

The Dual Heat Exchanger EZ Plate Storage will operate as primary and secondary heat engines. The primary heat engine will follow the sequence of operation as described above. The secondary heat engine will also follow the same sequence of operation, except with a temperature offset (St2 in TempTrac control) from the primary. The offset will be factory set at 0°. This can be changed for staging the heat engines if desired. (Recommended starting point for staging is -5°.)

# EZ Plate™ Storage Water Heater

## 8 START-UP AND SHUTDOWN PROCEDURE

1. When placing the unit into operation, open relief valve to purge air from top of tank and begin to fill the tank with cold water. Check for plumbing leaks. Be sure the tank is completely filled before closing the relief valve.

**CAUTION:** To avoid pump damage, do not energize the heater or circulating pump until the tank is full of water.

2. Push control switch, located on the control box, to “ON” to activate the pump and thermostats. On Dual Heat Exchanger models, also push the pump switch for the heat exchanger being started. Check the pump for operation; the pump motor should run when operating switch is pushed “ON”. Check operating thermostat settings.

The operating thermostat is set at the factory at approximately 120°F. The temperature limiting device is factory set at approximately 200°F.

**CAUTION:** To avoid damage to the heat exchanger, gradually introduce boiler water to the heat exchanger.

3. Push the operating switch to “OFF” before opening manual main boiler water supply valve. To prevent thermal shock, do not admit boiler water to the heat exchanger suddenly when it is empty or cold. Gradually open boiler water supply valve until all passages of the heat exchanger are filled and slowly bring the heat exchanger up to temperature.

**WARNING: Do not operate heat exchanger under conditions in excess of those specified on nameplate and ASME data plate. Failure to operate the heat exchanger within the specified design pressure and temperature can cause damage to the heat exchanger resulting in property damage, personal injury or death.**

4. Push the operating switch to “ON” to energize the pump (and boiler water control valve, if supplied) and to begin heating the water in the storage tank. Allow the water temperature in the storage tank to rise above the set-point entered into the programmable electronic operating control thermostat and to de-energize the circulating pump (and boiler water control valve, if supplied).
5. Then, open a nearby hot water tap(s) to consume hot water from the tank, with is replaced with cold makeup water, lowering the stored water temperature. Confirm the pump cycles on when the stored water temperature drops enough to cause the programmable electronic operating thermostat to re-energize the circulating pump. Close the hot water tap(s) and again allow the stored water temperature to rise and the pump turn off. Repeat as necessary and check operation of all safety and operating controls.
6. Confirm there is no pulsation or water hammer, since this can cause vibration and strain which can result in damage or leaks. Contact a water heater or plumbing professional to resolve this situation.
7. Follow the supplemental instructions provided by the heat exchanger manufacturer to retighten the gasket joints after the heat exchanger has reached temperature to prevent leaks and gasket failures.
8. On Dual Heat Exchanger models, repeat steps 2 through 7 above for the secondary heat exchanger.
9. To shut the water heater down, remove all power from the system and close all boiler water and cold water supply valves to the unit. If the water heater is removed from service for an extended period of time, the storage tank, heat exchanger and piping must also be drained completely, to reduce the risk of damage by freezing, biologic growth or by corrosion from stagnant water conditions.

# EZ Plate™ Storage Water Heater

## 9 MAINTENANCE

**WARNING:** Turn off all electrical service to the appliance before accessing electrical components or terminals located inside the control cabinet, junction boxes or at other points of wiring access. These terminals and components may be high voltage. Close and fasten the control cabinet cover, junction boxes and all other points of wiring access before restoring electrical service to the appliance. If the electrical service is not turned off and these components or terminals are touched, a dangerous shock can occur, which can result in property damage, personal injury or death.

Coupez l'alimentation avant intervention sur l'appareil.

### 9.1 Temperature and Pressure Relief Valve

Manually test-operate the temperature and pressure relief valve(s) (T&P) on the storage tank and the pressure relief valve (PRV) on the heat exchanger at least once a year by briefly lifting the relief valve lever. If a relief valve does not open and close properly when test-operated, it must be replaced with a new relief valve of the same type, rating and relieving capacity as the original equipment relief valve it is replacing. See the sections titled "Storage Tank Relief Valve Piping" and "Heat Exchanger Relief Valve Piping" for important instructions and warnings.

### 9.2 Thermostats and Temperature Limiting Device

The temperature limiting device and thermostat temperature sensors extend into the water in the tank. Depending on the water conditions in your area, scale may coat the sensors. This coating will affect accuracy of sensors and can allow water temperature to exceed the desired limits. Remove and inspect these controls at necessary intervals and remove scale if present.

### 9.3 Control Valve Actuator (if supplied)

The boiler water control valve actuator is sealed and requires no maintenance. Durability of valve stems and packing is dependent upon maintaining non-damaging water conditions. Inadequate water treatment or filtration can result in corrosion, scale, and abrasive particle formation. Scale and particulates can result in stem and packing scratches and can adversely affect packing life and other parts of the hydronic system. Contact the manufacturer for replacement packing and stem & plug assembly.

### 9.4 Tank

Depending on water quality and operating temperature, scale can form during operation and will accumulate on the bottom of the tank. Inspect the tank every six months or more frequently if higher scaling conditions are present. To help prevent the accumulation of scale, flush the tank at the appropriate interval, based on water conditions in your location. **To flush:** turn off the electrical disconnect switch to remove power and to prevent the unit from operating. Open the drain valve and allow water to flow through the tank until it runs clear. Close the drain valve and turn on the electrical disconnect switch to restore power.

**NOTICE:** Since PVI cannot control the use of the appliance, water conditions, or maintenance, the warranty on the appliance does not cover poor performance, structural failure, or leaking due to an excessive accumulation of scale.

- a. If the unit requires shut down, remove all power from the system and close all boiler water and cold water supply valves to the unit. If the water heater is removed from service for an extended period of time, the storage tank, heat exchanger and piping must also be drained completely, to reduce the risk of damage by freezing, biologic growth or by corrosion from stagnant water conditions.
- b. When the appliance is returned to service, conduct a thorough inspection of all utilities and general appliance condition.

# EZ Plate™ Storage Water Heater

## 9.5 Heat Exchanger

Lime and scale deposited in the heat exchanger will result in an increase in pressure drop, lower temperature difference on the domestic water side or a high exit temperature on the boiler water side. Cleaning and flushing can be done without removing the heat exchanger from the system. There are threaded cleaning ports near the hot water outlet and cold water inlet of the heat exchanger.

The frequency of cleaning (descaling/deliming) will be determined by the rate of scale buildup. Until the appropriate cleaning interval is established, it is recommended that the heat exchanger be internally cleaned every six months or more frequently if higher scaling conditions become apparent. Factors that may affect the rate of scale buildup are the amount of hot water used and the temperature of the water. The more hot water used, the more fresh water containing scale-forming compounds is brought into the heat exchanger. As the temperature of water increases, the rate of scale deposition will increase.

The heat exchanger is provided with isolation shutoff valves to allow for quick isolation of the heat exchanger from the system, and clean-in-place (CIP) fittings for chemical descaling without removing the heat exchanger from the plumbing system. Close the isolation valves to the tank and cold water/recirculation inlet. With the heat exchanger properly cooled and depressurized, remove the plugs from the CIP fittings.

The Dual Heat Exchanger models are provided with isolation shutoff valves and pump shutoff switches to allow for quick isolation of individual heat exchangers without shutting down the entire system.

The heat exchanger is cleaned by flushing with a suitable food grade acid detergent or biodegradable descaler, available at most plumbing supply outlets:

- Isolate the heat exchanger from the hot boiler water and close the tank water isolation valves located near the heat exchanger domestic water inlet and outlet. Allow the heat exchanger to cool before cleaning.
- Prepare a 50% dilution of a commercial descaler in open container.
- Place a submersible utility pump into the descaler solution.
- Connect a hose from the pump to the lower cleaning port.
- Connect a second hose from the upper cleaning port to the descaler solution.
- Circulate through the heat exchanger and check the effectiveness of the solution visually and pH test.
- Flush system after cleaning.
- Remove all hoses from the CIP fittings, close the valves and replace the plugs.
- Open the tank water isolation valves located near the heat exchanger domestic water inlet and outlet.
- Follow the section titled “Start-Up and Shut-Down Procedure” to properly bring the water heater back online.

After cleaning the heat exchanger, clean the Y-strainer in the domestic water pipe near the circulator pump.

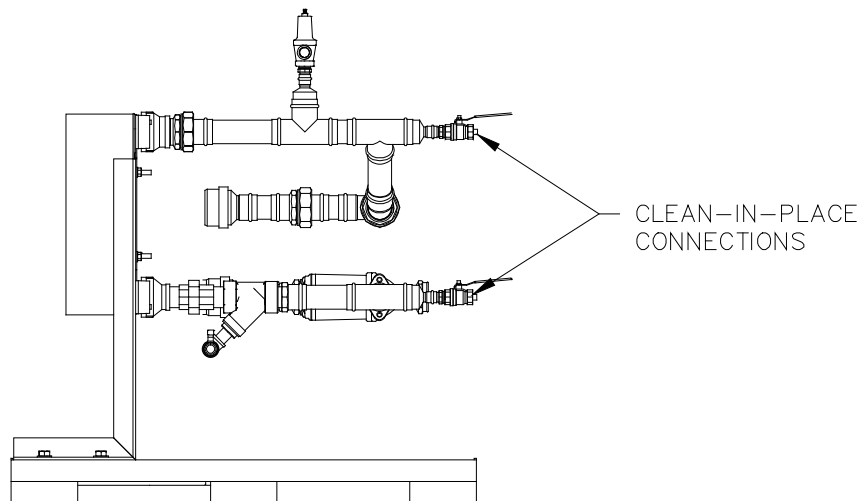

**Heat Exchanger Clean-In-Place Fittings**

# EZ Plate™ Storage Water Heater

## 9.6 Optional Boiler Water Valve Package (150 psig, 220°F maximum)

If the water heater is not utilized as the constant flow bypass in a VFD-equipped boiler loop and boiler flow is to be allowed only during a domestic water call for heat, the plate heat exchanger can be equipped with a motorized 2-way valve. In this configuration, the boiler water 2-way valve and the circulator are controlled by the TempTrac operator.

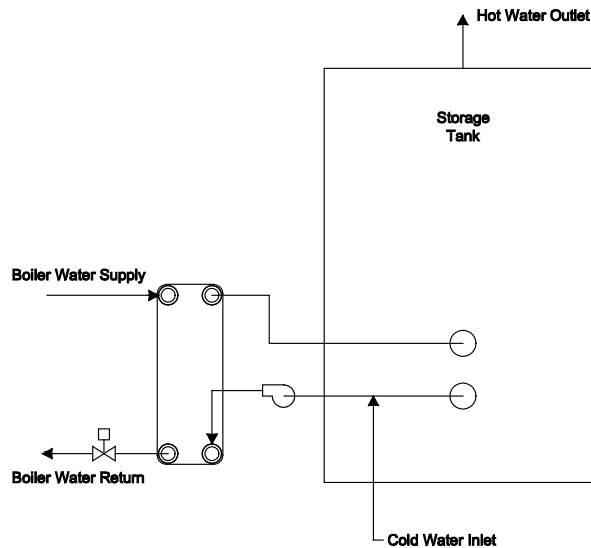

### 2-Way Boiler Water Control Valve

**IMPORTANT:** Protect the actuator from dripping water, condensation and other moisture. Water or moisture could result in an electrical short, which may damage or affect the operation of the actuator.

**IMPORTANT:** Do not cover the actuator with thermal insulating material. High ambient temperatures may damage the actuator, and a hot water pipe, steam pipe or other heat source may overheat it.

## 9.7 Recommended Maintenance Schedule

### 1. Annual Maintenance

- Check all joints, pipe connections and the heat exchanger for tightness, corrosion or deterioration.
- Check all pumps, valves, controls and devices including thermostats for proper operation.
- Check relief valves for proper operation.
- Test high limit and operating temperature controls.

### 2. Semi-Annually

- Recalibrate all indicating and recording gauges.
- Check piping and wiring of all interlocks and shutoff valves.

### 3. Monthly Maintenance

- Test low-water cutoff device (if equipped).
- Check gauges, monitors, and indicators.
- Check instrument and equipment settings.

### 4. As Required

- Tank flush and cleanout.
- Clean heat exchanger.
- Clean domestic water Y-strainer near circulator pump.
- Blow down or clean boiler water Y-strainer.

# EZ Plate™ Storage Water Heater

## 10 TROUBLESHOOTING NOTES

### Problem 1: Outlet water temperature not constant

- a. **Cause:** Insufficient recovery.  
**Solution:** Check and be sure heater design rating is not being exceeded.
- b. **Cause:** Malfunctioning or misadjusted thermostat(s).  
**Solution:** If the thermostat or controller is always open, then the outlet temperature will vary with load. Measure the tank temperature near the thermostat and compare to setpoint. The thermostat should turn on and off within approximately 5°F of setpoint, unless user or service technician has adjusted to a larger or smaller differential. Check wiring and replace if necessary.

### Problem 2: Heater recovery is slow or outlet temperature is below setpoint:

- a. **Cause:** The domestic water circulator pump is not operating properly.  
**Solution:** Check for proper operation of circulator pump. Replace if necessary.
- b. **Cause:** Y-Strainer in domestic water line near the recirculation pump or in the boiler water supply line to the heat exchanger is partially clogged.  
**Solution:** Blow down or clean boiler water and potable water Y-Strainers.
- c. **Cause:** Boiler water control valve is not fully opening.  
**Solution:** Check for proper operation of boiler water control valve and service if necessary.
- d. **Cause:** Heat exchanger is fouled.  
**Solution:** Inspect the heat exchanger for excessive scaling or fouling on the water side and clean if needed.
- e. **Cause:** Abnormal operating conditions.  
**Solution:** The water temperature has a significant effect on the efficiency of the heat exchanger. Check if the setpoint is higher than specified. Confirm the measured flow rate with meters or by volume and rate. Check that there are no other loads on the heater. Check if the boiler water to the heat exchanger is hot enough and that the required flow is maintained.

### Problem 3: No hot water even at low flow:

- a. **Cause:** Boiler water control valve not opening.  
**Solution:** Check that electrical coils are energized. If not, trace wiring problem. If so, the valve may be faulty, or the linkage (if applicable) is out of adjustment.
- b. **Cause:** The domestic water circulator pump is not operating.  
**Solution:** Check that electrical power is being provided to the circulator pump during a call for heat. If so, replace the pump. If not, trace wiring problem.
- c. **Cause:** Malfunctioning or misadjusted thermostat(s).  
**Solution:** Adjust thermostat to energize domestic circulator pump (and boiler water control valve, if supplied) at the desired water temperature. If the thermostat is properly adjusted and is not energizing the domestic circulator pump, verify wiring and replace the thermostatic control if necessary.
- d. **Cause:** The adjustable or fixed high-temperature limit is open.  
**Solution:** Check the individual components of the system and repair or replace the failed component(s) as necessary.

### Problem 4: Outlet temperature is too high and above setpoint:

- a. **Cause:** Malfunctioning or misadjusted thermostat(s).  
**Solution:** Adjust thermostat to de-energize domestic circulator pump (and boiler water control valve, if supplied) at the desired water temperature. If the thermostat is properly adjusted and is not de-energizing the domestic circulator pump, verify wiring and replace the thermostatic control if necessary.
- b. **Cause:** The pump is not deactivating.  
**Solution:** Relay in the system is malfunctioning. Replace defective components as required.

## EZ Plate™ Storage Water Heater

### Problem 5: Heat exchanger visibly leaking.

- a. **Cause:** Plumbing connection loose.  
**Solution:** Check and tighten plumbing connection.
- b. **Cause:** Brazed Plate heat exchanger leak.  
**Solution:** Once the leak is confirmed to be coming from the heat exchanger, isolate the heat exchanger and replace.
- c. **Cause:** Plate and frame heat exchanger leak.  
**Solution:** If one or more heat exchanger plate walls are breached, a double-wall heat exchanger will leak at the joint between the plates. Isolate the heat exchanger and replace one more plates to resolve leak.



# EZ Plate™ Storage Water Heater

---

Since PVI cannot control the use of the appliance, water conditions, or maintenance, the warranty on the EZ Plate Water Heater does not cover poor performance, structural failure, or leaking due to an excessive accumulation of scale.

---

---

MODEL NUMBER: \_\_\_\_\_

SERIAL NUMBER: \_\_\_\_\_

INSTALLATION DATE: \_\_\_\_\_

PVI Industries, LLC • 3209 Galvez Ave. • Fort Worth, TX 76111 • 1-800-433-5654 • [www.pvi.com](http://www.pvi.com)